

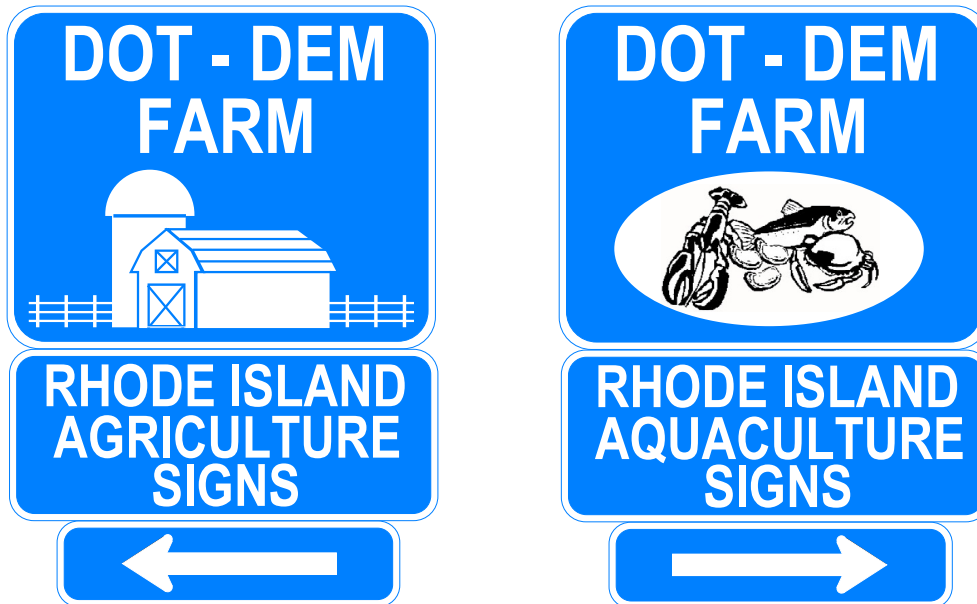

RHODE ISLAND DEPARTMENT OF TRANSPORTATION
RHODE ISLAND DEPARTMENT OF ENVIRONMENTAL MANAGEMENT
AGRICULTURE /AQUACULTURE SIGN PROGRAM



The Rhode Island Department of Transportation (R.I.D.O.T.) in conjunction with the Rhode Island Department of Environmental Management (R.I.D.E.M.) and the Rhode Island Farm Bureau is issuing the following regulations and standards for farm signs farm on state roads. Farm signs are intended for use on rural roads and shall not be used on interstate highways, freeways or interchanges.

All signs must meet the guidelines and standards as described on the following pages . Sign requests must be approved by R.I.D.E.M., with final approval by R.I.D.O.T. A sign request will be denied when the installation would obstruct a drivers vision or sight distance, obstruct mandatory highway signs or in any way may cause harm to vehicle or pedestrian traffic.

At any time the signs or business do not meet the regulations or standards of the Farm Sign Program, the signs will be removed by R.I.D.O.T. without prior notification.

Once the application is approved R.I.D.O.T. mark the locations for the signs. It is then responsibility of the farm owner to contact Dig Safe at 1-800-344-7233, prior to installing any signs.

For further information regarding the Agriculture /Aquaculture Sign Program contact:
Program regulations and/or general questions: Scott Marshall, R.I.D.E.M., 401-222-2781 ext.2774503. Sign requirements, standards and/or Installations., Phillip Magano, R.I.D.O.T., at 222-2694 ext. 4243.

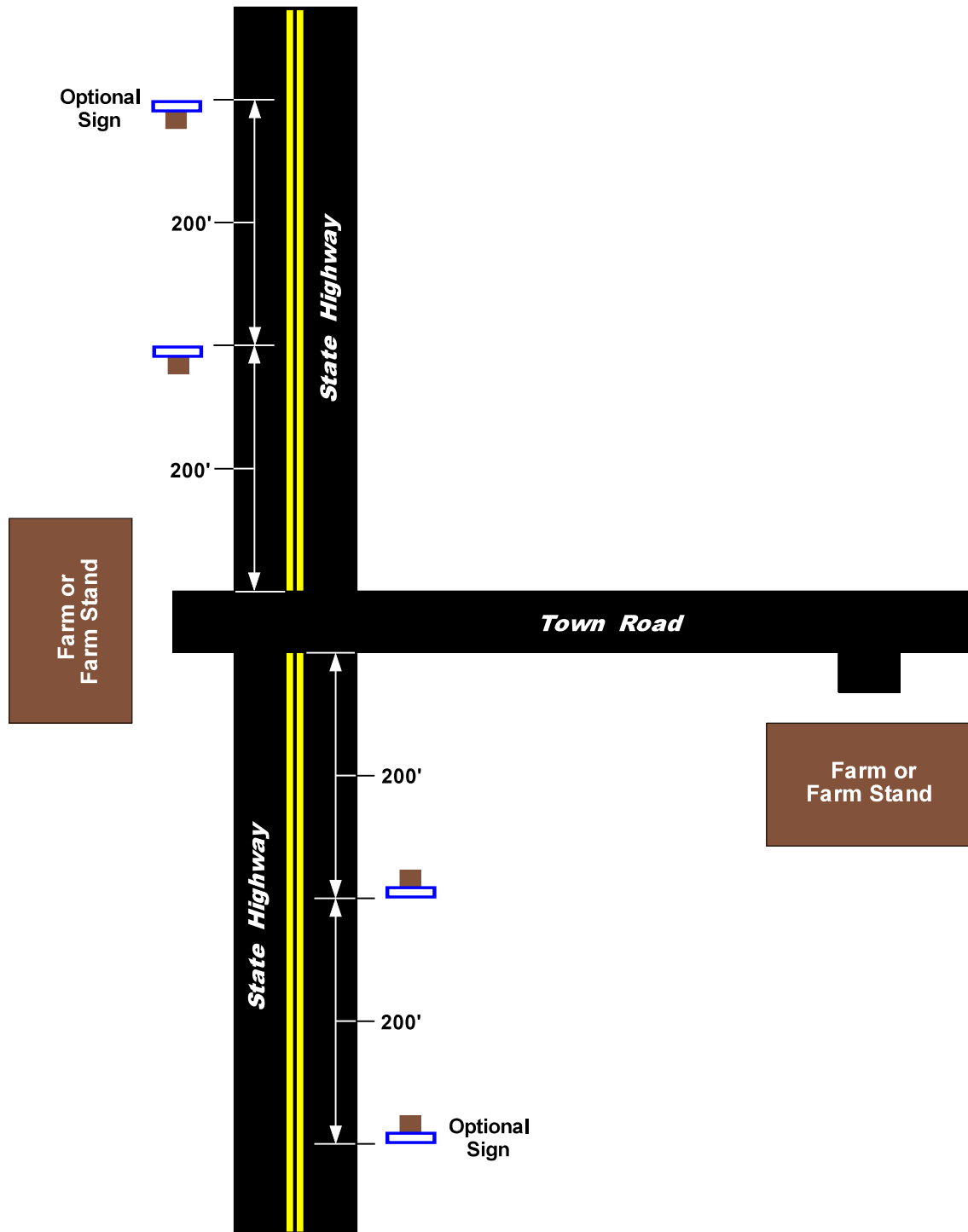

NOTE:

Sign distance, as shown above are typical, and may be changed. All sign locations will be determined by R.I.D.O.T.

AGRICULTURE FARM SIGN

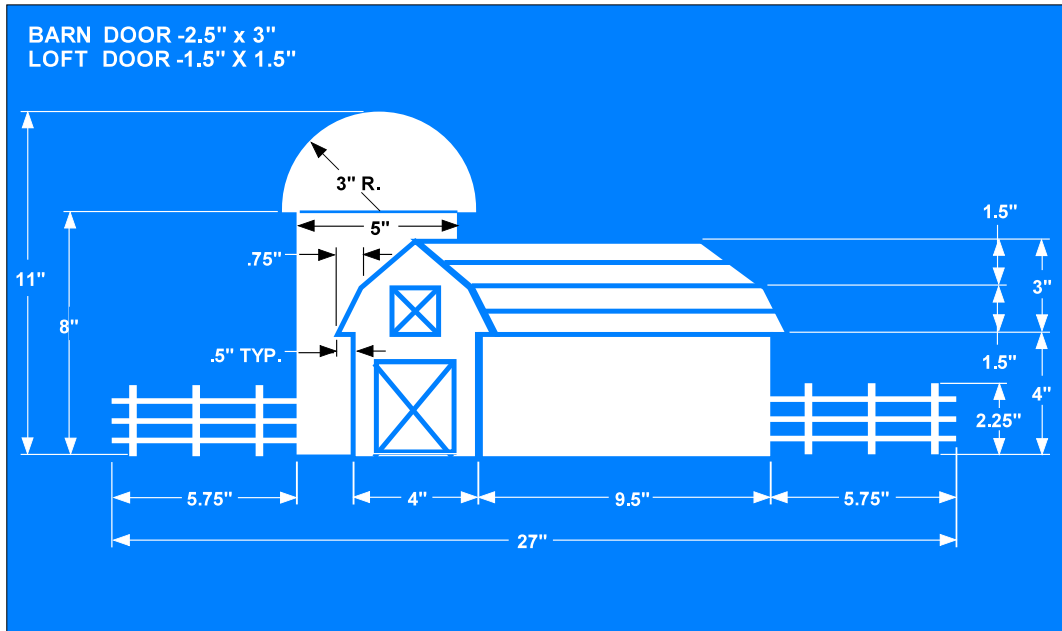
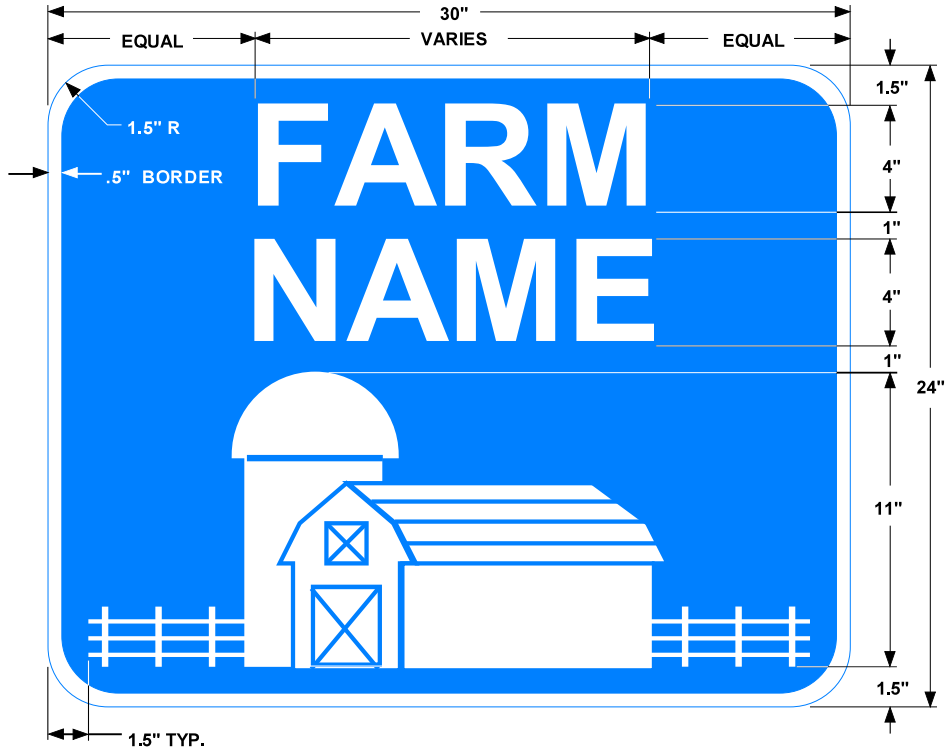

DRAWINGS NOT TO SCALE

NOTE:

***Blue Background - White Legend, Border & Farm Symbol.
Sign panels shall be 0.08 gauge aluminum.***

AQUACULTURE FARM SIGN

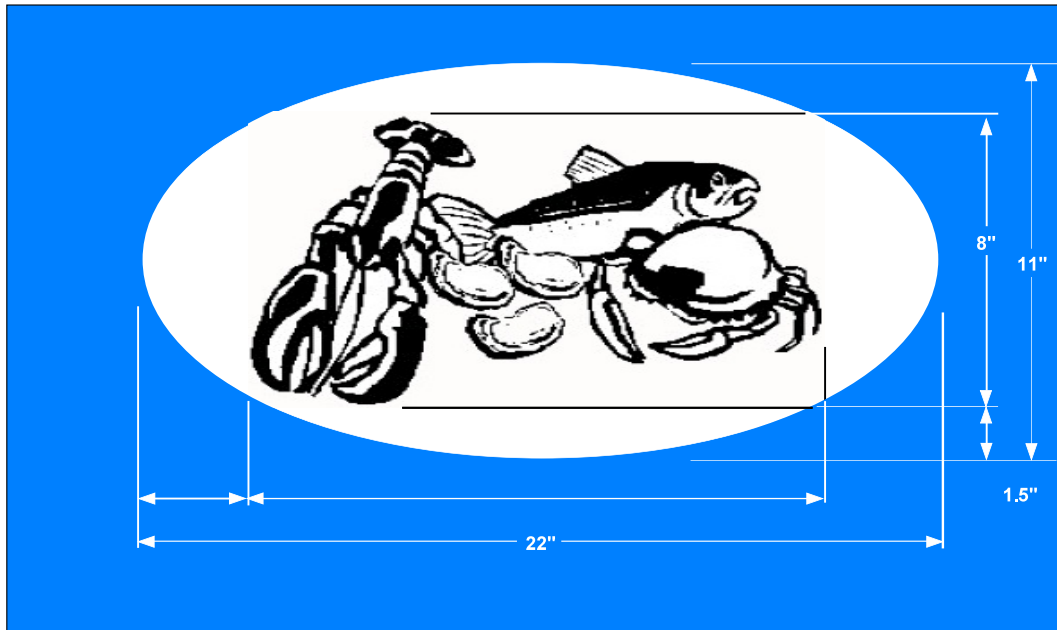
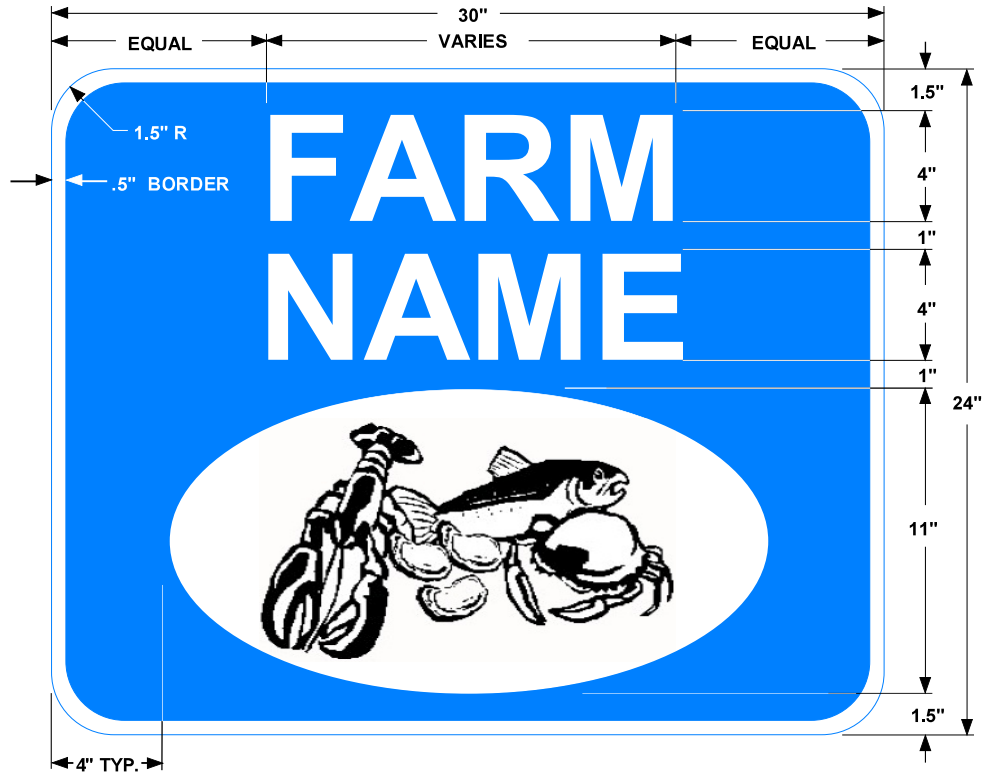

DRAWINGS NOT TO SCALE

NOTE:

***Blue Background - White Legend, Border & Ellipse - Black Seafood Symbol.
(Contact R.I.D.O.T. for the Seafood Clipart)
Sign panels shall be 0.08 gauge aluminum.***

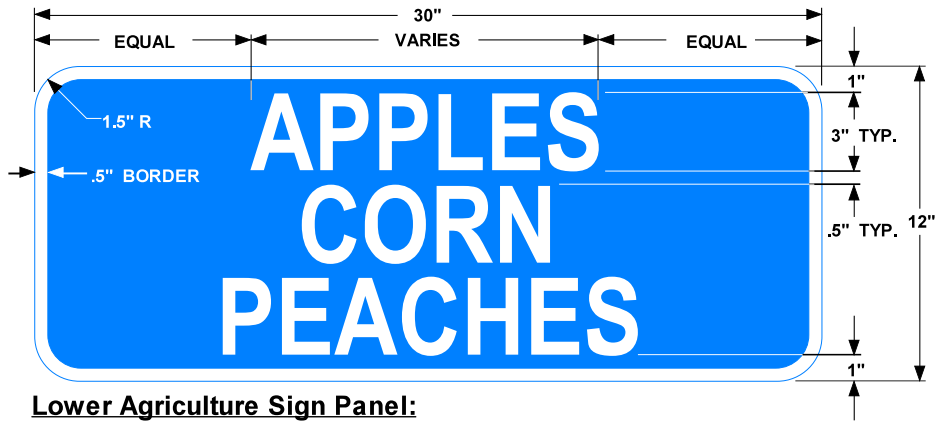

Lower Agriculture Sign Panel:
Maximum of 3 Produce Items.

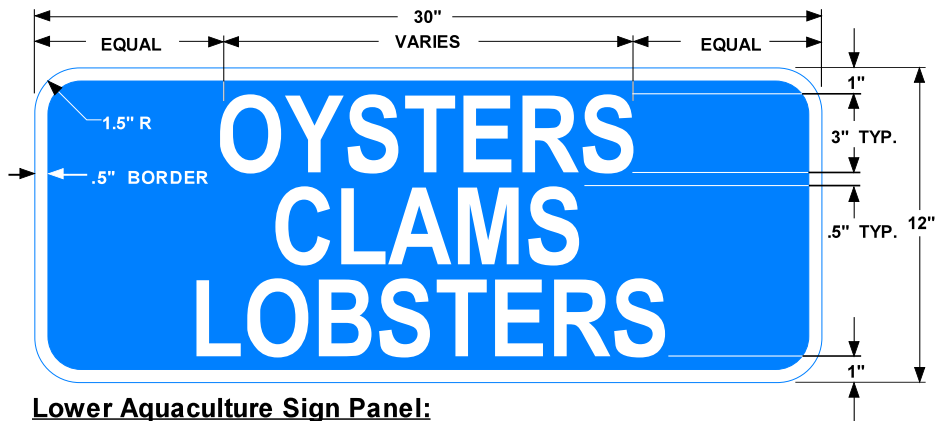

Lower Aquaculture Sign Panel:
Maximum of 3 Seafood Items.

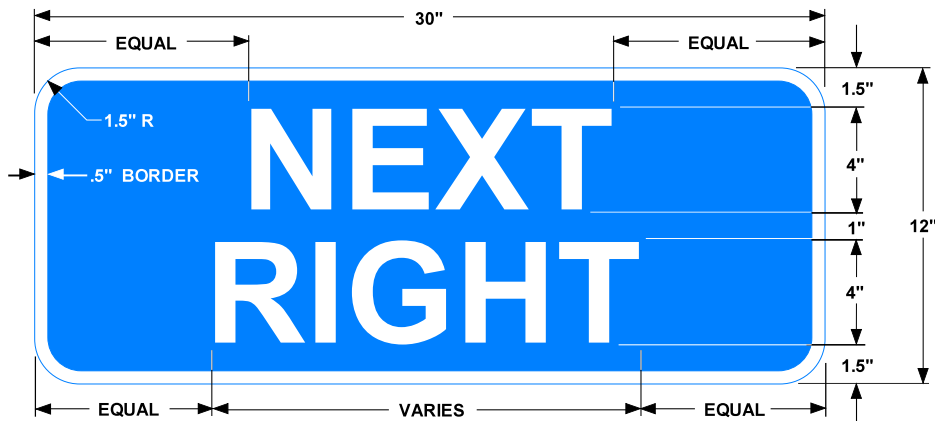

Lower Optional Sign Panel:
 "NEXT RIGHT" or "NEXT LEFT"
 "AHEAD" may also be used. (Center the 4" Legend)

DRAWINGS NOT TO SCALE

NOTES:

*Blue Background - White Legend & Border.
 Sign panels shall be 0.08 gauge aluminum.*

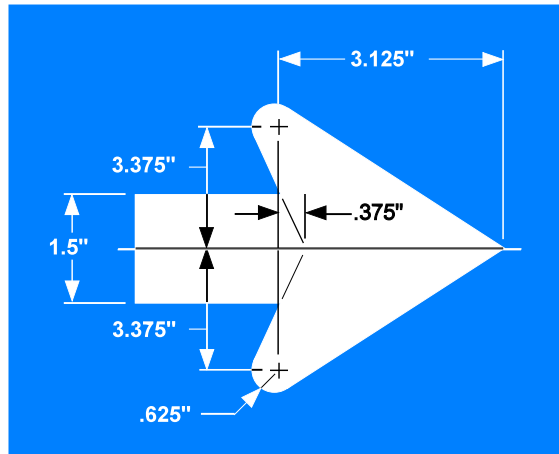
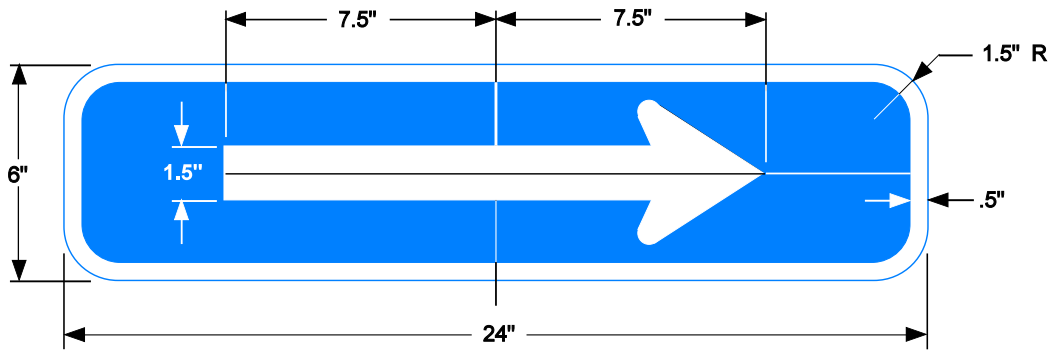

NOT TO SCALE

NOTE:

***Blue Background - White Border & Arrow.
Sign panels shall be 0.08 gauge aluminum.***

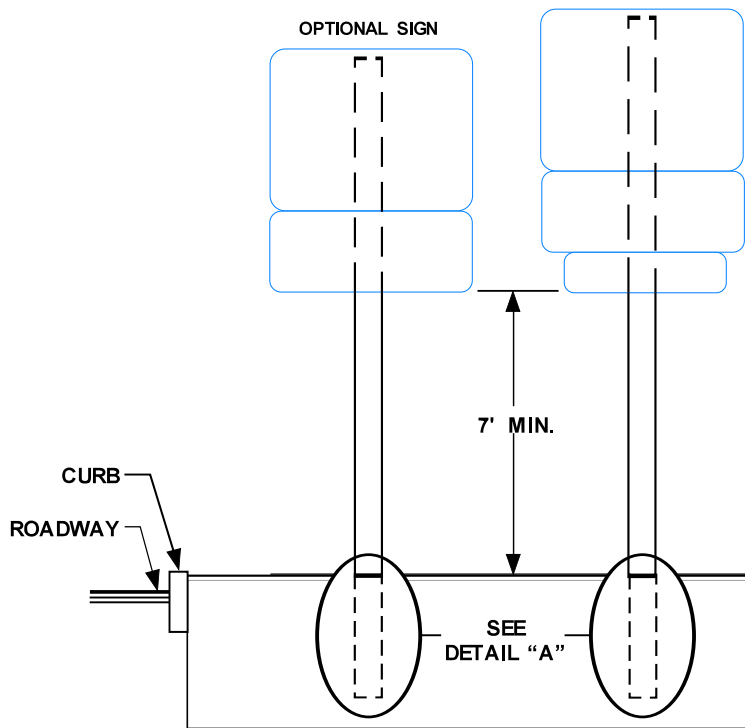

OPTIONAL SIGN

Sign Examples

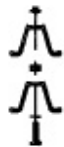

RECOMMENDED TORQUE VALUES:
 BOLTS TO THREADED BAR SPACER
 20 FT. LBS.
 SELF-LOCKING FLANGE NUT TO BOLTS
 20 FT. LBS.

TOP VIEW

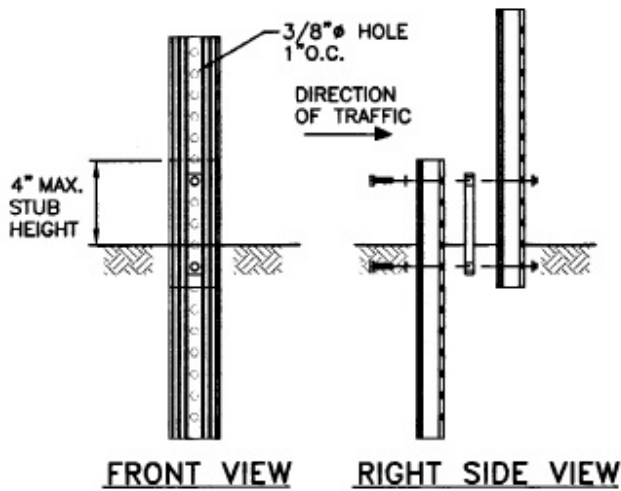

FRONT VIEW

RIGHT SIDE VIEW

4 LB./FT. RIB-BAK U-CHANNEL POST

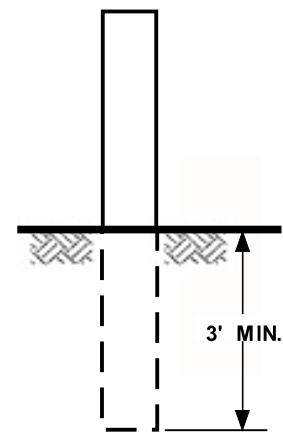

4" X 4"
 PRESURE TREATED POST

DETAIL "A"