

March 7, 2011  
File No. 32795.14-C



Mr. Mark Mageau  
14 River Street  
Wood River Junction, Rhode Island 02894

Re: Water Treatment System Decommissioning  
14 River Street  
Richmond, Rhode Island

530 Broadway  
Providence  
Rhode Island  
02909  
401-421-4140  
Fax: 401-751-8613  
<http://www.gza.com>

Dear Mr. Mageau:

As you know, GZA GeoEnvironmental, Inc. has been retained by Charbert, Division of NFA Corp. to assist with the installation and monitoring of the potable water treatment systems at your 14 River Street property since 2005. On January 27, 2011 the Rhode Island Department of Environmental Management (RIDEM) and the Rhode Island Department of Health (RIDOH) approved a residential well water treatment system decommissioning plan for the treatment system at your home. A copy of their letter is attached for your use. Their decision was based on a review of the groundwater quality data collected quarterly by GZA over the last calendar year.

At this time I would like to thank you for the time and patience you extended to GZA over the past six years, it has been our pleasure working with you. As was agreed to at the time of the system installation, you may keep the treatment system installed at your house at no cost to you, or Charbert will remove the system and restore your plumbing to the pre-installation configuration also at no charge to you. Your water treatment system (WTS) consists of four main components, water softening and iron removal, particulate filtration, carbon absorption and ultraviolet disinfection. Below is a description of each component:

- The first component of the WTS is the Culligan Soft-Minder Twin 90 water softener installed for water softening and iron removal. This twin tank model utilizes one tank until approximately 1,000 gallons of water passes through the system. After 1,000 gallons, the unit automatically switched to the other tank and regenerates the first tank. The tanks are regenerated by drawing a salt solution from a separate salt holding tank (see attached literature). Each recharge utilizes approximately 40 gallons of water that is discharged to the sanitary sewer system.
- Following the softener, a #10 Big Blue filter housing with DGD Series Dual-Gradient Density Filters (25 to 1 micron) collect any particulates prior to the activated carbon tank (see attached literature).



- To remove organic contaminants from the water, two 3.3 cubic foot activated carbon filter canisters were installed. Each canister holds 90 pounds of dry activated carbon. The canisters are installed in series such that the second canister will catch any contaminant breakthrough from the first.
- The final component in the WTS is a Culligan Aquada Ultraviolet disinfection unit, Model Maxima M2. The device is designed to treat flows up to 10 gallons per minute (gpm) and is equipped with a flow reducer to prevent flows of greater than 10 gpm from passing through the system. For maintenance and observation purposes, a water meter was installed between the carbon canisters and the disinfection unit.

Operation and maintenance manuals and other pertinent literature pertaining to the components of the WTS are attached to this document for your use. You will be responsible for the maintenance of the system if you choose to keep the system or a portion of the system. The minimum required maintenance is detailed below. For your information, GZA has attached a price quote from Northeast Water solutions, Inc., for the maintenance items listed below.

COMPONENT	REQUIRED MAINTENANCE
Twin Tank Ion Exchange Water Softener	Fill The Salt/Brine Basin Every Three Months, Requires 3 to 5 Bags of Iron Removal Salt
Cartridge Filter	Change Filter Cartridge Every Three Months.
Ultraviolet Lamp	Change The Bulb and Clean Internal Sleeve Yearly.
Granular Activated Carbon	Change as Required Based on Laboratory Analysis of Water Samples for Volatile and Semi-Volatile Organic Compounds.

GZA will contact you by telephone to discuss the system removal the week of March 14, 2011 and would appreciate your decision by April 7, 2011. GZA will have their contractor, Northeast Water Solutions, Inc.; remove the used carbon from the carbon vessels. If you choose to keep the entire water treatment system you will be responsible for the cost of installing new activated carbon at that time (approximately \$1,053.00). If you choose to remove the full system or certain system components that you do not wish to keep and restore your plumbing to the pre-installation configuration. Northeast Water Service will make the modifications at the time of carbon removal. This will be your only chance to have the system removed at no charge to you. If you do not elect to have Charbert remove the system now and later choose to remove it, you will have to do so at your own expense.



If you have any questions, please feel free to contact Ed Summerly or Stephen Andrus at (401) 421-4140 or Richard Amirault of the Rhode Island Department of Health at (401) 222-2231.

Very truly yours,

GZA GEOENVIRONMENTAL, INC.

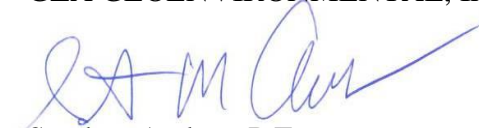
  
Stephen Andrus, P.E.  
Assistant Project Manager

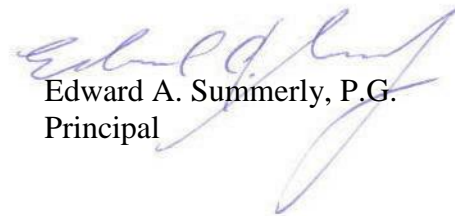
  
Edward A. Summerly, P.G.  
Principal

SA/EAS:blm

Attachments: RIDEM Decommissioning Approval Letter  
Northeast Water Solutions Maintenance Cost  
Water Treatment System Component Manuals

- Culligan Soft-Minder Twin 90 Water Softener
- Filter Housing (#10) and Cartridges
- Culligan Aquada Ultraviolet-Model Maxima-M2
- Calgon Activated Carbon Information

cc: Gary Jablonski, RIDEM (1-Copy and CD)  
Richard Amirault, RIDOH (1-Copy)  
Tracey Nelson Hay, Richmond Town Hall (CD Only)  
Clark Memorial Library (CD Only)

**RIDEM CORRESPONDENCE**



RHODE ISLAND  
DEPARTMENT OF ENVIRONMENTAL MANAGEMENT

235 Promenade Street, Providence, RI 02908-5767

TDD 401-222-4462

27 January 2011

RECEIVED  
FEB 01 2011  
GZA

Edward Summerly, P.G.  
GZA GeoEnvironmental, Inc.  
530 Broadway  
Providence, Rhode Island 02909

RE: Residential Drinking Water Treatment Systems  
Residence No.'s 14, 16, and 18 River Street  
Former Charbert Manufacturing Facility

Dear Mr. Summerly;

The Rhode Island Department of Environmental Management (the Department) and the Rhode Island Department of Health (DOH) have reviewed GZA's letter dated 15 December 2010 which outlines GZA's request for decommissioning of the residential drinking water treatment systems located at 14, 16, and 18 River Street located adjacent to the Charbert Facility, Alton, RI.

The additional, Department and DOH requested, sampling data collected during the last calendar year on a quarterly basis demonstrated that the untreated well water at all three River Street residences has been compliant with the RIDEM GA Groundwater Objectives. The on-site wastewater discharge lagoons 1, 2, and 3 have been properly closed and decommissioned in accordance to the Office of Water Resources. Also, the air sparge and vent system has been installed and is currently operating at the Site.

After review of this request and reviewing the remedial objectives for the residential treatment systems, the Department approves this request dated 15 December 2010 for the decommissioning of the private well treatment systems at 14, 16, and 18 River Street.

As stated in your request for decommissioning letter page 4: "*Charbert has agreed to leave the systems in place and give the equipment to those residents who would like to continue operation of their systems*". Please contact the three residents in writing, provide copies of these letters to the Department and DOH, notifying them of the Department's approval of the decommissioning of the residential treatment systems. In the letters please provide them with the opportunity to keep their treatment systems in place as long as they agree to and understand that the water treatment systems will require future routine maintenance, by the individual homeowner, to operate properly.

If you have any questions in regards to this letter please contact me at (401) 222 – 2797, extension 7148 or by e-mail at gary.jablonski@dem.ri.gov.

Sincerely,



Gary J. Jablonski, Principal Engineer  
Office of Waste Management

cc: Matthew DeStefano, RIDEM  
✓ Stephen Andrus, P.E., GZA  
Richard Amirault, RIDOH  
Tracy Nelson-Hay, Richmond Town Hall  
Clark Memorial Library, Charbert Repository

Res treatment ltr 012111





RHODE ISLAND  
DEPARTMENT OF ENVIRONMENTAL MANAGEMENT

235 Promenade Street, Providence, RI 02908-5767

TDD 401-222-4462

27 January 2011

Mr. Mark Mageau  
14 River Street  
Wood River Junction, RI 02894

RE: Residential Drinking Water Treatment System  
Residence No. 14 River Street

Dear Mr. Mageau;

As you are aware of, since January 2005 GZA GeoEnvironmental, Inc. has been retained by Charbert, Division of NFA Corp. to assist with the installation, routine maintenance, and monitoring of the potable water treatment system at your 14 River Street property. This work was conducted in compliance with the 29 June 2005 *Consent Agreement between Charbert and the Rhode Island Department of Environmental Management (RIDEM)*.

GZA presented a decommissioning plan for the potable water treatment system to RIDEM in a letter dated 4 November 2009. RIDEM and the Department of Health (DOH) reviewed this letter and requested that GZA conduct laboratory sampling of the untreated well water at your treatment system for the four quarters of the calendar year of 2010.

GZA presented to RIDEM and DOH in a letter dated 15 December 2010 a request for decommissioning of the residential drinking water treatment system located at 14 River Street. The additional sampling data collected during the last calendar year of 2010 on a quarterly basis was consistent with previous data that demonstrated that the untreated well water at 14 River Street is compliant with the RIDEM GA Groundwater Objectives and the Environmental Protection Agency's safe drinking water Maximum Contaminant Limit (MCL).

The on-site wastewater discharge lagoons 1, 2, and 3 have been properly closed and decommissioned in accordance to the Office of Water Resources. Also, the air sparge and vent system has been installed and is currently operating at the Site. Taking this into account and after RIDEM's review of this GZA request and the remedial objectives for the residential treatment systems, RIDEM will be approving GZA's request dated 15 December 2010 for the decommissioning of the private well treatment system at 14 River Street.

As stated in GZA's request for decommissioning letter page 4: "*Charbert has agreed to leave the systems in place and give the equipment to those residents who would like to*

*continue operation of their systems*". GZA will be in contact with you, in the near future, notifying you of RIDEM's approval of the decommissioning of the residential treatment system. GZA will provide you with the opportunity to keep your treatment system in place, carbon filters removed, as long as you agree to and understand that the water treatment system will require future routine maintenance, by yourself or a qualified maintenance company, to operate properly. This future routine maintenance of your individual treatment system will be at your cost. If you choose, GZA will offer to you the opportunity for GZA to completely remove your treatment system and reassemble your original plumbing as necessary and appropriate at no cost to you.

If you have any questions in regards to this letter please contact me at (401) 222 – 2797, extension 7148 or by e-mail at [gary.jablonski@dem.ri.gov](mailto:gary.jablonski@dem.ri.gov) or Richard Amirault at (401) 222-7762 or by email at [richard.amirault@health.ri.gov](mailto:richard.amirault@health.ri.gov) .

Sincerely,



Gary J. Jablonski, Principal Engineer  
Office of Waste Management

cc:     Matthew DeStefano, RIDEM  
      ✓ Stephen Andrus, P.E., GZA  
      Richard Amirault, RIDOH  
      Tracy Nelson-Hay, Richmond Town Hall  
      Clark Memorial Library, Charbert Repository



**NORTHEAST WATER SOLUTIONS MAINTENANCE COST**



N O R T H E A S T  
**Water Solutions**  
I N C .

# Memo

**To:** Stephen Andrus

**From:** Larry Anderson

**CC:**

**Date:** 03-04-11

**Re:** Residential Water Systems - Alton-

---

Quarterly site visit for salt delivery and filter change cost: 50# bag of Water Softener Salt \$15.72 per bag (4) bag minimum required.

Filters (1) 4x10 25-1 micron \$16.38 each

(1) 4x 20 25-01 micron \$30.26 each.

Replacement of U V bulb with sleeve and o rings \$ 180.00 (est. one per year) Service call and labor \$150.00

Re-bedding vessels with F 400 NSF Granulated Activated Carbon (2) cubic ft per vessel total of (2) vessels per location. \$ 778.00 plus labor est. \$275.

Single carbon vessel change out. \$400.00 plus labor \$190.00

**Note:** all spent carbon shall be placed in container provided by owner.  
Owner shall be responsible for disposal of spent carbon.

Prices subject to RI 7% sales tax

NWSI

Larry Anderson VP

NORTHEAST WATER SOLUTIONS, INC.  
567 South County Trail Suite 116  
Exeter, RI 02822

401-667-7463 X129 Cell 401-829-1952  
Fax 401-667-7465

**WATER TREATMENT SYSTEM COMPONENT MANUALS**

**Cat. No. 01017141**

Rev. A 11/25/03

DCO # 6711

Owners Guide &  
Installation Instruction  
Supplement

**SOFT-MINDER<sup>®</sup> TWIN  
w/ACME THREADS  
MODELS FROM 2003**

**Culligan<sup>®</sup>**



## Thank You

### And welcome to your new world of better living with Culligan water.

The Culligan Soft-Minder Twin™ Water Softeners are tested and certified by WQA according to WQA S-100 for hardness reduction (calcium and magnesium).

**For installations in Massachusetts, the Commonwealth of Massachusetts Plumbing Code 248 CMR shall be adhered to. Consult your licensed plumber for installation of the system. This system and its installation must comply with state and local regulations.**



If this is your first experience having soft, conditioned water in your home, you'll be amazed at the marvelous difference it makes. We promise that you'll never want to be without it again.

Congratulations, too, on selecting one of the "first family" of water conditioners in the prestigious Culligan Gold Series. With Culligan's many years of knowledge and experience in water treatment, you can be confident that the model you selected has been designed and engineered to provide years of service with a minimum of care and attention.

Some localities have corrosive water. A water softener cannot correct this problem and so its printed warranty disclaims liability for corrosion of plumbing lines, fixtures or appliances. If you suspect corrosion, your Culligan Dealer has equipment to control the problem.

**Sodium Information:** *Water softeners using sodium chloride for regeneration add sodium to the water. Persons who are on sodium restricted diets should consider the added sodium as part of their overall sodium intake.*

#### **Attention Culligan Customer:**

Your local independently operated Culligan dealer employs trained service and maintenance personnel who are experienced in the installation, function and repair of Culligan equipment. This publication is written specifically for these individuals and is intended for their use.

We encourage Culligan users to learn about Culligan products, but we believe that product knowledge is best obtained by consulting with your Culligan dealer. Untrained individuals who use this manual assume the risk of any resulting property damage or personal injury.



**WARNING - Prior to servicing equipment, disconnect power supply to prevent electrical shock.**

# Owners Guide & Installation Instruction Supplement

## **SOFT-MINDER® TWIN w/ACME THREADS MODELS FROM 2003**

- Culligan Soft-Minder Twin 60 Water Softener**
- Culligan Soft-Minder Twin 90 Water Softener**

### *Table of Contents*

	<b>Page</b>
Specifications .....	2
Introduction.....	3
Preparation.....	5
Application .....	6
Installation .....	9
Sanitizing Procedure .....	10
Service .....	11
Care & Cleaning.....	12
Culligan 60 Soft-Minder Twin Performance Data Sheet ..	15
Culligan 90 Soft-Minder Twin Performance Data Sheet ..	16
Warranty .....	17
Parts List .....	18

Performance Data Sheets are included in this manual for various Culligan Soft-Minder Twin™ Softener models. Refer to the Performance Data Sheet for your specific softener, as there are slight differences between the models. The softener warranty is located on page 18 of this Owner's Guide.

# Specifications

## Culligan Soft-Minder Twin™ Water Conditioners

	<b>60 Model</b>	<b>90 Model</b>
Control Valve	5-cycle	5-cycle
Overall Conditioner Height	56 in. (142.24 cm)	62 in. (157.48 cm)
Media Tank Dimensions (Dia. x Ht.)	9 x 48 in.	10 x 54 in.
Salt Storage Tank Dimensions (Dia. x Ht.)	16 x 43 in. 406 x 1,092 mm	18 x 43 in. 457 x 1,092 mm
Exchange Media, Type & Quantity	Cullex® Media, 1.0 ft³	Cullex Media, 1.5 ft³
Underbedding, Type & Quantity	Cullsán Underbedding, 12 lb.	Cullsán Underbedding, 15 lb.
Exchange Capacity @ Salt	14,600 gr @ 3 lb.	21,900 gr @ 4.5 lb.
Dosage Per Recharge	29,400 gr @ 9 lb. 33,800 gr @ 15 lb.	44,000 gr @ 13.5 lb. 50,700 gr @ 22.5 lb.
Efficiency rated dosage¹	4,880 gr/lb	4,880 gr/lb
Freeboard to Media²	14.5 in.	14.5 in.
Freeboard to Underbedding³	44.5 in.	47.5 in.
Salt Storage Capacity	350 lb.	375 lb.
Rated Service Flow @ Pressure Drop	10.4 gpm @ 15 psi	10.4 gpm @ 15 psi
Total Hardness, Maximum	75 gpg	99 gpg
Total Iron, Maximum (dissolved)	5 ppm	5 ppm
Hardness to Iron Ratio, Minimum	8 gpg to 1 ppm 140 mg/L to 1 mg/L	8 gpg to 1 ppm 140 mg/L to 1 mg/L
Operating Pressure	20 - 125 psi	20 - 125 psi
Operating Pressure (Canada)	20 - 90 psi	20 - 90 psi
Operating Temperature	33 - 120°F	33 - 120°F
Electrical Requirements	120V/60 Hz	120V/60 Hz
Electrical Power Consumption, Min./Max.	3 Watts	3 Watts
Drain Flow, Maximum⁴	2.0 gpm	2.0 gpm
Recharge Time, Average⁵	65 min.	70 min.
Recharge Water Consumption	55 gal.	110 gal.

1 The efficiency rated dosage is only valid at the 3.0 lb. salt dosage for the model 60 and 4.5 lb. salt dosage for the model 90.

2 Measured from top of media to top surface of tank threads (backwashed and drained).

3 Measured from top of underbedding to top of inlet fitting.

4 Backwash at 120 psi (830 kPa).

5 10 minute backwash, 3 lb. (1.8 kg) model 60 or 4.5 lb. (2.7 kg) model 90 salt dosage at 30 psi (204 kPa).

## **IT'S ALL SO EASY, SO ECONOMICAL, SO EFFICIENT, SO ENJOYABLE!**

### **KIND TO SKIN AND COMPLEXION**

Soft water will help prevent red, itchy or dry skin because there are no hardness impurities to cause soreness, no soap curd to coat the skin. Shaving is easier, smoother - either with blade or electric shaver.

### **BATHING AND SHOWERING**

You'll use far less soap with conditioned water. Use your soap very sparingly - not as you did before soft water. Just a quick rinse removes all lather, leaving your skin pleasantly smooth and silky - because now it's free of sticky soap curd and film.

### **SAVES WASHING COSTS. HELPS CONTROL ENVIRONMENTAL POLLUTION**

Soft water washes whiter and cleaner with less soap or detergent. Because the hardness impurities are removed, your soap can concentrate solely on washing. People usually find that they can reduce the amount of soap they use substantially. If you normally used a cup per wash load with hard water, try using only 1/3 cup depending on the size of your wash load and the degree of soil. Different amounts are required, but you can use less with softened water. An added bonus is the fact that your washable fabrics will last longer.

### **SUPER HAIR CONDITIONING**

Soft water is great for scalp and hair care. No insoluble deposits are formed. Hair is shinier, softer, more manageable. Reduce the amount of shampoo you have normally used.

### **DISHES ARE A DELIGHT**

Washed by hand or in a dishwasher, glassware, dishes and silver wash cleaner, easier. Follow your dishwasher manufacturer's instructions. Soft water promotes sanitation because no greasy hard water film can form to collect or harbor bacteria.

### **EASIER HOUSEKEEPING, GLEAMING FIXTURES**

You'll be amazed at the marvelous difference. Just a swish of the cloth, and the bathtub or shower and fixtures are clean and sparkling. Imagine, no scouring! No hard water scum to cause rings, streaks, spots and stains. To keep their gleaming luster, simply wipe fixtures with a towel after use. Formica, tile, walls, floors, woodwork surfaces clean easier, stay clean longer. You'll save on cleaning aids and save on time.

### **SAVES WATER-HEATING ENERGY, HELPS WATER-USING APPLIANCES**

Soft water reduces the formation of rock-like hard water scale which encrusts water heaters, hot water pipes, shower heads, and water-using appliances. This scale can cause premature maintenance and failure.

Elimination of hard water also provides substantial energy savings because scale acts as an insulator, wasting electricity or gas used to heat water.

### **SAVINGS GALORE**

A water conditioner is frequently referred to as "the appliance that pays for itself". You'll find that your savings on soaps, detergents, cleaning aids, and personal care products will help your family's household budget. And if you place a price on your time, you'll be most happy with the time saved by your new family servant.

### **WATER FOR LAWNS AND HOUSEHOLD PLANTS**

If possible, lawn sprinkling faucets should be supplied with hard water primarily because it is uneconomical to soften so much water.

Household plants are much more sensitive than lawns with respect to the kind of water which is best. First, because they receive no rainfall and, second, there is little or no drainage of the soil. Preferably they should be watered with rain water or water which is low in mineral content such as distilled or demineralized water. Softened water is not recommended for house plants because a build-up of sodium in the soil may interfere with efficient absorption of water by the plant root system. Additional information may be obtained from your independently operated Culligan dealer.



# Introduction

## How Your Water Conditioner Works

### Why Water Gets Hard And How It's Softened

All of the fresh water in the world originally falls as rain, snow, or sleet. Surface water is drawn upward by the sun, forming clouds. Then, nearly pure and soft as it starts to fall, it begins to collect impurities as it passes through smog and dust-laden atmosphere. And as it seeps through soil and rocks it gathers hardness, rust, acid, unpleasant tastes and odors.

Water hardness is caused primarily by limestone dissolved from the earth by rainwater. Because of this, in earlier times people who wanted soft water collected rainwater from roofs in rain barrels and cisterns before it picked up hardness from the earth.

Some localities have corrosive water. A softener cannot correct this problem and so its printed warranty disclaims liability for corrosion of plumbing lines, fixtures or appliances. If you suspect corrosion, your Culligan Man has equipment to control the problem.

Iron is a common water problem. The chemical/physical nature of iron found in natural water supplies is exhibited in four general types:

1. Dissolved Iron - Also called ferrous or "clear water" iron. This type of iron can be removed from the water by the same ion exchange principle that removes the hardness elements, calcium and magnesium. Dissolved iron is soluble in water and is detected by taking a sample of the water to be treated in a clear glass. The water in the glass is initially clear, but on standing exposed to the air, it may gradually turn cloudy or colored as it oxidizes.
2. Particulate Iron - Also called ferric or colloidal iron. This type of iron is an undissolved particle of iron. A softener will remove larger particles, but they may not be washed out in regeneration effectively and will eventually foul the ion exchange resin. A filtering treatment will be required to remove this type of iron.
3. Organic Bound Iron - This type of iron is strongly attached to an organic compound in the water. The ion exchange process alone cannot break this attachment and the softener will not remove this type of iron.
4. Bacterial Iron - This type of iron is protected inside a bacteria cell. Like the organic bound iron, it is not removed by a water softener.

When using a softener to remove both hardness and dissolved iron it is important that it regenerates more frequently than ordinarily would be calculated for hardness removal alone. Although many factors and formulas have been used to determine this frequency, it is recommended that the softener be regenerated when it has reached 50 - 75% of the calculated hardness alone capacity. This will minimize the potential for bed fouling (Iron removal claims have not been verified by the Water Quality Association).

If you are operating a water softener on clear water iron, regular resin bed cleaning is needed to keep the be from coating with iron. Even when operating a softener on water with less than the maximum of dissolved iron, regular cleanings should be performed. Clean every six months or more often if iron appears in your conditioned water supply. Use resin bed cleaning compounds carefully following the directions on the container.



**CAUTION: Do not use where the water is microbiologically unsafe or with water of unknown quality without adequate disinfection before or after the unit.**

Hardness sample kits are available through your local Culligan dealer.

## The Culligan Process

Your Culligan water conditioner consists of three basic components, (A) the Control Valve, (B) the Mineral Tank, and (C) the Brine System.

- A. The exclusive Culligan control valve automatically performs a variety of tasks that are necessary for the proper operation of your water conditioner. These tasks, commonly referred to as cycles or operating positions, are:

### SERVICE, REGENERATION, AND BRINE REFILL.

1. **SERVICE:** While the control valve is in the “Service cycle”, hard water is directed down through the column of Cullex® resin where hardness minerals are removed from the water. The softened water is then directed into your household plumbing lines. The ability of the Cullex resin to remove hardness minerals needs to be periodically replenished; this is referred to as . . .
2. **REGENERATION:** While the control valve is in the “Regeneration cycle”, water is first directed up through the column of Cullex resin to flush accumulated sediment out of the resin and down the drain. Then, the regenerant brine solution is slowly drawn from the bottom of the salt storage tank of the Brine System and is directed down through the column of Cullex resin, restoring the ability of the resin to remove hardness minerals from your water supply. Once completed, the regeneration cycle is followed by . . .
3. **BRINE REFILL:** While the control valve is in the “Brine Refill cycle”, a predetermined amount of water is directed to the salt storage tank of the Brine System so that additional salt can be dissolved to provide the brine solution that will be needed for the next regeneration cycle.

- B. The exclusive Quadra-Hull™ Mineral Tank contains the Cullex resin column, Cullsan® underbedding, and an outlet manifold. The number of gallons of hard water that can be softened by the Cullex resin column before it needs regeneration is called the “capacity” of the resin column, and depends upon the amount of hardness minerals in each gallon of water (expressed as grains per gallon) and upon the amount of regenerant brine solution (expressed as pounds of salt) passed through the resin column during regeneration.

Your Culligan service person, taking into account the hardness of your water and the amount of softened water your household may reasonably expect to use each day, has carefully established how often the softener will regenerate and how much salt will be used for each regeneration. This will ensure that all of your soft water needs will be fulfilled without using an excessive amount of salt.

- C. The Brine System consists of a salt storage container and hydraulic Dubl-Safe™ valve. The salt storage container holds the salt that is used to make the regenerant brine solution. The hydraulic Dubl-Safe valve limits the amount of water that is returned to the salt storage tank during the brine refill cycle.

Since a predetermined amount of salt is dissolved with each brine refill cycle, the salt must be periodically replenished in order to maintain efficient operation. Your Culligan service person will be able to tell you about how often salt must be added to the salt storage container.

# Preparation

## WATER PRESSURE

A minimum water pressure of 25 lbs is necessary for the regeneration valve to operate properly.

## ELECTRICAL

The system requires a continuous current of 110 volts, 60 Hertz. Make certain the electrical supply is always hot and cannot be turned off with another switch.

## PLUMBING

The piping should be free from lime and iron buildup. Replace pipes that have a heavy build-up of lime or iron. If piping is clogged with iron, then a separate iron filter should be installed ahead of the water softener.

## LOCATION

Position the softener close to a drain and electrical outlet. (Fig. 1)

## BYPASS SYSTEM

A bypass valve is recommended for all installations.

## COMPONENT DESCRIPTION

The water conditioner is shipped in three cartons. Remove all components from the cartons, inspect for damage and inventory contents prior to starting the installation.

## CONTROL VALVE ASSEMBLY

Includes the regeneration control valve and electronic timer assembly. A small parts package contains installation hardware and consumer literature, including an Owner's Guide/Installation Supplement and warranty policy.

## MEDIA TANK

Contains the center opening Quadra-Hull™ tank complete with Cullex® ion exchange resin and outlet manifold.

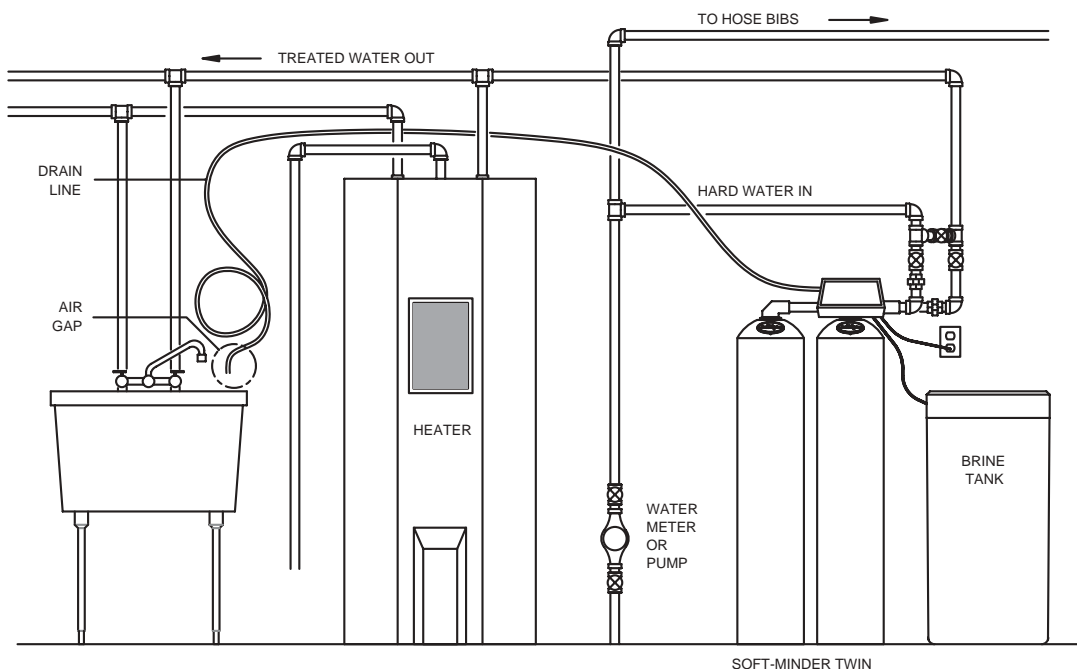

FIG. 1

## **SALT STORAGE TANK**

Includes a salt storage tank with support plate and Dubl-Safe™ brine refill valve and chamber.

## **TOOLS/EQUIPMENT**

Secure the following tools and equipment depending on installation method. Observe all applicable codes.

## **EQUIPMENT**

- Safety glasses
- Screwdrivers, Phillips, small/medium tip
- Pressure gauge, PN 00-3044-50
- Silicone lubricant, PN 00-4715-07
  - Do not use petroleum-based lubricants
- Bucket, light colored
- Towels

## **SPECIAL TOOLS**

- Torch, solder and flux for sweating copper connections
- Threading tools, pipe wrenches for threaded connections
- Saw, solvent and cement for plastics connections

## **MATERIALS**

- Brine line, 5/16", PN 00-3031-28
- Drain line, 1/2", PN 00-3031-82, gray, semi-flexible/PN 00-3319-46, black, semi-rigid
- Thread sealing tape
- Pressure reducing valve/when pressure exceeds 120 psi (830 kPa) PN 00-4009-00
- Pipe and fittings
- Water softener salt

## **BYPASS VALVE**

A bypass valve is included with the control valve assembly.

This supplement contains important information about the Soft-Minder Twin Plus automatic water conditioner, including instructions covering installation of the control valve, tank adapter, interconnecting piping between the two mineral tanks, and timer adjustments. For additional information, please refer to the Model 9000 Service manual packed with the control.

Before starting the installation, make certain the water meets the required limitations as shown in Table 1 (next page). Review the specifications for the unit to be certain all application requirements have been met. Also, carefully review the Model 9000 Service Manual, paying particular attention to the regeneration cycle program setting procedure.



# Application

## WATER QUALITY

Verify that the raw water hardness and iron are within the limits shown in Table 1. The salt dosage and recharge frequency should be noted according to the water hardness.

## PRESSURE

If pressure exceeds 120 psi (830 kPa), install a pressure reducing valve. On private water systems, make sure the minimum pressure (the pressure at which the pump starts) is greater than 20 psi (140 kPa). Adjust the pressure switch if necessary.



**CAUTION:** The use of a pressure reducing valve may limit the flow of water in the household.

## TEMPERATURE

Water temperature is not to exceed 110°F. Do not install the unit where it might freeze or next to a water heater, furnace or in direct sunlight.

## LOCATION

### Space Requirements

Allow 6-12 inches (150-300 mm) behind the unit for plumbing and drain lines and 4 feet (1.3 meters) above for service access and filling the salt tank.

### Floor Surface

Choose an area with a solid level floor free of bumps or irregularities. These floor conditions can cause the salt storage tank bottom to crack when filled with salt and water.

### Drain

Select a nearby drain that can handle the rated drain flow (floor drain, sink or stand pipe). The drain line should be a minimum of 1/2". Overhead drains exceeding 4' above unit require 3/4" drain line.

**NOTICE:** Waste connections or drain outlets shall be designed and constructed to provide for connection to the sanitary waste system through an air gap of 2 pipe diameters or 1 inch, whichever is larger.

**NOTICE:** Observe all plumbing codes. Most codes require an anti-siphon device or air gap at the discharge point. The system and installation must comply with state and local laws and regulations.

**NOTICE:** Observe all State and local electrical codes.

### Electrical

A 6 foot grounded cord is provided. It should be plugged into a 3-prong electrical outlet. Preferably one not controlled by a switch that can accidentally shut the unit down.



**WARNING! ELECTRICAL SHOCK HAZARD! DO NOT REMOVE THE GROUNDING PRONG. IF THE RECEPTACLE IS DESIGNED FOR A 2-PRONG PLUG. OBTAIN A 3-PRONG ADAPTER AND GROUND IT SECURELY. DO NOT USE EXTENSION CORDS.**

Table 1 - Water Limitations

	SM-60 TWIN	SM-90 TWIN
Hardness, Maximum (gpg)	60	90
Iron, Maximum (ppm)	5	5
Hardness (gpg) to Iron (ppm) ratio	8 to 1	8 to 1
Operating Pressure (psi)	20-120	20-120
Operating Temperature (°F)	33-120	33-120
Electrical Requirements	120 VAC/60 Hz	120 VAC/60 Hz

## PLACEMENT

- Set the media tanks on a solid, level surface that provides easy access to a water supply, drain system and electricity.
- Place the brine system on a flat, smooth, solid surface close to the media tank.
- Plumbing should comply with the applicable local plumbing codes.
- Two lengths of 1-inch copper tubing (Fig. 2) is required to connect the control valve on tank #1 to the adapter on tank #2. A minimum spacing of one inch between the media tanks is recommended. Use the following chart to provide the one-inch spacing.

Tank Diameter	Tube Length
9-inch	6-inch
10-inch	8-inch

- Solder the copper tubes to the two brass yokes.
- Use the steel u-clips to join components together. Be sure to use the 3/8-inch machine screws when securing the clips to the brass components. Use the 9/16-inch thread cutting screws when assembling the clips to plastic components.
- Lubricate the distributor and tank o-ring seal with silicone lubricant.
- The joints near the drain must be soldered prior to connecting the drain line flow control fitting (DLFC). Leave at least 6" between the DLFC and the joints when soldering. Failure to do this could cause damage to the drain module. Teflon tape is the only sealant to be used on the drain fittings.

## CONTROL VALVE

The control valve parts list on page 18/19 of the Model 9000 Service Manual shows item 35/36 button and retainer. These parts are not used on the Soft-Minder® Twin Control because the brine refill flow control is located in the body of the brine valve.

The programming regeneration cycle outlined in the Service manual is based on a 0/164 minute program wheel (2 minutes per pin hole). This control has 0/82 minute program wheel (1 minute per pin hole).

A white #1 eductor throat and nozzle is packaged with the control valve for use on the 9-inch tanks. The blue eductor throat and nozzle are used only with the 12-inch tank.

When changing the eductor nozzle and throat, remove the eductor assembly mounting screws. Carefully remove the eductor assembly from the control. Unscrew the eductor nozzle and throat and replace with the correct size eductor. Reassemble onto the control valve.

Included in the parts pack are (2) drain line flow controls with different gpm capacities. Tank size will determine which size flow control to install. Use the 2.00 gpm for the 9-inch tank and 10-inch tank.

Install the DLFC by removing the drain line elbow adapter. Unscrew the retainer, remove and replace with the proper size.

Install the retainer and the drain line elbow adapter. The numbered side of the DLFC must face down.

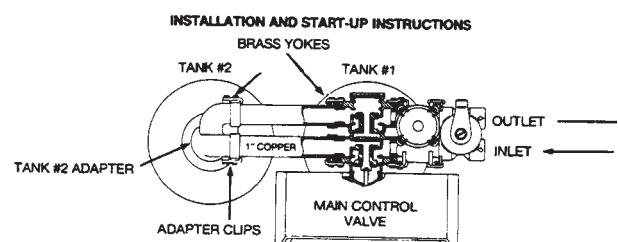

FIG. 2

# Installation

## START-UP

Place approximately 1" of water above the grid plate (if used) in your salt tank. Salt may be placed in the unit at this time.

Place softener in a bypass position. Turn on the main water supply and check for any leaks. Open a cold water faucet near the softener and run a few minutes until the system is free of any foreign material (usually solder) that may have resulted from the installation.

Shift the bypass into the service position so that water flows into the mineral tanks. When water flow stops, open a cold water faucet and allow to run until air pressure is relieved.

Electrical connections must be connected according to codes.

Plug unit into electrical outlet. Do not insert meter cable into the meter at this time.

## TIMER SETTINGS

The manual line drawings (Fig. 3) illustrate a 0/164 minute program wheel or 2 minute per pin hole. This control has 0/82 minute program wheel, 1 minute per pin hole. Each hole represents one minute of regeneration time.

## BACKWASH

The factory setting is 8 minutes (8 pins). To change the backwash time, add one pin to increase the backwash time by one minute. Decrease backwash time by removing a pin.

## BRINE/RINSE

The factory setting is 54 minutes (54 holes). When changing brine/rinse, move the rapid rinse group of pins clockwise to increase the brine/rinse time or counterclockwise to reduce brine/rinse time.

## TIMER SETTINGS

### Rapid Rinse

The factory setting is 6 minutes (6 pins). Change the rapid rinse time by adding pins (increase) or remove pins (decrease) at the higher numbered end of the rapid rinse section.

### Brine Tank Refill

Standard factory settings is 6 minutes (3 holes). Refer to Table 2, salt dosage vs. capacity, to determine if the settings require changing. When changing the refill time, move two pins at the end of the refill section.

**NOTICE:** The last two pins at the end of the refill section must not be eliminated. This will result in refill continuing until the timer advances to the service position.

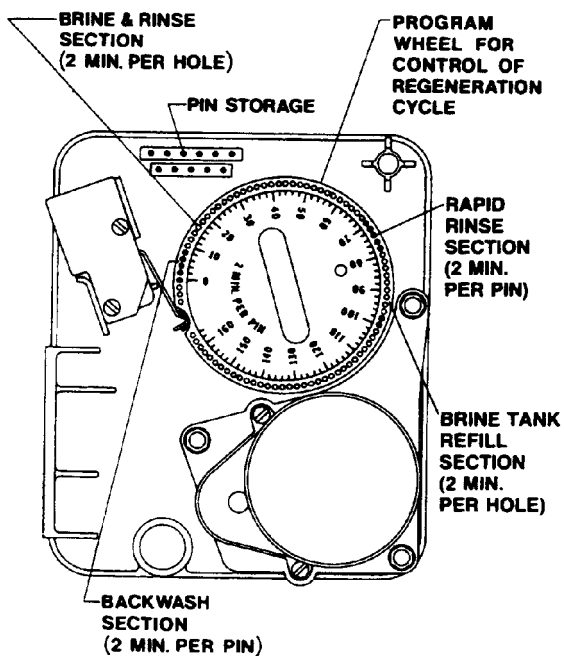

FIG. 3

# Installation

**Table 2 - Salt Dosage vs. Capacity vs. Timer Settings**

Tank Diameter	Salt Dosage (lbs.)	Capacity* (grains)	Refill Time (minutes)
9-inch	3	14,600	2
	9	29,400	7
	15	33,800	11
10-inch	4.5	21,900	3
	13.5	44,000	10
	22.5	50,700	17

**GALLON WHEEL SETTINGS**

The model 9000 valve regenerates with soft water from the other tank, you must subtract the water used for regeneration. If 1000 gallons are available then you must subtract the regeneration water used from the total water available.

If there are 1000 gallons available subtract the regeneration water used from total water available.

$$\begin{array}{rcl}
 1000 & & 51 \\
 \text{gallons} & - & \text{gallons} \\
 \text{available} & & \text{used} \\
 & & = \\
 & & 949 \\
 & & \text{gallons} \\
 & & \text{returning} \\
 & & \text{(in regeneration)}
 \end{array}$$

The meter wheel should be set at 950 gallons. Lift the inner dial of the meter program wheel (Fig. 4) so that it rotates freely. Position the white dot opposite the 950 gallon setting.

**NOTICE:** There is some delay from the time the meter zeros out and when the cycle starts. Typically on residential equipment this delay is not critical. In commercial applications this must be taken into consideration. These 9 and 18 minute continuous flows should be subtracted from the available water supply.

- Insert meter cable into the meter.
- Check bypass.
- Plug in unit.

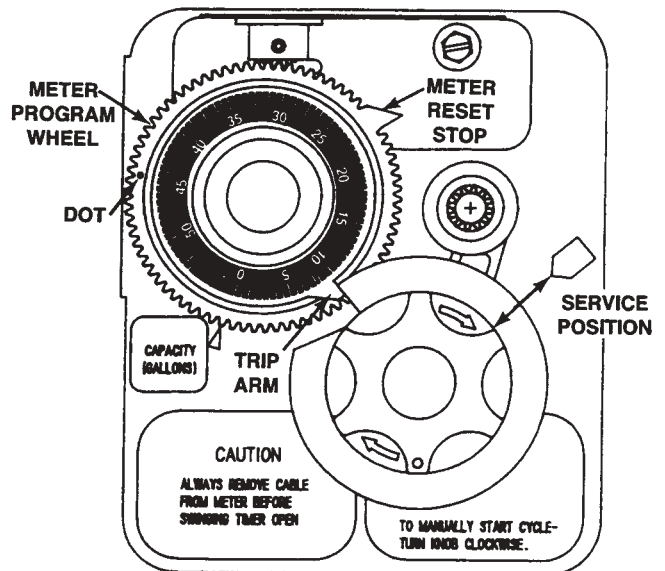

**FIG. 4**



# Installation

## Sanitizing Procedure

A water softener in daily use on a potable water supply generally requires no special attention other than keeping the salt tank filled. Occasionally, however, a unit may require sanitization under one of the following conditions:

- At start-up time.
- After standing idle for a week or more.
- On private supplies, the appearance of off-tastes and odors, particularly if musty or "rotten egg" (caused by harmless sulfate-reducing bacteria).

***Note:** If the water supply contains iron, regenerate the softener before sanitizing to remove iron from the resin.*

**CAUTION! HAZARD FROM TOXIC FUMES! CHLORINE BLEACH AND COMMON IRON CONTROL CHEMICALS MAY GENERATE TOXIC FUMES WHEN MIXED.**

- **IF THE UNIT USES CULLIGAN SOFNER-GARD® OR OTHER COMPOUNDS CONTAINING SODIUM HYDROSULFITE, SODIUM BISULFITE, OR ANY OTHER REDUCING AGENT, DISCONNECT THE DEVICE FEEDING THE CHEMICAL(S) AND MANUALLY REGENERATE THE UNIT BEFORE SANITIZING.**
- **DO NOT USE THIS PROCEDURE IF THE SOFTENER SALT CONTAINS IRON CONTROL ADDITIVES.**

1. Remove the brine tank cover.
2. Pour directly into the brine chamber 1/3 - 1/2 cup of common household bleach (5.25% sodium hypochlorite) for each cubic foot of resin in the tank. **Do not use lemon scented bleaches, or similar bleaches that contain perfumes.**
3. Manually start recharge. Allow the unit to complete the recharge cycle automatically.

If tastes and odors return frequently, even after sanitization, a continuous chlorination system may be needed. Send a water sample to a qualified laboratory for bacterial analysis.

## Analyzing the System

Analyzing the problem involves three basic steps:

1. Check the system in all cycle positions.
2. Compare the data to normal operating data.
3. Determine which component may cause the problem (troubleshooting).
4. If steps 1-3 did not reveal the problem, initiate a regeneration cycle and manually cycle the valve to brine draw (#2 position). Allow the unit to complete the brine draw cycle and observe how the system reacts.

Although it may be possible to solve a specific problem simply by changing a component, analyzing the entire system can reveal additional problems which would otherwise require extra service calls. "Parts changing" is not the same as service.

## Check the System

The following tools are needed to collect data:

1. Hardness, iron and chlorine test kits
2. Thermometer
3. Pressure gauge, 0-120 psi
4. 5-Gallon bucket and watch
5. Calculator

The customer can provide most data. By collecting data prior to a service call, a "first guess" about the cause of the problem can be made and the need for any special parts can be determined. If the problem is as simple as lack of salt in the brine tank, a service call may not be needed at all. At the end of Appendix A is a recommended system data sheet that will assist the troubleshoot process.

## Before Leaving the Installation Site

**Sanitizing the softener.** See sanitizing procedure on previous page.

**Ensure that the brine tank has water** to the level of the float. Add water to the tank with a hose or put the unit into a full recharge so that the brine refill cycle will fill the tank with the proper amount of water.

**The water heater will hold hard water for several days.** Advise the customer that the existing water volume in the tank will need to be used before the hot water is soft. If soft hot water is required immediately, refer to the water heater owner's manual for the proper method of draining the water heater.

**Explain the operation of the softener to the customer.** Make sure the customer knows that there will be new sounds associated with the recharging of the unit. Advise the customer to periodically check and replenish the salt supply.

**Clean up the unit and installation site,** removing any soldering, or pipe threading, residues from the equipment and surrounding area with a damp towel.

## Salt Supply, Usage & Service

Salt is the mineral used to “recharge” your water conditioner. A brine solution is automatically made up in the bottom of the salt storage container, the Culllex® resin beads in the mineral tank are flushed with the brine solution as a step in the recharging process.

Your Culligan Water Conditioner has been carefully designed to get the greatest amount of softening capacity from the salt it uses. Here is some pertinent information about salt usage, types and service.

### **Salt Economizer**

This control is set at the time of installation, and determines salt usage according to the water hardness, number of persons in the household, and water usage.

### **What Kind of Salt is Best**

All Culligan Water Conditioners are designed to use any water conditioner salt of good quality, including “rock”, “pellet”, “solar”, or “evaporated” types.

All rock salt, regardless of source, contains insoluble material which collects at the bottom of the salt storage tank and requires periodic clean-out.

If purified salt products are used, the salt storage compartment will require less frequent clean-out, but you must check more frequently for “bridging”.

Regardless of what type of salt is used, we recommend Culligan Brand Salt as suggested by your Culligan Dealer. He or she is the expert and can provide you with the best product for your Culligan Water Conditioner.

### **Automatic Salt Delivery Service**

Ask your Culligan Dealer for details about salt delivery service. You can have your salt supply replenished on a regular basis. Whether you have automatic delivery service or pick up salt from your Culligan Dealer, you will be getting quality salt packaged according to rigid Culligan specifications. Using Culligan Brand Salt will help assure continued efficiency and trouble-free operation of your water conditioner.

**SODIUM INFORMATION:** *“Water softeners using sodium chloride for regeneration add sodium to the water. Persons who are on sodium restricted diets should consider the added sodium as part of their overall sodium intake.”*

### Care and Cleaning of Your Water Conditioner

Following these simple precautions will help assure continued trouble-free service and keep your Culligan Water Conditioner looking like new for years.

1. Do not place heavy objects on top of the salt storage tank or timer cover.
2. Use only mild soap and warm water when cleaning the exterior of the conditioner. Never use harsh, abrasive cleaning compounds or those which contain acid, such as vinegar, bleach and similar products.
3. **Important: Protect your water conditioner and the entire drainline from freezing temperatures. DANGER: If your unit should freeze, do not attempt to disassemble it. Call your Culligan Dealer.**
4. **Important: Culligan water softeners are sold for use on potable water, only. If at any time the water becomes contaminated, such as during a “boil water” situation, the operation of the water softener should be discontinued until it is verified that the water is again potable. To do this, push the red knob on the back of the water softener against the barrel of the bypass valve. Then, call your Culligan dealer to have your system sanitized before it is placed back into service.**
5. Should service, adjustment or trouble-shooting information be needed which is not covered in the Owners Guide/Installation Supplement, call your Culligan Dealer.

**Note:** *Following the manufacturer’s instructions regarding operation, maintenance and replacement requirements, including replacement of filters if applicable, is essential for Culligan’s products to perform as advertised.*

If you have further questions, please call your local independently operated Culligan dealer. He or she will be glad to be of assistance to you.

# Care & Cleaning

## To Clean Out the Salt Storage Tank

A periodic clean-out of the Salt Storage Tank is necessary to keep your Culligan Water Conditioner at peak operating efficiency. Do it at least every 2 years when the salt supply is low. Follow these step-by-step procedures:

### Tools needed:

- Scoop
- Clean, bucket-size container
- Phillips-head screwdriver
- Garden hose
- Household scrub brush or sponge

1. Remove the salt storage tank cover and the cap from the brine valve chamber.
2. Lift the brine valve out of the brine valve chamber and set aside in an upright position.
3. If you'd like to save any clean, dry salt remaining in the tank, remove it and place it in a clean container.
4. Using the scoop, dig out and discard as much remaining salt, water and debris as possible.
5. Remove the brine valve chamber by removing the screws on either side of the salt tank.
6. Remove the salt plate at the bottom of the brine tank.
7. Lay the salt tank on its side and direct a brisk stream of water from your garden hose to its inside to rinse out all residue.
8. Using a household scrub brush and a mild soapy solution, clean the salt plate. This will complete the tank cleaning.
9. Stand salt tank upright. Replace the salt plate. Place brine valve chamber in position and affix with screws.
10. Insert the brine valve into the chamber and replace brine valve chamber cap.
11. Fill the salt storage tank with 4 to 6 inches of water.
12. Fill the tank with salt to within a few inches of the top.
13. Replace salt storage tank cover.

## When and How to Bypass Your Water Conditioner

Normally, all water except outside lines passes through the water conditioner. There are times when the water conditioner should be bypassed, using the push-button Bypass Valve, or a 3-way bypass valve. You should bypass:

1. If lines to outside faucets do not bypass the water conditioner, and you do not want to waste soft water on lawn sprinkling or other outside uses.
2. If you are going away on vacation and want to save salt by not having the unit recharge while you're away.

## Things to Check Before You Call For Service

If you unexpectedly experience hard water, make these simple checks before calling your Culligan dealer. One of the following conditions may be the reason for your interruption of service.

### Important

If any of the following conditions is found, the water conditioner should be manually recharged according to instructions on page 9 after you have corrected the problem.

### Power Supply

Check your power supply cord. Is it plugged fully into the electric outlet? Be certain that the outlet is not controlled by a wall switch which has been turned off. Reset conditioner to proper time of day and then plug in.

### Blown Fuse

Check the house fuse or circuit breaker panel. Replace a blown-out fuse or reset an open circuit breaker.

### Power Failure

Any interruption in your power supply or time changes - such as daylight savings - will disrupt your conditioner's recharge schedule by causing the timer to run off-schedule. Reset timer to proper time of day.

### Bypass Valves

Check to see if they are in the proper position. Cul-Flo-Valv<sup>®</sup> Bypass, if used, should be in the "Push for Service" position. If hand valves are used, see that inlet and outlet valve are opened and that the bypass valve is closed.

### No Water

If you aren't getting any water flow at all, make sure your water supply is working. Open a tap ahead of the conditioner (outside tap) to see if you have any water pressure. If you have water pressure, check the bypass valve. If it is in the Service position, put it into the bypass and call your Culligan dealer for service.

### Increased Usage

Guests, family additions, new water-using appliances, etc., all will result in more water usage and will require more capacity from your conditioner. You can reprogram your recharging schedule by following the directions on pages 9 and 10. Call your Culligan dealer for advice and save a service call.

### Salt Supply

Check it. Refill if necessary and wait approximately 4 hours for salt to dissolve before initiating a recharge cycle.

### Salt Bridging

Salt bridging occurs when a space is formed between the salt and the water underneath, preventing the salt from dissolving to make brine. No brine, no soft conditioned water!

High humidity and/or use of some brands of purified salt products may cause a salt bridge to form.

The best way to check and eliminate a salt bridging problem is to take a broom handle or similar instrument and make a mark 34 inches from the end. Then carefully begin to probe down through the salt with the instrument. Should an obstruction be found before the mark on your instrument reaches the rim of the salt storage tank, a salt bridge is likely to have formed. Continue to probe and break the salt bridge completely.



**Caution!** Do not force the implement past the mark as damage to the horizontal salt plate may occur.



# Performance Data Sheet

Culligan knows the more informed you are about your water treatment systems, the more confident you will be about its performance. It's because of this and more than sixty-five years of commitment to customer satisfaction that Culligan is providing this Performance Data Sheet to its customers.

**IMPORTANT NOTICE:** Read this Performance Data Sheet and compare the capabilities of this unit with your actual water treatment needs. It is recommended that before purchasing a water treatment unit, you have your water supply tested to determine your actual water treatment needs.

**MANUFACTURER:** Culligan International Company,  
One Culligan Parkway, Northbrook, IL 60062-6209 USA  
(847) 205-6000

**PRODUCT:** Culligan Soft-Minder Twin™ 60 Water Softener

**TESTING CONDITIONS & RESULTS:**

Flow Rate:	10.4 gpm	Capacity:	14,600 grains @ 3.0 lb. salt
Pressure:	30 - 40 psi		29,400 grains @ 9.0 lb. salt
Acidity:	Non-Corrosive		33,800 grains @ 15.0 lb. salt
Temperature:	68° (20°C)	Efficiency Rated Dosage†:	4,880 gr/lb
pH:	7.6		

**SOFTENER SPECIFICATIONS:**

Maximum Flow Rate:	10.4 gpm (xx Lpm)
Pressure Drop at Maximum Flow Rate:	15 psi (xx kPa)
Operating Temperature Range:	33 - 120°F (1 - 50°C)
Maximum Drain Flow Rate:	1.6 gpm (6.1 Lpm)
Working Pressure Range:	20 - 120 psi (140 - 860 kPa)
Operating Pressure Range (Canada):	20 - 90 psi (140 - 620 kPa)



The Culligan Soft-Minder Twin Water Softeners are tested and certified by WQA against WQA S-100 for the effective reduction of calcium and magnesium (hardness).

This softener is efficiency rated, it has a Demand Initiated Regeneration (D.I.R.) feature which complies with specific performance specifications intended to minimize the amount of regenerant brine and water used in their operation. The softener has a rated salt efficiency of not less than 3350 grains of total hardness exchange per pound of salt used (based on NaCl equivalency), and shall not deliver more salt than its listed rating. The efficiency is measured by a laboratory test described in NSF/ANSI Standard 44. This test represents the maximum possible efficiency that the system can achieve. Operational efficiency is the actual efficiency achieved after the system has been installed. Operational efficiency is typically less than the efficiency due to individual application factors including water hardness, water usage, and other contaminants that reduce the softener's capacity.

Refer to the Specifications, Familiarization and Warranty section of this Owner's Guide for more specific product information. To avoid contamination from improper handling and installation, your system should only be installed and serviced by your Culligan Man. Performance will vary based on local water conditions. The substances reduced by this system are not necessarily in your water.

Culligan water softeners are designed to work with any salt of good quality, although it is recommended that you ask your local Culligan Man for his suggestion on the best type and grade of salt to use in this softener.

**NOTICE:** This softener is not intended to be used for treating water that is microbiologically unsafe or of unknown quality without adequate disinfection before or after the system.

† The efficiency rated dosage is only valid at the 3 lb salt dosage for 9" models.

Buyer Signature \_\_\_\_\_ Date \_\_\_\_\_  
Seller Signature \_\_\_\_\_ Date \_\_\_\_\_

# Performance Data Sheet

Culligan knows the more informed you are about your water treatment systems, the more confident you will be about its performance. It's because of this and more than sixty-five years of commitment to customer satisfaction that Culligan is providing this Performance Data Sheet to its customers.

**IMPORTANT NOTICE:** Read this Performance Data Sheet and compare the capabilities of this unit with your actual water treatment needs. It is recommended that before purchasing a water treatment unit, you have your water supply tested to determine your actual water treatment needs.

**MANUFACTURER:** Culligan International Company,  
One Culligan Parkway, Northbrook, IL 60062-6209 USA  
(847) 205-6000

**PRODUCT:** Culligan Soft-Minder Twin™ 90 Water Softener

**TESTING CONDITIONS & RESULTS:**

Flow Rate:	10.4 gpm	Capacity:	21,900 grains @ 4.5 lb. salt
Pressure:	30 - 40 psi		44,100 grains @ 13.5 lb. salt
Acidity:	Non-Corrosive		50,700 grains @ 22.5 lb. salt
Temperature:	68° (20°C)	Efficiency Rated Dosage†:	4,880 gr/lb
pH:	7.6		

**SOFTENER SPECIFICATIONS:**

Maximum Flow Rate:	10.4 gpm (xx Lpm)
Pressure Drop at Maximum Flow Rate:	15 psi (xx kPa)
Operating Temperature Range:	33 - 120°F (1 - 50°C)
Maximum Drain Flow Rate:	1.6 gpm (6.1 Lpm)
Working Pressure Range:	20 - 120 psi (140 - 860 kPa)
Operating Pressure Range (Canada):	20 - 90 psi (140 - 620 kPa)



The Culligan Soft-Minder Twin Water Softeners are tested and certified by WQA against WQA S-100 for the effective reduction of calcium and magnesium (hardness).

This softener is efficiency rated, it has a Demand Initiated Regeneration (D.I.R.) feature which complies with specific performance specifications intended to minimize the amount of regenerant brine and water used in their operation. The softener has a rated salt efficiency of not less than 3350 grains of total hardness exchange per pound of salt used (based on NaCl equivalency), and shall not deliver more salt than its listed rating. The efficiency is measured by a laboratory test described in NSF/ANSI Standard 44. This test represents the maximum possible efficiency that the system can achieve. Operational efficiency is the actual efficiency achieved after the system has been installed. Operational efficiency is typically less than the efficiency due to individual application factors including water hardness, water usage, and other contaminants that reduce the softener's capacity.

Refer to the Specifications, Familiarization and Warranty section of this Owner's Guide for more specific product information. To avoid contamination from improper handling and installation, your system should only be installed and serviced by your Culligan Man. Performance will vary based on local water conditions. The substances reduced by this system are not necessarily in your water.

Culligan water softeners are designed to work with any salt of good quality, although it is recommended that you ask your local Culligan Man for his suggestion on the best type and grade of salt to use in this softener.

**NOTICE:** This softener is not intended to be used for treating water that is microbiologically unsafe or of unknown quality without adequate disinfection before or after the system.

† The efficiency rated dosage is only valid at the 4.5 lb salt dosage for 10" models.

Buyer Signature \_\_\_\_\_ Date \_\_\_\_\_  
Seller Signature \_\_\_\_\_ Date \_\_\_\_\_

# Records & Data

## Records and Data

### Important Data on Your Water Conditioner

It is advisable to have the salesperson or installer fill in the information below for your future reference. If this has not been done, please ask for it, as it is necessary if you contact your dealer.

### IDENTIFICATION

Model Name \_\_\_\_\_ Catalog No. \_\_\_\_\_

Control Model No. \_\_\_\_\_ Control Serial No. \_\_\_\_\_

Date of Installation \_\_\_\_\_ Tank Serial No. \_\_\_\_\_

### SETTINGS

Salt Setting \_\_\_\_\_ lbs.

Time of Recharge: \_\_\_\_\_ a.m. \_\_\_\_\_ p.m.

Gallons to signal \_\_\_\_\_ gallons

Number of people in household

\_\_\_\_\_

### WATER ANALYSIS

Total Hardness \_\_\_\_\_ (gpg) Total Iron \_\_\_\_\_ (ppm) pH (acidity) \_\_\_\_\_

Other

\_\_\_\_\_

\_\_\_\_\_

## Culligan Limited Warranty

### Culligan Soft-Minder Twin™ Automatic Water Conditioners

You have just purchased one of the finest water conditioners made. As an expression of our confidence in Culligan International Company products, your water conditioner is warranted to the original end-user, when installed in accordance with Culligan specifications, against defects in material and workmanship from the date of original installation, as follows:

<b>For a period of ONE YEAR</b>	<b>The entire conditioner</b>
<b>For a period of THREE YEARS</b>	<b>Soft-Minder® meter.</b>
<b>For a period of TEN YEARS</b>	<b>The control valve body, excluding internal parts</b>
	<b>The salt storage container, brine valve and all its component parts</b>
<b>For the LIFETIME of the original consumer purchaser</b>	<b>The Quadra-Hull™ conditioner tank and the Cullex® resin</b>

If a part described above is found defective within the specified period, you should notify your independently operated Culligan dealer and arrange a time during normal business hours for the dealer to inspect the water conditioner on your premises. Any part found defective within the terms of this warranty will be repaired or replaced by the dealer. You pay only freight from our factory and local dealer charges.

We are not responsible for damage caused by accident, fire, flood, freezing, Act of God, misuse, misapplication, neglect, oxidizing agents (such as chlorine, ozone, chloramines and other related components), alteration, installation or operation contrary to our printed instructions, or by the use of accessories or components which do not meet Culligan specifications, is not covered by this warranty. Refer to the specifications section in the Installation and Operating manual for application parameters.

Our product performance specifications are furnished with each water conditioning unit. TO THE EXTENT PERMITTED BY LAW, CULLIGAN DISCLAIMS ALL IMPLIED WARRANTIES, INCLUDING WITHOUT LIMITATION WARRANTIES OF MERCHANTABILITY AND FITNESS FOR PARTICULAR PURPOSE; TO THE EXTENT REQUIRED BY LAW, ANY SUCH IMPLIED WARRANTIES ARE LIMITED IN DURATION TO THE ONE-YEAR PERIOD SPECIFIED ABOVE FOR THE ENTIRE CONDITIONER. As a manufacturer, we do not know the characteristics of your water supply or the purpose for which you are purchasing a water conditioner. The quality of water supplies may vary seasonally or over a period of time, and your water usage rate may vary as well. Water characteristics can also differ considerably if your water conditioner is moved to a new location. For these reasons, we assume no liability for the determination of the proper equipment necessary to meet your requirements, and we do not authorize others to assume such obligations for us. Further, we assume no liability and extend no warranties, express or implied, for the use of this product with a non-potable water source. OUR OBLIGATIONS UNDER THIS WARRANTY ARE LIMITED TO THE REPAIR OR REPLACEMENT OF THE FAILED PARTS OF THE WATER CONDITIONER, AND WE ASSUME NO LIABILITY WHATSOEVER FOR DIRECT, INDIRECT, INCIDENTAL, CONSEQUENTIAL, SPECIAL, GENERAL, OR OTHER DAMAGES.

Some states do not allow the exclusion of implied warranties or limitations on how long an implied warranty lasts, so the above limitation may not apply to you. Similarly, some states do not allow the exclusion of incidental or consequential damages, so the above limitation or exclusion may not apply to you. This warranty gives you specific legal rights, and you may also have other rights which vary from state to state. Consult your telephone directory for your local independently operated Culligan dealer, or write Culligan International Company for warranty and service information.

**CULLIGAN INTERNATIONAL COMPANY**  
**One Culligan Parkway**  
**Northbrook, Illinois 60062**

# Promise

## **With Culligan You Get More Than a Quality Product**

### **You Get Your Water Expert, The Culligan Man**

We're here to provide you with fast, dependable service, making sure any problems you have are taken care of. The Culligan Man has been around for over sixty years, delivery dependable service all along. That's why people say "Hey, Culligan Man!"<sup>®</sup> Because we're the water experts. And that's who you want taking care of your water.

### **The Culligan Promise**

At Culligan, we understand that a water quality improvement system is an investment in your family's well-being. That's why our 1,350 independently operated dealers worldwide don't just sell products; they sell water quality you can count on. We stand behind our products with written limited warranties and our unequalled Culligan service. No matter where you live, you can depend on Culligan expertise to work for you — today and tomorrow.



**This Page Left Blank Intentionally**

# Parts List

## Control Valve

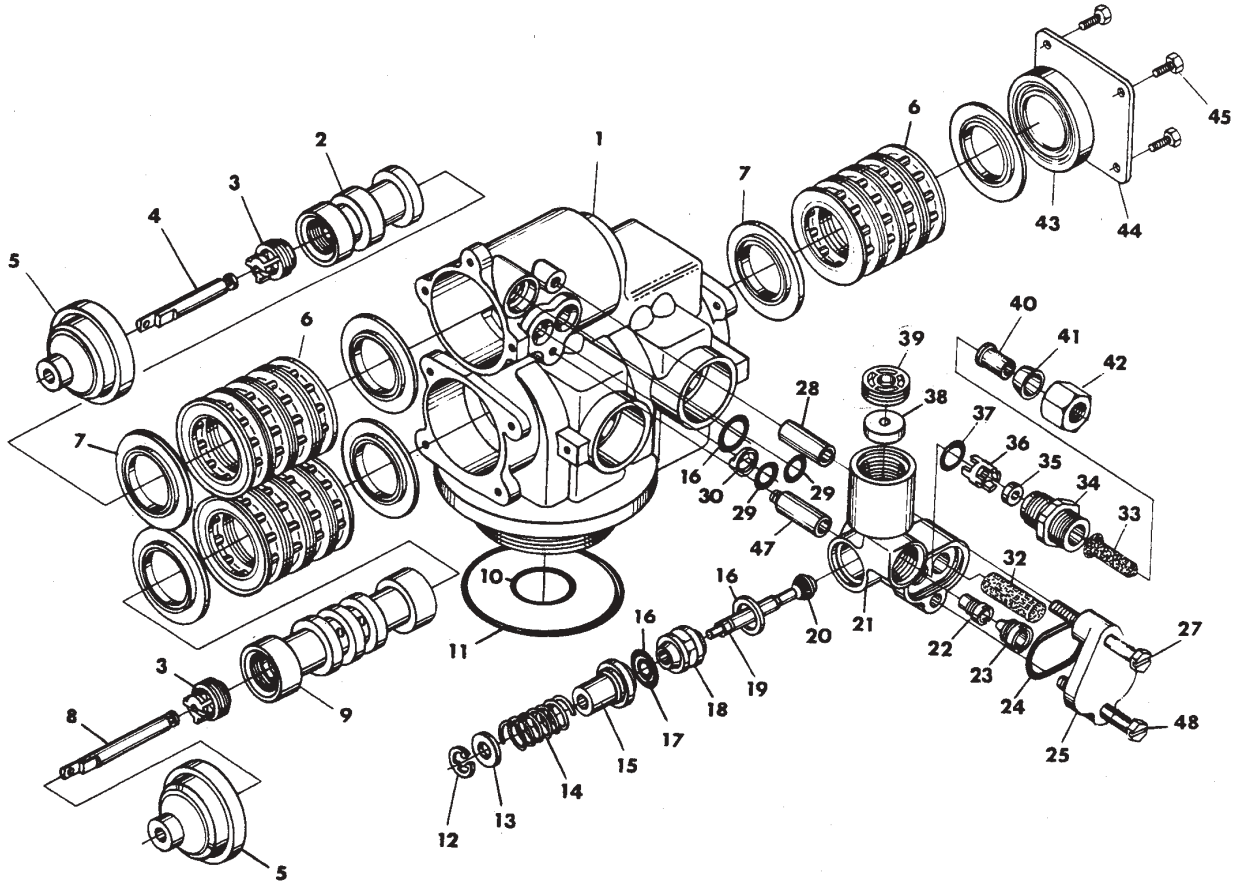



## Control Valve Parts List

Item No.	Part No.	Description	Qty.
	01-0028-90	Control Valve 3/4" NPSM	
1	01-0029-04	Valve Body, 2-1/2" - 8 ACME, Sept. 1993/Present	1
2	00-4020-07	Piston, Upper	1
3	00-4020-08	Piston Rod Retainer	2
4	00-4020-05	Piston Rod, Upper	1
5	00-4020-06	End Plug Assembly	2
6	00-4020-03	Spacer	12
7	00-4020-04	Seal	15
8	00-4020-01	Piston Rod, Lower	1
9	00-4020-02	Piston, Lower	1
10	00-4018-61	O-ring	1
11	00-4019-98	O-ring, Tank Top	1
12	00-4019-99	Retaining Ring	1
13	00-4019-96	Washer, Brine Valve	1
14	00-4019-97	Spring, Brine Valve	1
15	00-4019-94	Brine Valve Cap	1
16	00-4019-95	O-ring, Brine Spacer	3
17	00-4019-92	Quad Ring	1
19	00-4019-93	Brine Valve Stem	1
20	00-4019-90	Brine Valve Seat	1
22	00-4019-91	Throat, No. 0 (Red)	1
	00-4019-88	Throat, No. 1 (White)	1
23	00-4019-89	Nozzle, No. 0 (Red)	1
	00-4019-86	Nozzle, No. 1 (White)	1
24	00-4019-87	O-ring, Injector Cover	1
27	00-4019-84	Screw, Injector Mtg.	1
29	00-4019-85	O-ring, Injector	2
31	00-4019-82	O-ring, D.L.F.C.	1
32	00-4019-83	Injector Screen	1
33	00-4019-80	Screen, Brine Line	1
34	00-4019-81	Fitting, Brine Line	1
38	00-4019-78	Flow Control, 1.2 GPM	1
	00-4019-79	Flow Control, 1.5 GPM	1
48	00-4019-77	Screw, Injector Mtg.	1
*	01-0019-42	3/4" Bypass Valve	1
*	00-4400-09	Drain Elbow Adapter	1

\* Not shown

NOTE: Items 35, 36, 37, 40, 41 and 42 are not used.

For Items 18, 21, 25, 26, 28, 30, 39 and 43-47, call your local Culligan Dealer. To locate your nearest dealer, call 800-285-5442.

# Parts List

## Drive Assembly

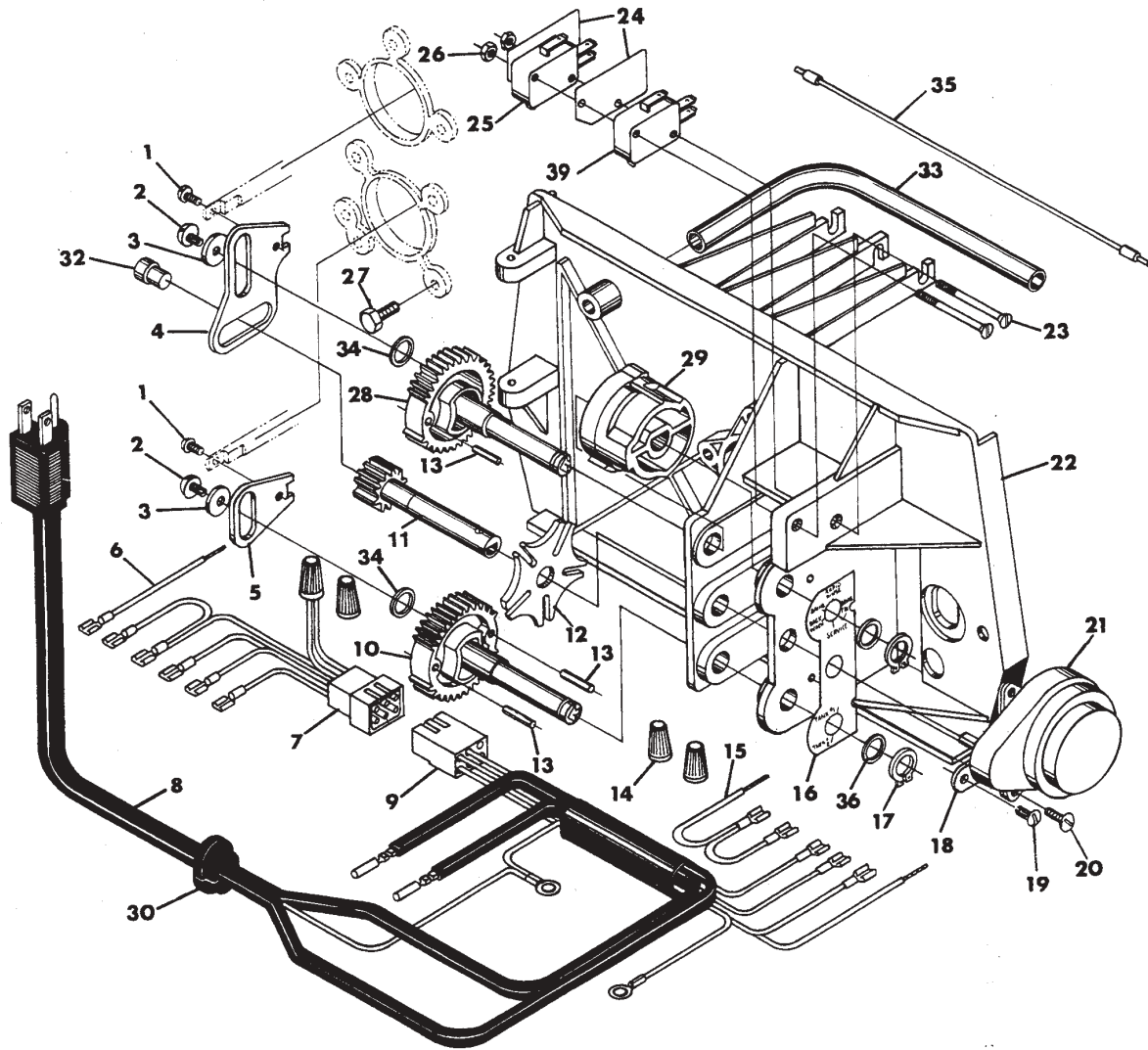

## Drive Assembly Parts List

Item No.	Part No.	Description	Qty.
1	00-4020-22	Screw, Piston Rod	2
2	00-4020-19	Screw, Piston Rod Link	2
3	00-4020-20	Washer	2
7	00-4020-17	Wiring Harness, Timer	1
8	00-4020-18	Power Cord	1
9	00-4020-15	Wiring Harness, Drive	1
17	00-4020-16	Retaining Ring	2
20	00-4020-13	Screw, Motor Mtg.	2
21	00-4020-14	Motor, 120V/60 Hz.	1
23	00-4020-11	Screw, Switch Mtg.	2
26	00-4018-72	Nut, Switch Mtg.	2
27	00-4020-12	Screw, Valve Mtg.	7
32	00-4020-09	Guide Pin	1
35	00-4018-24	Meter Cable	1

NOTE: For Items 4-6, 10-16, 18, 19, 22, 24, 25, 28-31, 33, 34 and 36, call your local Culligan Dealer. To locate your nearest dealer, call 800-285-5442.

# Parts List

## Timer Assembly Parts List

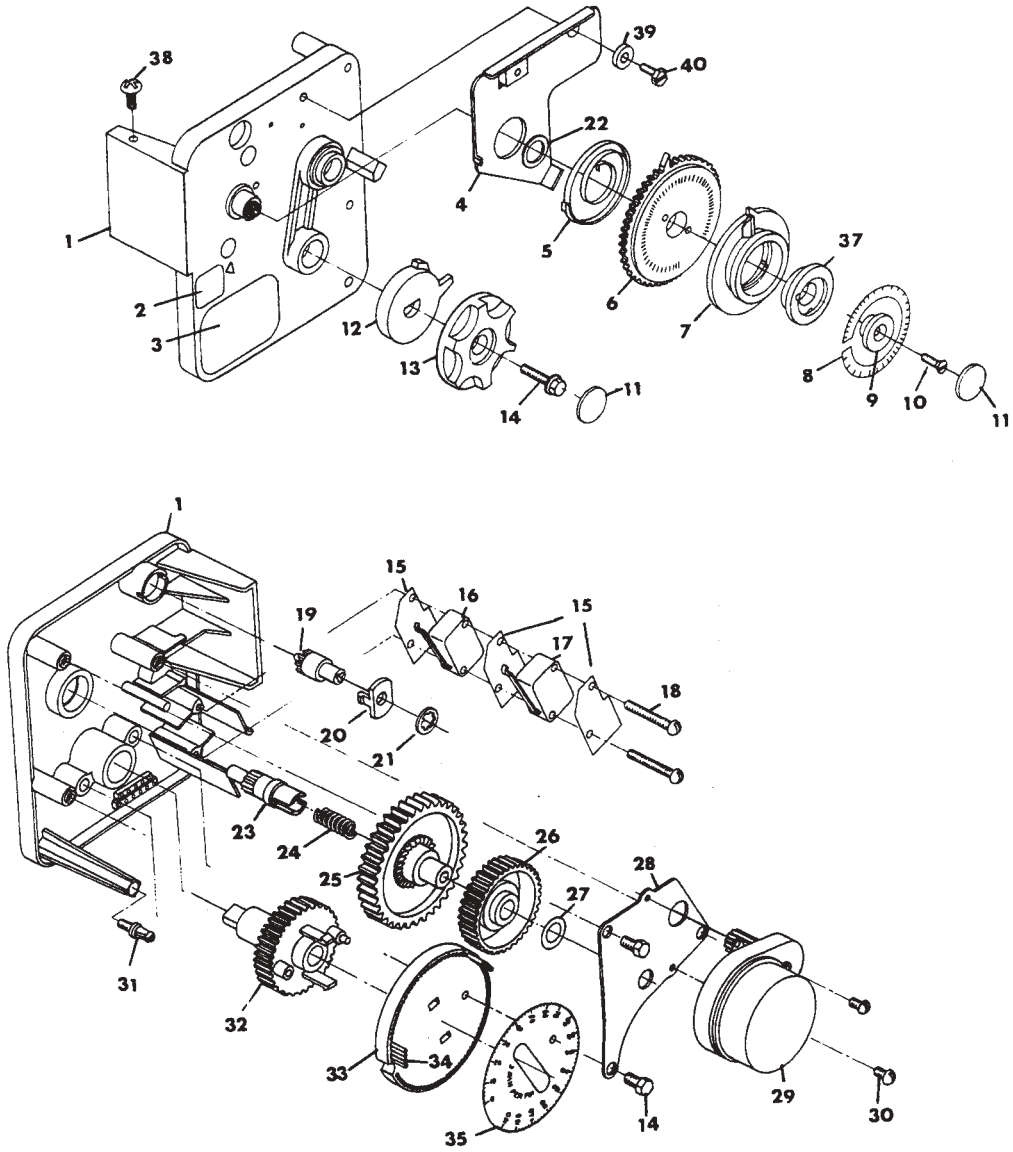

Item No.	Part No.	Description	Qty.
—	00-4020-21	Timer Assembly	1
16	00-4020-25	Switch	1
17	00-4020-26	Switch	1
19	00-4020-23	Drive Pinion	1
20	00-4020-24	Retainer	1
29	01-0019-41	Motor, 120V/60 Hz.	1
30	00-4018-23	Screw, Motor Mtg.	2

NOTE: For Items 1-15, 18, 21-28 and 31-40, call your local Culligan Dealer. To locate your nearest dealer, call 800-285-5442.

## Meter Assembly Parts List

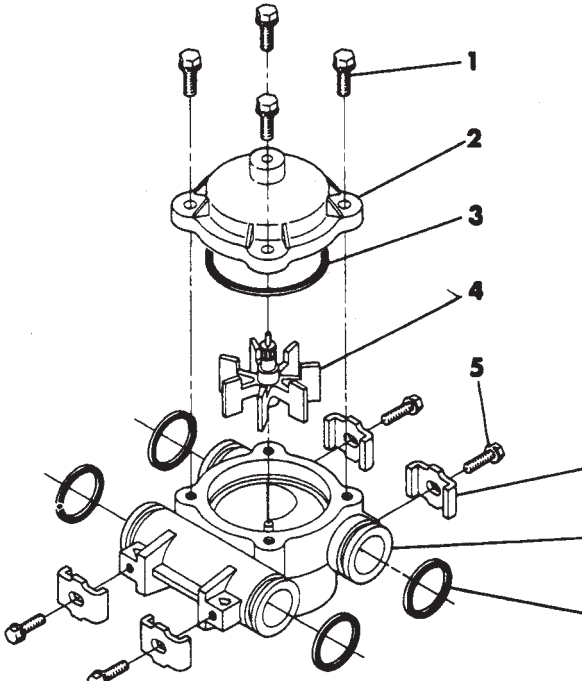

Item No.	Part No.	Description	Qty.
1	00-4019-71	Screw, Meter Cover	4
2	00-4019-68	Meter Cover Assembly	1
3	00-4019-69	O-ring, Meter Cover	1
4	00-4019-66	Impeller	1
5	00-4019-67	Screw, Clip	4
6	00-4019-72	Clip	4
7	00-4019-64	Meter Body	1
8	00-4019-65	O-ring, Meter Body	4
	01-0019-43	Meter Assembly	1

# Parts List

## Second Tank Adapter Parts List

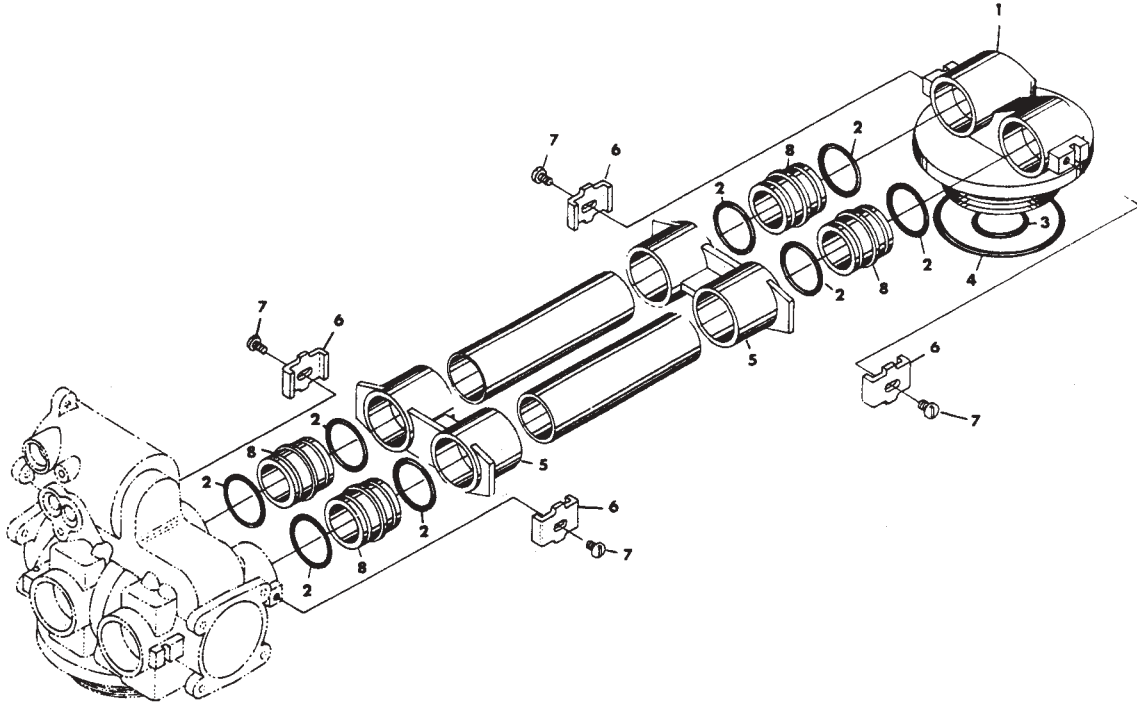

Item No.	Part No.	Description	Qty.
1	01-0052-21	Adapter, Tank #2, 2-1/2" -8 NPSM	
	01-0029-94	Adapter, Tank #2, 2-1/2" -8 ACME	
2	00-4019-74	O-ring, Coupling	8
5	00-4019-75	Yoke	2
6	00-4019-72	Clip	4
7	00-4019-73	Screw	4
8	00-4019-70	Coupling	4

NOTE: For Items 1, 3 and 4, call your local Culligan Dealer. To locate your nearest dealer, call 800-285-5442.

# Parts List

## Conditioner Tank Parts List

Item No.	Part No.	Description
—	01-0164-96	Tank, 9", Complete
—	01-0164-97	Tank, 10", Complete
—	01-0163-47	Replacement Tank, 9" (Less Cullex® and Manifold)
—	01-0163-48	Replacement Tank, 10" (Less Cullex and Manifold)
1	01-0165-03	Manifold, 9" Tank
—	01-0165-04	Manifold, 10" Tank

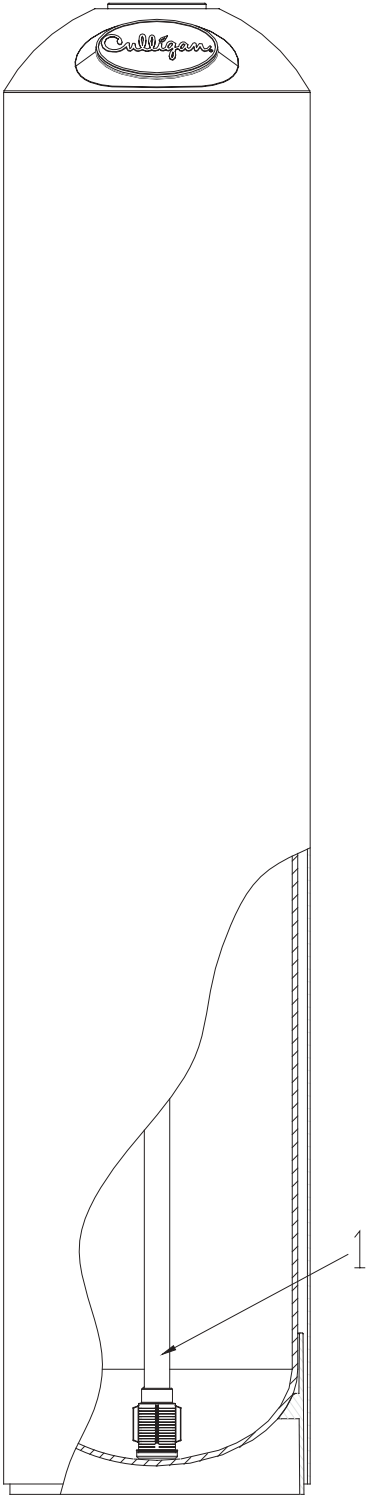



# Parts List

## Tank Assembly

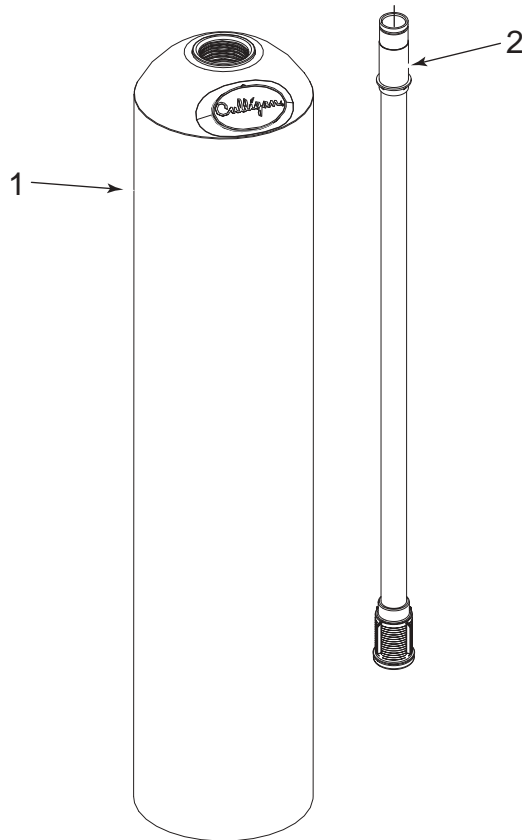

Item	Part Number	Description	Qty.
1	01-0164-96	Tank Assembly, 9" Aqua-Sensor®, Complete	
	01-0164-97	Tank Assembly, 10" Aqua-Sensor®, Complete	
	01-0163-51	Tank Assembly, 9" Soft-Minder®, Complete	
	01-0163-52	Tank Assembly, 10" Soft-Minder®, Complete	
	01-0163-49	Tank Replacement, 9"	
	01-0163-50	Tank Replacement, 10"	
3	01-0090-99	O-Ring, Manifold	1
4	01-0165-03	Outlet Manifold - 9" Tank	1
4	01-0165-04	Outlet Manifold - 10" Tank	1

# FILTER HOUSINGS

---

*A broad range of superior filter housings from the leader in water filtration.*



**PENTEK**<sup>™</sup>  
FILTRATION

*Pure Quality.*<sup>™</sup>

### THIRD GENERATION STANDARD FILTER HOUSINGS



**NSF**  
COMPONENT

The 3G Standard Caps and Sumps are Tested and Certified by NSF International.

- Integral bracket (IB) versions available.
- Available in 10" and 20", clear and opaque sumps.
- Buttress threads and uniform walls for easier cartridge change and improved strength.
- Accepts proprietary Seal-Safe™ double o-ring sealing cartridges as well as standard DOE cartridges.
- Caps available with differential pressure meter option (IB MM cap).
- Improved pressure-relief/bleed button option available.
- Leak-proof sealing with top-seated floating Buna-N o-ring.
- Clear housings offer on-site examination of cartridge.

This patent pending Third Generation (3G) design features integral brackets, 20" clear housings, and caps for differential pressure gauges. The patented 3G housing accepts standard double open end (DOE) and our Seal-Safe™ o-ring sealing cartridges. The new Seal-Safe™ o-ring design offers enhanced cartridge sealing for critical cartridge applications.

3G Standard Filter Housings are manufactured from a durable polypropylene or clear Styrene-Acrylonitrile (SAN) for excellent chemical compatibility. All are equipped with 3/4" NPT inlet and outlet ports.

#### Housing Specifications and Performance Data

Model	Maximum Dimensions	Initial ΔP (psi) @ Flow Rate (gpm)
#10 3G STD Blue or Clear MB	12¼" x 5½" (324 mm x 137 mm)	1 psi @ 10 gpm (0.07 bar @ 38 L/min)
#10 3G STD Blue or Clear IB/MM*	13¾" x 5½" (337 mm x 146 mm)	1 psi @ 10 gpm (0.07 bar @ 38 L/min)
#20 3G STD Blue or Clear MB	23" x 5½" (584 mm x 137 mm)	1 psi @ 10 gpm (0.07 bar @ 38 L/min)
#20 3G STD Blue or Clear IB/MM*	23½" x 5½" (597 mm x 146 mm)	1 psi @ 10 gpm (0.07 bar @ 38 L/min)

\* Height does not include meter. Add 1¼" for 143549 meter and 1/2" for 143550 meter.

#### Materials of Construction

- **Housing:** Polypropylene (Blue) or Styrene Acrylonitrile (Clear)
  - **Cap:** Reinforced Polypropylene
  - **Button Assembly:** 300-series Stainless Steel, polypropylene and EPDM
  - **O-Ring:** Buna-N
  - **Maximum Temperature:** 125°F (51.7°C)
  - **Maximum Pressure:** 125 psi (8.62 bar)
- CAUTION: Protect against freezing to prevent cracking of the filter and water leakage.

### THIRD GENERATION SLIM LINE® FILTER HOUSINGS



**NSF**  
COMPONENT

The 3G Slim Line® Caps and Sumps are Tested and Certified by NSF International.

- Choice of 1/4", 3/8", 1/2" NPT or John Guest Super Speedfit® Inlet/Outlet
- Integral bracket (IB) versions available.
- Available in clear and opaque.
- Buttress threads and uniform walls for easier cartridge change and improved strength.
- Caps available with differential pressure meter option (IB MM cap).
- Improved pressure-relief/bleed button option available.
- Leak-proof sealing with top-seated floating Buna-N o-ring.
- Clear housings offer on-site examination of cartridge.

This patent pending Third Generation (3G) design features integral brackets, John Guest Super Speedfit® quick connect fittings and caps for differential pressure gauges. The patented 3G housing accepts standard double open end (DOE).

3G Standard Filter Housings are manufactured from a durable polypropylene or clear Styrene-Acrylonitrile (SAN) for excellent chemical compatibility.

#### Housing Specifications and Performance Data

Model	Maximum Dimensions	Initial ΔP (psi) @ Flow Rate (gpm)
#10 3G SL Opaque or Clear 1/4" NPT MB	12½" x 4¾" (318 mm x 118 mm)	2 psi @ 3 gpm (0.14 bar @ 11 L/min)
#10 3G SL Opaque or Clear 3/8" NPT IB	13¾" x 5¼" (340 mm x 133 mm)	2 psi @ 5 gpm (0.14 bar @ 19 L/min)
#10 3G SL Opaque or Clear 1/2" NPT IB MM*	13¾" x 5¼" (340 mm x 133 mm)	2 psi @ 5 gpm (0.14 bar @ 19 L/min)
#10 3G SL Opaque or Clear 1/4" QC IB MM*	13¾" x 5¼" (340 mm x 133 mm)	2 psi @ 3 gpm (0.14 bar @ 19 L/min)
#10 3G SL Opaque or Clear 3/8" QC IB	13¾" x 5¼" (340 mm x 133 mm)	2 psi @ 5 gpm (0.14 bar @ 19 L/min)
#10 3G SL Opaque or Clear 1/2" QC MB	12½" x 4¾" (318 mm x 118 mm)	2 psi @ 5 gpm (0.14 bar @ 19 L/min)

MB = Mounting Boss Cap for mounting to bracket

\* Height does not include meter. Add 1¼" for 143549 meter and 1/2" for 143550 meter.

#### Materials of Construction

- **Housing:** Polypropylene (Opaque) or Styrene Acrylonitrile (Clear)
- **Cap:** Reinforced Polypropylene
- **Button Assembly:** 300-series Stainless Steel, polypropylene and EPDM
- **O-Ring:** Buna-N
- **Maximum Temperature:** 125°F (51.7°C)
- **Maximum Pressure:** 125 psi (8.62 bar)

John Guest Super Speedfit® is a registered trademark of John Guest USA, Inc.

## SLIM LINE® HOUSINGS



The 158005, 158006, 158114, 158115, 158128, 158129, 158131, 158149, 158195, 158196, 158204 and 158205 are Tested and Certified by NSF International under NSF/ANSI Standard 42 for material and structural integrity requirements only.

- Slim design reduces space required for installation without sacrificing capacity
- FDA grade
- Optional pressure-relief/bleed button on inlet side of cap
- Leak-proof sealing with top-seated Buna-N O-ring
- Available with clear and opaque sumps

Slim Line filter housings are available in either reinforced polypropylene or clear, Styrene-Acrylonitrile (SAN). The clear polypropylene housings are available in 5", 10", and 20" lengths while the SAN (clear) housings are available in 5" and 10" lengths. The reinforced polypropylene housing caps are available with 1/4", 3/8" or 1/2" NPT connections. Four bosses are molded into every cap for mounting purposes. Excellent for low-flow applications and when space and chemical compatibility are primary concerns.

### CLEAR SLIM LINE HOUSINGS

The clear Slim Line housings offer on-site examination of flow, performance and cartridge life. Manufactured of clear, Styrene-Acrylonitrile (SAN), the sumps are stress relieved for added clarity and strength.

### OPAQUE SLIM LINE HOUSINGS

Molded from rugged reinforced polypropylene, these housings are ideal for under-sink and countertop residential filtration, pre- and post-reverse osmosis filtration, recreational vehicle filtration, food service, humidifying systems and light commercial and industrial filtration.

#### Housing Specifications and Performance Data

Model	Maximum Dimensions	Initial ΔP (psi) @ Flow Rate (gpm)
#5 Clear	7-3/8" x 4-5/8" (187 mm x 118 mm)	1/4" NPT-2 psi @ 3 gpm (0.14 bar @ 11 L/min)
#10 Clear	12-1/8" x 4-5/8" (308 mm x 118 mm)	3/8" NPT-2 psi @ 5 gpm (0.14 bar @ 19 L/min)
#5 Opaque	7" x 4-3/8" (178 mm x 111 mm)	1/4" NPT-2 psi @ 3 gpm (0.14 bar @ 11 L/min)
#10 Opaque	11-3/4" x 4-3/8" (299 mm x 111 mm)	1/2" NPT-2 psi @ 5 gpm (0.14 bar @ 19 L/min)
#20 Opaque	21-7/8" x 4-3/8" (556 mm x 111 mm)	1/2" NPT-2 psi @ 5 gpm (0.14 bar @ 19 L/min)

#### Materials of Construction

- **Housing:** Styrene Acrylonitrile (Clear) and Polypropylene (Opaque)
- **Cap:** Reinforced Polypropylene
- **Button Assembly:** 300-series Stainless Steel, Polypropylene and EPDM
- **O-Ring:** Buna-N
- **Maximum Temperature:** 125°F (51.7°C)
- **Maximum Pressure:** 125 psi (8.62 bar)

## STANDARD HOUSINGS



The 150001, 150002, 150067, 150068, 150071, 150072, 150435 and 150436 are Tested and Certified by NSF International under NSF/ANSI Standard 42 for material and structural integrity requirements only.

MB=Mounting Boss Cap #10 Clear MB

- Ideal for a wide range of applications including residential, commercial and industrial
- Available in 10" and 20" lengths
- Optional pressure-relief/bleed button on inlet side of cap
- Thick walls for increased strength
- Leak-proof sealing with top-seated Buna-N O-ring
- Available with clear and opaque sumps

Standard filter housings are manufactured of a durable polypropylene or clear Styrene-Acrylonitrile (SAN). All are equipped with 3/4" NPT inlet and outlet ports.

Reinforced polypropylene housings have excellent chemical resistance and are ideal for many residential, commercial and industrial applications. Clear sumps are manufactured from a clear, Styrene-Acrylonitrile (SAN). They offer on-site examination of flow and have excellent chemical compatibility as well.

Standard filter housings are available in both 10" and 20" lengths and will accommodate a wide range of 2 1/2" and 2 3/8" diameter cartridges.

#### Housing Specifications and Performance Data

Model	Maximum Dimensions	Initial ΔP (psi) @ Flow Rate (gpm)
#10 Blue	12 1/4" x 5 1/2" (311 mm x 130 mm)	1 psi @ 10 gpm (0.1 bar @ 38 L/min)
#10 Clear	12 1/2" x 5 1/4" (321 mm x 133 mm)	1 psi @ 10 gpm (0.1 bar @ 38 L/min)
#20 Blue	22 3/8" x 5 1/2" (568 mm x 130 mm)	1 psi @ 10 gpm (0.1 bar @ 38 L/min)

#### Materials of Construction

- **Housing:** Polypropylene (Blue) or Styrene Acrylonitrile (Clear)
- **Cap:** Reinforced Polypropylene
- **Button Assembly:** 300-series Stainless Steel, Polypropylene and EPDM
- **O-Ring:** Buna-N
- **Maximum Temperature:** 125°F (51.7°C)
- **Maximum Pressure:** 125 psi (8.62 bar)

## VALVE-IN-HEAD HOUSINGS



The 150164 and 150172 are Tested and Certified by NSF International under NSF/ANSI Standard 42 for material and structural requirements only.

- Ideal for a wide range of applications including residential, commercial and industrial
- Available in 10" and 20" lengths
- Optional pressure-relief/bleed button on inlet side of cap
- Thick walls for increased strength
- Leak-proof sealing with top-seated Buna-N o-ring
- Available with clear and opaque sumps

Valve-in-Head housings incorporate the same rugged design and application features as our Standard 3/4" NPT housings.

The internal valve-in-head allows both inlet and outlet ports to be simultaneously shut-off with a half turn of the handle. This eliminates the need for external shut-off valves. Radial sealing O-rings and sealing surfaces are continuously cleaned each time the valve is used, ensuring leak-proof operation.

Valve-in-Head filter housings are available in both 10" and 20" lengths, will accommodate a wide range of 2 1/8" and 2 1/4" diameter cartridges and are available with either reinforced polypropylene or clear Styrene-Acrylonitrile (SAN) sumps.

### Housing Specifications and Performance Data

Model	Maximum Dimensions	Initial ΔP (psi) @ Flow Rate (gpm)
#10 VIH	12 1/2" x 5 1/2" (318 mm x 130 mm)	4 psi @ 8 gpm (0.3 bar @ 30 L/min)
#10 VIH Clear	12 7/8" x 5 1/4" (327 mm x 133 mm)	4 psi @ 8 gpm (0.3 bar @ 30 L/min)
#20 VIH	22 3/4" x 5 1/2" (575 mm x 130 mm)	4 psi @ 8 gpm (0.3 bar @ 30 L/min)

### Materials of Construction

- **Housing:** Polypropylene (Blue)  
Styrene Acrylonitrile (Clear)
- **Cap:** Reinforced Polypropylene
- **Button Assembly:** 300-series Stainless Steel, Polypropylene and EPDM
- **O-Ring:** Buna-N
- **Maximum Temperature:** 125°F (51.7°C)
- **Maximum Pressure:** 125 psi (8.62 bar)

## HIGH TEMPERATURE HOUSINGS



- Ideal for a wide range of industrial applications
- Excellent alternative to stainless and carbon steel vessels
- Durable glass-reinforced nylon construction

Constructed of glass-reinforced nylon, High Temperature filter housings are an economical alternative to stainless and carbon steel housings.

These 1/2" and 3/4" NPT housings can withstand temperatures up to a maximum of 160°F (71.1°C). Excellent chemical compatibility makes High Temperature housings an ideal choice for a wide variety of industrial applications including those involving organic solvents, sea water, alcohol, petroleum and vegetable oils. These housings should not be used with Ketones.

A 241 Viton® O-ring provides dependable sealing. Both 10" and 20" lengths are available to accommodate flow rates up to 20 gpm (76 L/min.).

### Housing Specifications and Performance Data

Model	Maximum Dimensions	Initial ΔP (psi) @ Flow Rate (gpm)
3/4" #10 HT	12 1/2" x 5 1/2" (308 mm x 130 mm)	<1 psi @ 8 gpm (< 0.1 bar @ 30 L/min)
3/4" #20 HT	22 3/4" x 5 1/2" (565 mm x 130 mm)	<1 psi @ 8 gpm (< 0.1 bar @ 30 L/min)
1/2" #10 HTSL	11 3/4" x 4 3/8" (298 mm x 111 mm)	5 psi @ 8 gpm (< 0.4 bar @ 30 L/min)
1/2" #20 HTSL	21 7/8" x 4 3/8" (556 mm x 111 mm)	5 psi @ 8 gpm (< 0.4 bar @ 30 L/min)

### Materials of Construction

- **Housing:** Glass-Reinforced Nylon
- **Cap:** Glass-Reinforced Nylon
- **O-Ring:** Viton®
- **Maximum Temperature:** 160°F (71.1°C) (High Temperature)
- **Maximum Pressure:** 125 psi (8.62 bar)



## BIG BLUE® HOUSINGS



The 150233, 150234, 150235, 150236, 150237, 150238, 150239, 150240, 150467 and 150469 are Tested and Certified by NSF International under NSF/ANSI Standard 42 for material and structural integrity requirements only.

- Large capacity housing suitable for high flow applications
- Available in 10" and 20" lengths
- Optional pressure-relief/bleed button on inlet side of cap
- Accepts 4½" diameter cartridges

Big Blue filter housings offer the versatility to meet all of your large-capacity filtration needs, including high-flow and heavy-sediment applications. The extra large housing allows for greater cartridge capacity, reducing the number of vessels required for high flow-rate applications. Sumps are constructed of durable reinforced polypropylene and are available in both 10" and 20" lengths.

The high-flow polypropylene (HFPP) cap is available with 3/4", 1" or 1½" NPT inlet and outlet ports. The ¼" internal port allows a greater volume of liquid to pass through the HFPP cap more rapidly.

Big Blue housings are compatible with a broad range of chemicals and are available with or without an optional pressure-relief button. They accept a wide variety of 4½" diameter cartridges in either 10" or 20" lengths.

### Housing Specifications and Performance Data

Model	Maximum Dimensions	Initial ΔP (psi) @ Flow Rate (gpm)
3/4" #10BB	13½" x 7¼" (333 mm x 184 mm)	2 psi @ 15 gpm (0.1 bar @ 57 L/min)
1" #10BB	13½" x 7¼" (333 mm x 184 mm)	1 psi @ 15 gpm (0.1 bar @ 57 L/min)
1½" #10BB	13½" x 7¼" (346 mm x 184 mm)	1 psi @ 20 gpm (0.1 bar @ 76 L/min)
3/4" #20BB	23¾" x 7¼" (594 mm x 184 mm)	2 psi @ 15 gpm (0.1 bar @ 57 L/min)
1" #20BB	23¾" x 7¼" (594 mm x 184 mm)	1 psi @ 15 gpm (0.1 bar @ 57 L/min)
1½" #20BB	23¾" x 7¼" (606 mm x 184 mm)	1 psi @ 20 gpm (0.1 bar @ 76 L/min)

### Materials of Construction

- **Housing:** Polypropylene
- **Cap:** Polypropylene (HFPP)
- **Button Assembly:** 300-series Stainless Steel, Polypropylene and EPDM
- **O-Ring:** Buna-N
- **Maximum Temperature:** 100°F (37.8°C)
- **Maximum Pressure:** #10BB – 100 psi (6.90 bar)  
#20BB – 90 psi (6.2 bar)

## ALL NATURAL HOUSINGS



- An economical solution to fluoropolymer, stainless steel or Teflon® housings
- Pure polypropylene components – no fillers, colorants, plasticizers or lubricants
- Ultra-smooth contact surfaces prevent bacterial adhesion and build-up
- Resists DI water and other inorganic solutions
- Resists stress cracking
- Viton® o-rings provide dependable sealing

All Natural filter housings help maintain high standards of purity and performance required in critical contamination control systems and processes. These housings can also be used for a variety of other applications where purity, quality, filtration and economy are required.

All housings have 3/4" (19 mm) NPT inlet and outlet threads. Some housings are available with plugged 1/4" (6.4 mm) NPT inlet, outlet and sump ports.

Compatible with most Pall, Millipore, Gelman, Brunswick, Sartorius, Filterite and Nuclepore membrane cartridges.

### Housing Specifications and Performance Data

Model	Cartridge Sealing	Maximum Dimensions	Initial ΔP (psi) @ Flow Rate (gpm)
3/4" #10	DOE <sup>1</sup>	12½" x 5½" (320 mm x 180 mm)	3 psi @ 7 gpm (0.2 bar @ 26.5 L/min)
3/4" #12	222 <sup>2</sup>	15¾" x 5½" (390 mm x 180 mm)	3 psi @ 7 gpm (0.2 bar @ 26.5 L/min)
3/4" #20	DOE <sup>1</sup>	23¾" x 5½" (590 mm x 180 mm)	3 psi @ 7 gpm (0.2 bar @ 26.5 L/min)

<sup>1</sup>Double Open End    <sup>2</sup>222 o-ring sealing

### Materials of Construction

- **Housing:** All Natural Polypropylene
- **Cap:** All Natural Polypropylene
- **O-Ring:** Viton®
- **Maximum Temperature:** 100°F (37.8°C)
- **Maximum Pressure:** 100 psi (6.90 bar)

## BAG VESSEL HOUSINGS



- *Lightweight corrosion-resistant polypropylene construction gives your strength without weight*
- *Available in 1" and 1½" NPT sizes*
- *Comes complete with gauge, wrench and 3/8" drain valve*
- *Choice of 10" and 20" housings*
- *Light enough to be portable*

Pentek's standard bag vessel assemblies keep your system on stream longer by reducing bag filter change time. The single large Acme thread closure ensures quick opening and positive sealing.

All PBH Series vessels come complete with gauge, wrench and 3/8" drain valve.

PBH Series vessel assemblies are made of lightweight corrosion-resistant polypropylene to give you all the strength you need without the weight.

Bag vessel assemblies are economically priced, allowing you to install a duplex system for totally uninterrupted flow rates.

### Housing Specifications and Performance Data

Model (Inlet/Outlet)	Maximum Dimensions	Initial ΔP (psi) @ Flow Rate (gpm)	Maximum Pressure
PBH-410 1" NPT	13¾" x 7¼" (333mm x 184mm)	1 psi @ 15 gpm (.07 bar @ 57 L/min)	100 psi (6.90 bar)
PBH-410 1½" NPT	13¾" x 7¼" (346mm x 184mm)	1 psi @ 20 gpm (.07 bar @ 76 L/min)	100 psi (6.90 bar)
PBH-420 1" NPT	23¾" x 7¼" (594mm x 184mm)	1 psi @ 15 gpm (.07 bar @ 57 L/min)	90 psi (6.2 bar)
PBH-420 1½" NPT	23¾" x 7¼" (606mm x 184mm)	1 psi @ 20 gpm (.07 bar @ 76 L/min)	90 psi (6.2 bar)

### Materials of Construction

- *Housing:* Polypropylene
- *Cap:* Polypropylene
- *Gauge:* Bismuth Brass (lead free)
- *Vent Plug:* Polypropylene
- *Drain Plug:* High Density Polypropylene
- *Ball Valve:* PVC/Buna-N Seals
- *Basket:* Polypropylene
- *O-Ring and Gaskets:* Buna-N
- *Maximum Temperature:* 100°F (37.8°C)

## ST SERIES STAINLESS STEEL HOUSINGS



- *Heavy-duty units for smaller filtration systems and point-of-use applications*
- *Brushed 304 stainless steel sump with a cast-brass/nickel-plated head*
- *Ideal for high pressure/hot water applications*
- *Accepts complete range of standard double open end (DOE) cartridges*

ST Series stainless steel filter housings effectively provide heavy-duty filtration for smaller filtration systems and point-of-use applications. Supplying flow rates of up to 20 gpm (76 L/min.) at a maximum water temperature of 300°F (149°C), ST Series housings are ideal for hot water and high-pressure applications not suited for plastic housings. The brushed 304 stainless steel sumps are available with either a pipe plug or pet-cock in the bottom for draining. Heads are manufactured from nickel-plated cast-brass. All housings have 3/4" inlet and outlet threads.

ST Series housings are easy to install and maintain. They are compatible with a complete range of filter cartridges, adding to their versatility.

### Housing Specifications and Performance Data

Model	Dimensions	Recommended Flow Rates	Maximum Pressure
ST-1	12¾" x 4¾" (327 mm x 105 mm)	10 gpm (38 L/min)	250 psi (17.2 bar)
ST-2	22¾" x 4¾" (578 mm x 105 mm)	15 gpm (57 L/min)	250 psi (17.2 bar)
ST-3	32¾" x 4¾" (822 mm x 105 mm)	20 gpm (76 L/min)	250 psi (17.2 bar)

- *Maximum cartridge diameter 3" (76 mm).*
- *Will not accept model GAC, CC, CGAC, TSGAC, WS, PCF or PCC series cartridges.*

### Materials of Construction

- *Housing:* Brushed 304 Stainless Steel
- *Head:* Brass/Nickel Plated
- *Maximum Temperature:* 300°F (149°C)
- *Gaskets:* Buna-N, cellulose fiber (Nut)

*NOTE: Not recommended for applications with TDS or chlorides >1000ppm and/or pH <5.0. Use of this product in these conditions will void the limited warranty. Consult factory for product modifications for these conditions.*



## ST-BC SERIES STAINLESS STEEL HOUSINGS



- Heavy-duty units for large-scale commercial/industrial applications
- Brushed 304 stainless steel construction with a gray-silver epoxy finish
- Ideal for high-temperature applications
- Accepts complete range of standard double open end (DOE) cartridges

ST-BC Series stainless steel filter housings offer a variety of solutions for your large-scale, heavy-duty filtration needs. Simple to install and maintain, these housings are ideal for schools, restaurants, farms, institutions and industrial use. Holding from four to 20 cartridges, ST-BC Series housings provide flow rates from 28 - 125 gpm (106 - 473 L/min).

All housings have 2" NPT inlet and outlet threads and are constructed of 304 stainless steel with a gray-silver epoxy finish. They include drains on both the "clean" and "dirty" sides of the sump.

ST-BC Series housings are compatible with a complete range of filter cartridges, adding to their versatility.

### Housing Specifications and Performance Data

Model	Number of Cartridges, Dimensions of Cartridge	Recommended Flow Rates	Maximum Pressure
ST-BC-4	4-3" x 9 $\frac{3}{4}$ " or 10" (76 mm x 248 or 254 mm)	28 gpm (106 L/min)	125 psi (8.62 bar)
ST-BC-8	8-3" x 9 $\frac{3}{4}$ " or 10" (76 mm x 248 or 254 mm)	56 gpm (212 L/min)	125 psi (8.62 bar)
ST-BC-12	12-3" x 9 $\frac{3}{4}$ " or 10" (76 mm x 248 or 254 mm)	84 gpm (318 L/min)	125 psi (8.62 bar)
ST-BC-16	16-3" x 9 $\frac{3}{4}$ " or 10" (76 mm x 248 or 254 mm)	110 gpm (416 L/min)	125 psi (8.62 bar)
ST-BC-20	20-2 $\frac{1}{2}$ " x 9 $\frac{3}{4}$ " or 10" (64 mm x 248 or 254 mm)	125 gpm (473 L/min)	125 psi (8.62 bar)

- Will not accept model GAC, CC, CGAC, TSGAC, WS, PCF or PCC series cartridges.

### Materials of Construction

- **Housing:** Brushed 304 Stainless Steel
- **Finish:** Epoxy
- **Maximum Temperature:** 300°F (149°C)
- **Sealing Gasket:** Buna-N

**NOTE:** Not recommended for applications with TDS or chlorides >1000ppm and/or pH <5.0. Use of this product in these conditions will void the limited warranty. Consult factory for product modifications for these conditions.

## ACCESSORIES

### MOUNTING BRACKETS

**For Big Blue® Housings** — This stainless steel bracket is made for Big Blue filters only. Kit includes bracket and screws.

**For Mounting Caps with Bosses** — The MC-1A bracket is made for 3/4" (19 mm) housings with bosses only. Constructed of zinc-plated steel. Kit includes bracket and screws.

**For 3/4" Housings** — The UB-1 bracket is made for 3/4" (19 mm) inlet/outlet housings only. Constructed of zinc-plated steel. Kit includes bracket and screws.

**For Slim-Line® housings (1/4", 3/8" and 1/2")** — This bracket is manufactured for 1/2" (12.7 mm), 3/8" (9.5 mm) and 1/4" (6.4 mm) inlet/outlet housings only. Constructed of zinc-plated steel. Kit includes bracket and screws.

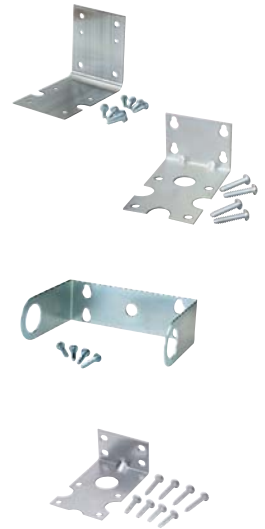

### SYSTEM MOUNTING BRACKETS

For Slim Line® and Big Blue® Housings



### SPANNER WRENCHES

Use to loosen sump when changing cartridges.

**SW-1: Plastic** — for Slim Line 1/4", 3/8" and 1/2" housings.

**SW-2: Plastic** — for 3/4" standard housings.

**SW-3: Plastic** — for 3/4", 1" and 1 $\frac{1}{2}$ " #10 Big Blue housings.

**SW-4: Plastic** — for 1" and 1 $\frac{1}{2}$ " #20 Big Blue housings.



PRESSURE/FLOW	NET PRESSURE DROP - psi (bar) @ FLOW RATE - gpm (L/min)																
MODEL NUMBER	1 (.4)	3 (11)	5 (19)	8 (30)	10 (38)	15 (57)	20 (76)	25 (95)	30 (114)	35 (132)	40 (151)	50 (189)	60 (227)	70 (265)	80 (303)	90 (341)	100 (379)
<b>1/4" Slim Line® &amp; 3G</b>	<1 (.1)	2 (.3)	4 (.7)	10 (1.7)	15 (2.4)												
<b>3/8" Slim Line® &amp; 3G</b>	<1 (.1)	<1 (.1)	2 (.3)	5 (.8)	7 (1.1)												
<b>1/2" Slim Line® &amp; 3G</b>	<1 (.1)	<1 (.1)	2 (.3)	5 (.8)	7 (1.1)												
<b>3/4" Standard &amp; 3G</b>	<1 (.1)	<1 (.1)	<1 (.1)	<1 (.1)	1 (.1)	2 (.3)	3 (.5)										
<b>3/4" V-I-H</b>	<1 (.1)	1 (.1)	2 (.3)	4 (.7)	7 (1.1)	16 (2.4)											
<b>Big Blue® HFPP 1"</b>	<1 (.1)	<1 (.1)	<1 (.1)	<1 (.1)	1 (.1)	1 (.1)	2 (.3)	3 (.5)	4 (.7)	5 (.8)	7 (1.1)	11 (1.6)	16 (2.3)				
<b>Big Blue® HFPP 1-1/2"</b>	<1 (.1)	<1 (.1)	<1 (.1)	<1 (.1)	<1 (.1)	1 (.1)	1 (.1)	2 (.3)	2 (.3)	3 (.5)	4 (.6)	7 (1.0)	10 (1.4)	13 (1.9)			

NOTE: The pressure drop values listed for flow rates higher than 10 gpm were extrapolated from curves, except in the case of Big Blue housings. All tests were performed on empty housings (no cartridges).  
CAUTION: Do not use with water that is microbiologically unsafe or of unknown quality without adequate disinfection before or after the unit.

### CHEMICAL COMPATIBILITY CHART

Chemical	300 Series Stainless Viton F-60 Silicone Buna-N Delrin ABS GF Nylon GF SAN Polypropylene TF % Concentration ** Temperature (F) **														
	125	50	A	A	D	A	D	C	-	C	-				
Acetic Acid	125	50	A	A	D	A	D	C	-	C	-				
Acetone	125	100	A	D	B	D	B	D	B	D	A				
Ammonium Compounds	125	100*	A	A	A*	A	B	A	B	A	C				
Ammonium Hydroxide	125	10	A	A	A	A	D	A	-	A	C				
Beer	125	ANY	A	A	D	B	A	D	C	A	A				
Benzene	72	100	B	D	A	D	B	D	-	A	B				
Calcium Compounds	125	ANY*	A	A	A	A	A	A	C	A	B/C				
Calcium Hypochlorite	68	20	A	-	D	-	D	B	C	A	D				
Citric Acid	125	10	A	A	C	B	A	D	C	A	-				
Cottonseed Oil	125	-	A	A	A	B	A	A	-	A	B				
Detergents	125	2	A	A	A	A	A	A	-	A	-				
Ethyl Alcohol	125	96	A	B	A	B	A	A	B	A	-				
Freon	68	25	B	<sup>12</sup> / <sub>22</sub>	A	<sup>12</sup> / <sub>22</sub>	D	<sup>12</sup> / <sub>10</sub>	D	<sup>12</sup> / <sub>10</sub>	<sup>11</sup> / <sub>ONLY</sub>				
Fruit Juices	125	-	A	A	A	A	A	A	-	A	A				
Gasoline	125	100	C	A	A	D	B	A	D	A	A				
Glucose	125	20	A	A	A	A	A	A	B	A	A				
Glycerin	125	100	A	A	A	B	A	A	B	A	A				
Glycol	125	-	A	D	-	D	A	A	-	A	-				
Hexane	125	100	C	-	A	D	D	A	B	A	A				
Hydrochloric Acid	125	20	A	A	D	B	D	C	-	A	-				
Hydrofluoric Acid	68	40	A	-	D	A	D	D	-	A	-				

Chemical	300 Series Stainless Viton F-60 Silicone Buna-N Delrin ABS GF Nylon GF SAN Polypropylene TF % Concentration ** Temperature (F) **														
	68	30	A	-	D	-	D	D	-	A	-				
Hydrogen Peroxide	68	30	A	-	D	-	D	D	-	A	-				
Inks	125	-	A	B	A	B	A	A	-	A	A				
Ketones	68	-	D	D	B	-	C	D	-	D	A				
Lubricating Oils	125	100	C	A	A	B	A	A	C	A	A				
Mercury	125	100	A	-	A	-	A	A	-	A	A				
Methyl Alcohol	125	100	A	D	A	D	A	B	-	C	-				
Mineral Oil	100	100	B	A	A	A	A	A	-	A	A				
Naphthalene	125	100	A	B	A	C	D	B	D	A	A				
Nitric Acid	68	10	A	B	D	C	D	D	-	A	A				
Olive Oil	125	100	A	A	A	A	A	A	C	A	A				
Plating Solutions	125	-	A*	-	AD*	-	*	A*	D	A	-				
Sodium Compounds	125	ANY	A	A	A/C*	C	*	A	C	A	B				
Sodium Hypochlorite	100	5	A	A	A	B	A	A	C	A	B				
Sugar & Syrups	125	-	A	-	A	B	A	A	A	A	A				
Sulfuric Acid	68	25	A	A	D	B	D	C	-	A	-				
Toluene	100	-	D	D	A	D	D	D	D	C	A				
Water (hot)	200	100	-	-	A	-	-	C	A	B	A				
DI Water	125	100	B	A	A	A	A	A	A	A	-				
Sea Water	125	100	A	B	A	A	C	A	-	A	-				
Whiskey/Wines	125	-	A	A	A	A	A	A	-	A	A				
Xylene	100	100	C	D	A	D	D	D	D	A	A				

A = Negligible Effect  
B = Limited Absorption Attack  
C = Extensive Absorption and/or Rapid Permeation  
D = Extensive Attack

\* = Consult Factory for Specific Compound  
\*\* = Maximum  
TF = Talc Filled  
GF = Glass Filled

NOTICE: We cannot anticipate all conditions under which this information and our products, or the products of other manufacturers in combination with our products, may be used. We accept no responsibility for results obtained by the application of this information or the safety and suitability of our products, either alone or in combination. Users are advised to make their own tests to determine the safety and suitability of each product or product combination for their own purposes and applications. Unless otherwise agreed in writing, or previously tested by USFilter on specific applications, we sell the product without warranty against chemicals listed above. Buyers and users assume all responsibility for liability performance or damage.



502 Indiana Avenue • P.O. Box 1047 • Sheboygan, Wisconsin 53082-1047  
Customer Service: 800-645-0267 • Fax: 888-203-7361 • supportspecialist@pentekfiltration.com  
International: 920-457-9435 • Fax: 920-457-2417 • international@pentekfiltration.com



DGD SERIES  
CARTRIDGES



DGD-2501  
DGD-5005  
DGD-7525

DGD-2501-20  
DGD-5005-20  
DGD-7525-20

## DGD SERIES DUAL-GRADIENT DENSITY CARTRIDGES

- **Manufactured from 100% pure polypropylene**
- **Designed for purity and chemical compatibility**
- **Two separate gradient density layers enhance cartridge performance**
- **Three times the dirt-holding capacity of similar sized sediment cartridges**

DGD Series cartridges are manufactured from 100% pure polypropylene and are sized for use in our Big Blue® filter housings.

DGD Series cartridges are designed for purity and will not impart taste, odor or color to the liquid being filtered. Additionally, the polypropylene construction provides superior chemical resistance and is not prone to bacterial attack.

The DGD Series advanced design combines selective “final filtration” with appropriate “pre-filtration” to achieve up to three times the dirt-holding capacity of similar size

sediment cartridges and many more times that of standard spun or string-wound cartridges. This performance enhancement is achieved by combining two separate gradient layers in one filter.

The larger diameter of the pre-filter reduces the particle load to the post filter, allowing it to operate at higher velocities. The effective filter depth is increased to a full 233% of standard spun-polypropylene or string-wound filters. This increased depth provides for very high particulate reduction efficiencies and added loading capacity.

The unique design and performance characteristics of the DGD Series cartridges make them an excellent choice for all residential, rural, municipal and commercial applications.



# DGD SERIES

## Dual-Gradient Density Cartridges

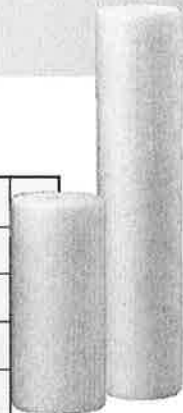
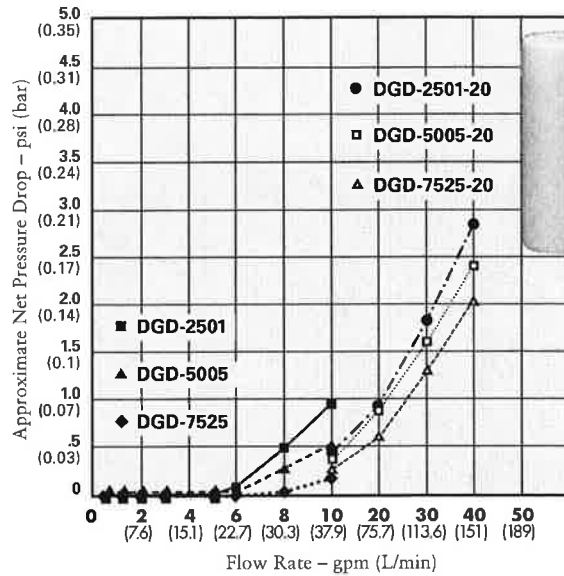
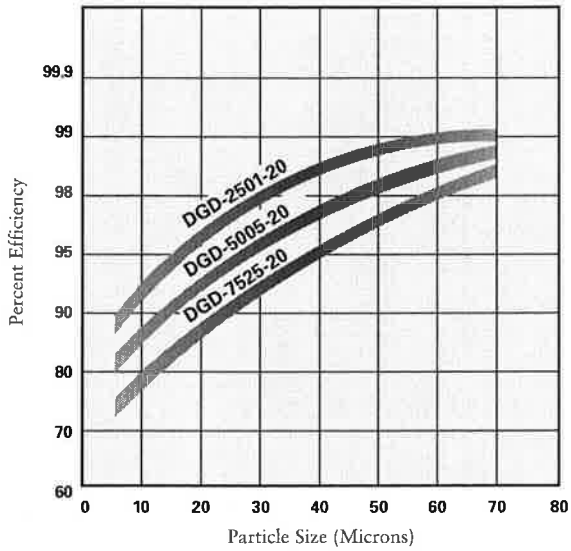

Tested and Certified by NSF International to NSF/ANSI Standard 42 for material requirements only.

### Cartridge Specifications and Performance Data

Model	Maximum Dimensions	Micron Rating* (Nominal)	Initial ΔP (psi) @ Flow Rate (gpm)
DGD-2501	4-1/2" x 10" (114 mm x 254 mm)	Pre-filter: 25 Post Filter: 1	<1 psi @ 10 gpm (<0.1 bar @ 38 L/min)
DGD-2501-20	4-1/2" x 20" (114 mm x 508 mm)	Pre-filter: 25 Post Filter: 1	<1 psi @ 20 gpm (<0.1 bar @ 76 L/min)
DGD-5005	4-1/2" x 10" (114 mm x 254 mm)	Pre-filter: 50 Post Filter: 5	<1 psi @ 10 gpm (<0.1 bar @ 38 L/min)
DGD-5005-20	4-1/2" x 20" (114 mm x 508 mm)	Pre-filter: 50 Post Filter: 5	<1 psi @ 20 gpm (<0.1 bar @ 76 L/min)
DGD-7525	4-1/2" x 10" (114 mm x 254 mm)	Pre-filter: 75 Post Filter: 25	<1 psi @ 10 gpm (<0.1 bar @ 38 L/min)
DGD-7525-20	4-1/2" x 20" (114 mm x 508 mm)	Pre-filter: 75 Post Filter: 25	<1 psi @ 20 gpm (<0.1 bar @ 76 L/min)

\* Based on manufacturer's internal testing

### Materials of Construction

- Filter Media: Polypropylene
- Temperature Rating: 40°F to 145°F (4.4°C to 62.8°C)

WARNING: Do not use with water that is microbiologically unsafe or of unknown quality without adequate disinfection before or after the system.



Installation and  
Operating  
Instructions  
with Parts List

**CULLIGAN® AQUADA  
ULTRAVIOLET  
WATER CONDITIONER  
MODELS FROM 2002**

**MAXIMA** NSF Class A Certified

- **M1**
- **M2**
- **M4**
- **M7**

*Culligan®*

***Attention Culligan Customer:***

The installation, service and maintenance of this equipment should be rendered by a qualified and trained service technician. Your local independently operated Culligan dealer employs trained service and maintenance personnel who are experienced in the installation, function and repair of Culligan equipment. This publication is written specifically for these individuals and is intended for their use.

We encourage Culligan users to learn about Culligan products, but we believe that product knowledge is best obtained by consulting with your Culligan dealer. Untrained individuals who use this manual assume the risk of any resulting property damage or personal injury.



**WARNING - PRIOR TO SERVICING EQUIPMENT, DISCONNECT POWER SUPPLY TO PREVENT ELECTRICAL SHOCK.**



**WARNING - IF INCORRECTLY INSTALLED, OPERATED OR MAINTAINED, THIS PRODUCT CAN CAUSE SEVERE INJURY. THOSE WHO INSTALL, OPERATE, OR MAINTAIN THIS PRODUCT SHOULD BE TRAINED IN ITS PROPER USE, WARNED OF ITS DANGERS, AND SHOULD READ THE ENTIRE MANUAL BEFORE ATTEMPTING TO INSTALL, OPERATE OR MAINTAIN THIS PRODUCT.**

This system and installation must comply with federal, state and local regulations.

CULLIGAN INTERNATIONAL COMPANY  
One Culligan Parkway  
Northbrook, Illinois 60062-6209  
847.205.6000

# Installation and Operating Instructions with Parts List

## CULLIGAN® ULTRAVIOLET WATER CONDITIONER MODELS FROM 2002



### Table of Contents

	<b>Page</b>
Important Safety Instructions .....	1
Pre-Installation Instructions .....	2-4
Installing the Disinfection Unit.....	5
Mounting Electrical Control Box .....	6
Installing the UV Lamp.....	7-8
Pre-Start Up Sequence .....	9
Start Up Sequence .....	10
Maintenance.....	11-13
Maintenance Log.....	14
Alarms .....	16
Parts List .....	17-18
Troubleshooting.....	19
Technical Specifications .....	20-21
Warranty .....	22







# Safety Instructions

## Important Safety Instructions

**WARNING!** To guard against injury, basic safety precautions must be observed.

### READ AND FOLLOW ALL SAFETY INSTRUCTIONS

	CAUTION! Denotes a potentially dangerous situation. Failure to observe this warning may lead to minor or serious personal injury and material damage.
	ELECTRIC SHOCK! Warning - Dangerous electric voltage. Failure to observe this warning may lead to serious injury or death.
	EYE PROTECTION MUST BE WORN!
	IMPORTANT! Denotes a useful tip and other information.

 CAUTION! Ultraviolet light (UV-C) is harmful to eyes and skin. Use UV lamps only inside the disinfection chamber with the appropriate protective covering. Avoid exposure to UV-C radiation.

 CAUTION! Use disinfection unit only for its intended purpose as described in the Owner's Manual. The use of attachments not recommended or sold by Culligan may cause an unsafe condition.

 CAUTION! Disinfection unit must be properly installed in accordance with the Owner's Manual and in compliance with all applicable local and state regulations before use. Read and observe all important notices on the disinfection unit.

 CAUTION! The Culligan UV disinfection unit is intended for indoor use only.

 ELECTRIC SHOCK! To avoid possible electrical shock, take special care when using water with this equipment. Always shut off and disconnect power to the unit before:

- Making repairs (We strongly recommend that a qualified individual who fully understands the Owner's Manual perform service and/or repairs.)
- Cleaning
- Replacing a UV lamp

 CAUTION! There will be a need to boil water in a failure situation.

 ELECTRIC SHOCK! Do not operate any disinfection unit if it has a damaged cord or plug, if it is malfunctioning, or if it is dropped or damaged in any way.

 ELECTRIC SHOCK! The power cord of disinfection unit is equipped with a 3-prong grounding plug that mates with a standard 3-prong grounded wall outlet to minimize the possibility of electric shock. Be sure the outlet for the disinfection unit is wired and grounded properly. Do Not under any circumstances, cut or remove the third prong from the power cord.

 ELECTRIC SHOCK! Always unplug disinfection unit from outlet when not in use, before putting on or taking off parts, and before cleaning. Never unplug by pulling on the power cord. Always grip plug firmly and pull straight out of the outlet.

 CAUTION! Shut down system before servicing:

- Turn off water supply to the UV disinfection unit.
- Disconnect all power to the UV disinfection unit.
- Drain water from the system.

 EYE PROTECTION MUST BE WORN! Never look at an operating UV light with the naked eye. The light will burn and irritate unprotected eyes and skin.

 EYE PROTECTION MUST BE WORN! Never operate the UV lamp outside of the UV disinfection unit.

## Pre-Installation Instructions

**Before you begin** Perform the following pre-installation steps:

1. Ensure that your Culligan UV system is correct for your flow capacity (see Flow Rate Tables in Technical Specifications.)
2. Ensure that your water supply meets water quality standards as shown in the table below. If any of the elements exceed the recommended maximum, we strongly suggest, at a minimum, that you install a 5-micron sediment filter as particles in the water can reduce UV light intensity and affect performance. Contact the Culligan dealer for additional information about testing and pretreatment equipment.

Element	Recommended maximum levels (1mg/l = 1ppm)	Actual
Suspended solids	<5 mg/l	
Color	None	
Iron	0.3 mg/l	
Manganese	0.05 mg/l	
pH	6.5 to 9.5	
Hardness	<120 ppm	
Hydrogen Sulfide	<0.05 mg/l	

*Note: All models are rated for a minimum UV transmission of 90%. If your transmission is lower, consult the Culligan dealer.*

3. Check the pressure of the water supply. The Culligan UV system is designed to operate at pressures up to 125 psi.

If the pressure is...	Then...
Less than 125 psi	Proceed to step 3
Greater than 125 psi	Install a suitable pressure-reducing valve in the water inlet pipe to the disinfection unit.

4. Fill in the following information and retain for future reference.

Unit Model No. \_\_\_\_\_ Serial No. \_\_\_\_\_

Date Purchased: \_\_\_\_\_ Date Installed: \_\_\_\_\_

Water pressure (psi): \_\_\_\_\_ Water flow rate (gpm): \_\_\_\_\_

5. Select a location that meets the following guidelines.
  - The unit must be installed between the cold water source and the water heater as inlet temperature must not exceed 100°F. (See Figure 1 for proper installation sequence.)
  - The disinfection unit can be installed either horizontally or vertically. (See Figure 3 for water flow direction.)
  - There must be enough clearance to remove the UV lamp and the quartz sleeve for replacement and regular maintenance. Recommended clearance is length of unit plus four inches. (See Figure 4 for additional clearance requirements.)
  - The unit must be within 7 feet of a 110V electrical outlet. A 7'5" cord is included with the unit.
  - The unit must be protected from freezing. Freezing damage will void the warranty.
  - The unit should be placed where a potential leak will not cause water damage. Culligan is not responsible for water damage.

Systems tested and certified by NSF International against NSF/ANSI Standard 55 for disinfection performance, class A.

This system conforms to NSF/ANSI 55 for the disinfection of microbiologically contaminated water that meets all other public health standards. This system is not intended for the treatment of water that has obvious contamination or intentional source, such as raw sewage, nor is this system intended to convert waste water to microbiologically safe drinking water

# Pre-Installation

## Pre-Installation Instructions, Continued

**Figure 1: Installation Sequence**

Figure 1 shows a typical installation sequence.

*Note: that all items may not be necessary for water treatment.*

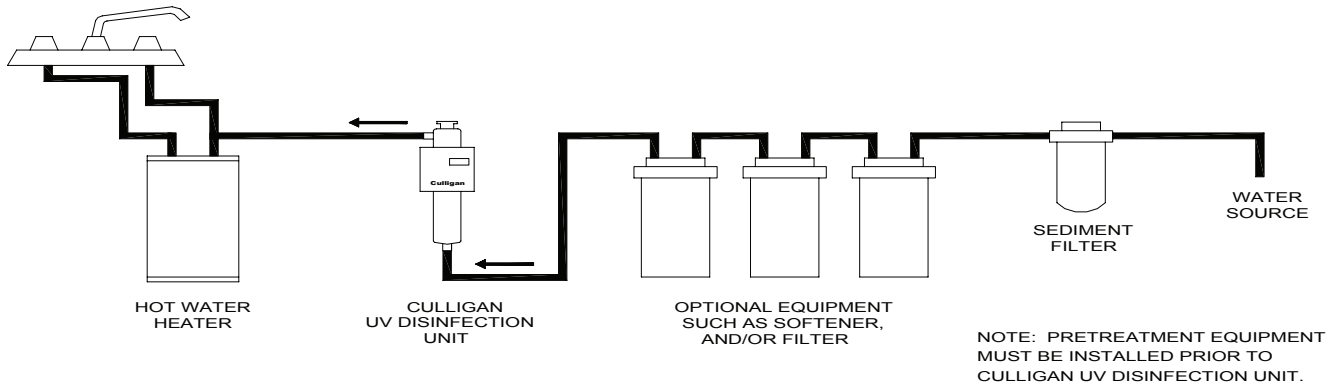

**Figure 2: Installation Planning**

You must determine how to run pipes in and out of your disinfection unit. Figure 2 shows one method of installation (with chamber mounted control box). Use this diagram to determine the materials needed for your installation.

**IMPORTANT!**  
Check local plumbing codes for sizes and types of pipes to be used.

**ELECTRICAL SHOCK!**  
Check for hidden electrical wiring before drilling holes.

The disinfection chamber must be properly grounded to a suitable electrical ground. Check local electrical codes for proper location. Attach ground wire (not included) to stud and nut located on lower area of disinfection chamber.

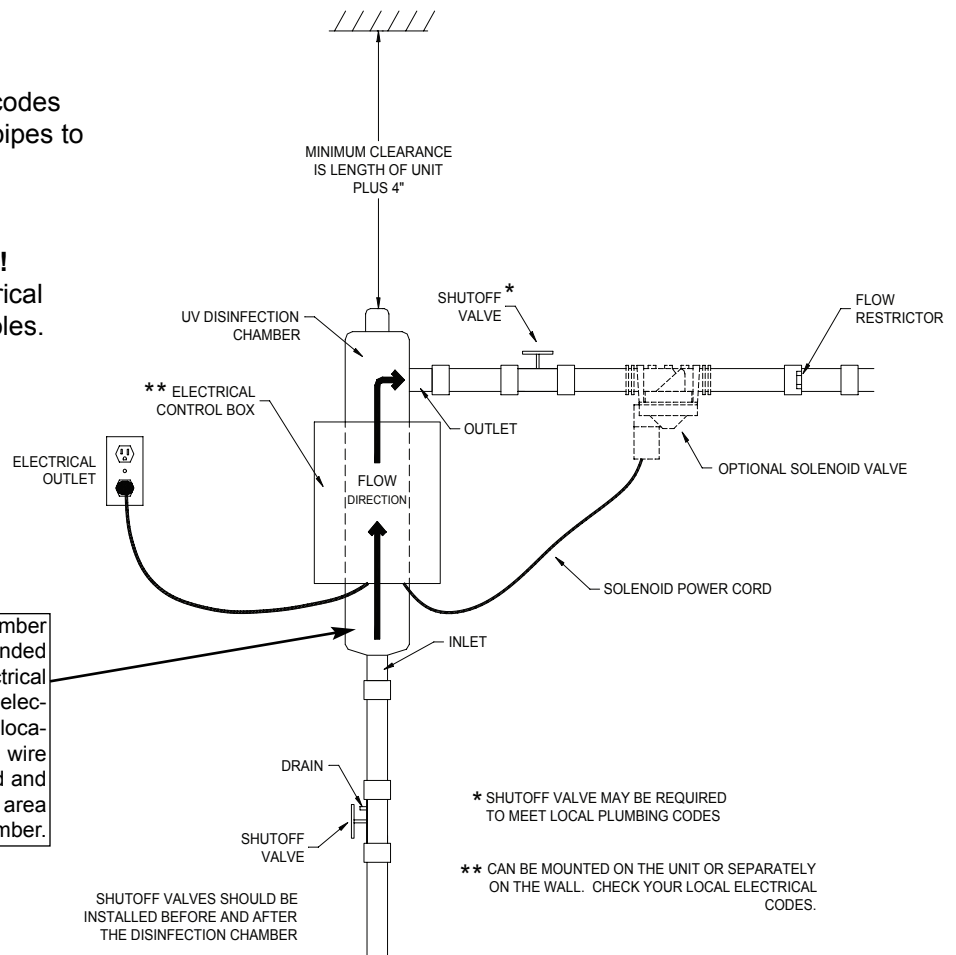

## Pre-Installation Instructions, Continued

**Figure 3: Unit Positioning**

Figure 3 shows proper water flow for horizontal or vertical installation. Make certain that your unit and the inlet and outlet pipes are in the right position for either horizontal or vertical installation.

**! IMPORTANT!** For vertical installation, the inlet is at the bottom and the outlet is near the top of the disinfection chamber. For horizontal installation pay careful attention to the diagram for flow direction.

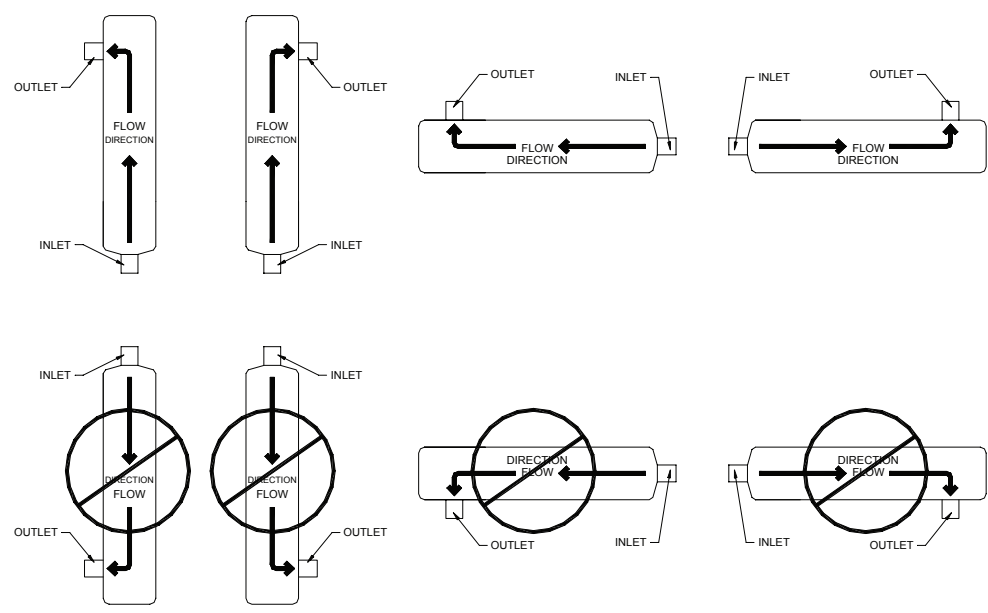

**Figure 4: Clearance Requirements**

Figure 4 provides the clearance requirements needed for proper installation of the disinfection chamber.

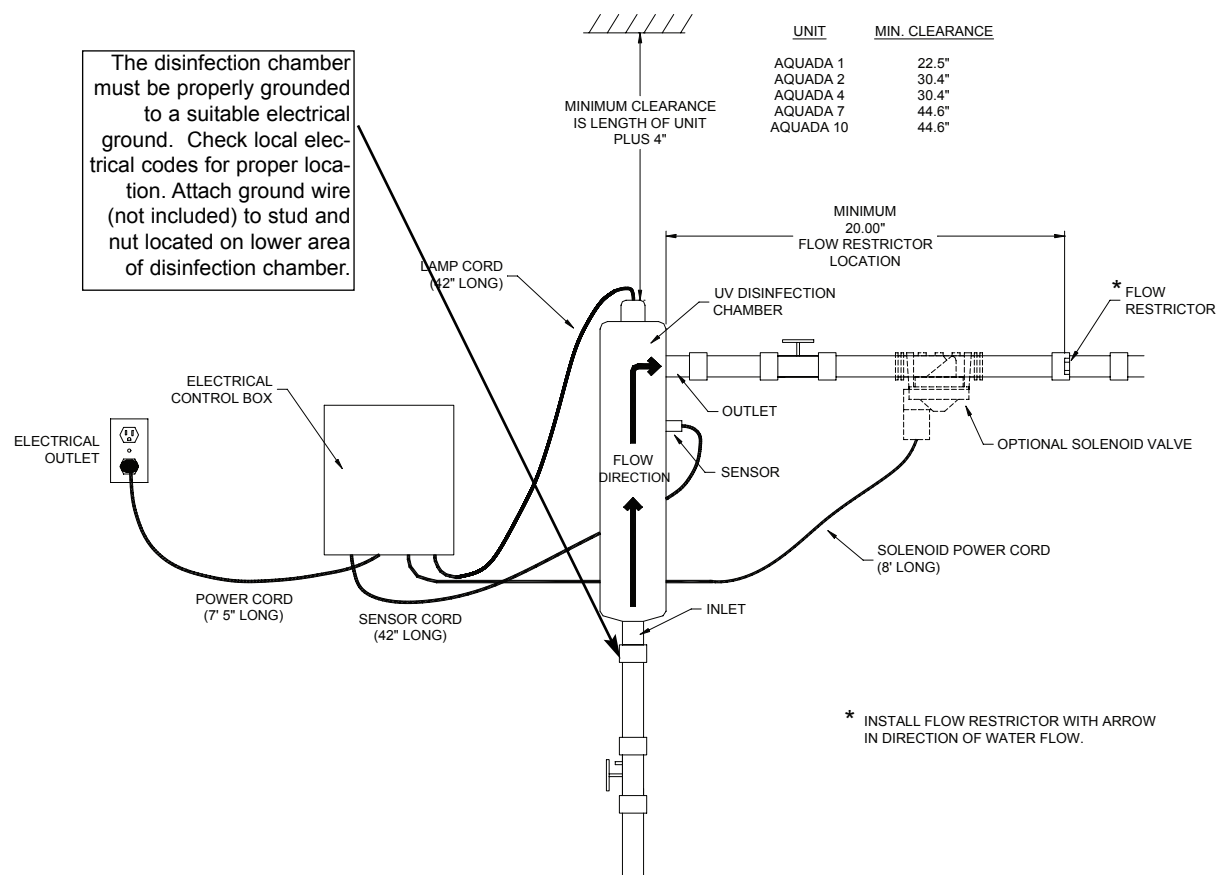

# Installation

## Install the Disinfection Unit

### Attaching unit to wall

Follow these steps to attach Culligan UV disinfection chamber to the wall.

1. Install the two wall mount brackets on the wall using the proper screws for your wall type (screws not included).

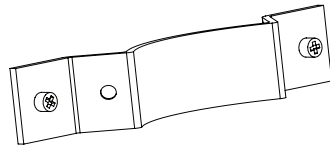

2. Place disinfection chamber in the brackets and secure with the wall mount bracket straps. Use the wall mount bracket strap screws provided to tighten the wall mount bracket straps to the wall mount brackets.

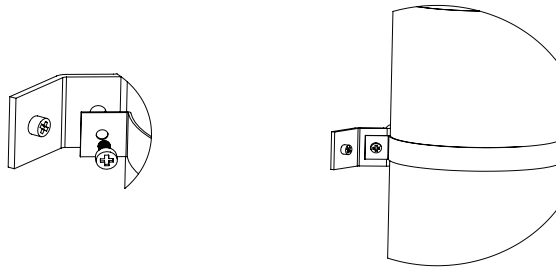

3. Ground disinfection chamber, as shown, to a suitable electrical ground. Check local electrical codes for proper location. (Grounding wire not included.)

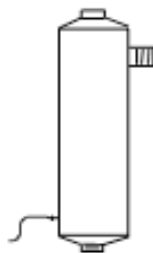

## Mount Electrical Control Box

The electrical control box can be mounted on the wall (Option A) or on the disinfection chamber (Option B), according to the following instructions.

**Option A: Wall mount** Follow these steps to mount the electrical control box on the wall.

1. Attach the optional wall mount bracket to the wall using suitable hardware for your wall surface.

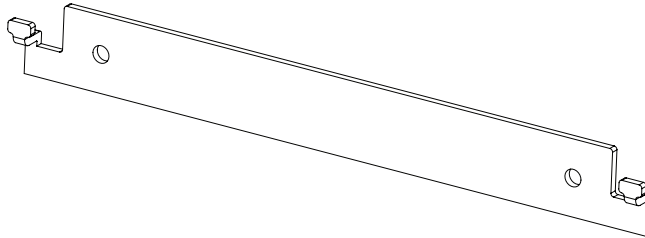

2. Position the keyhole slots on the back of the electrical control box over the tabs on the wall mount bracket and slide into place.

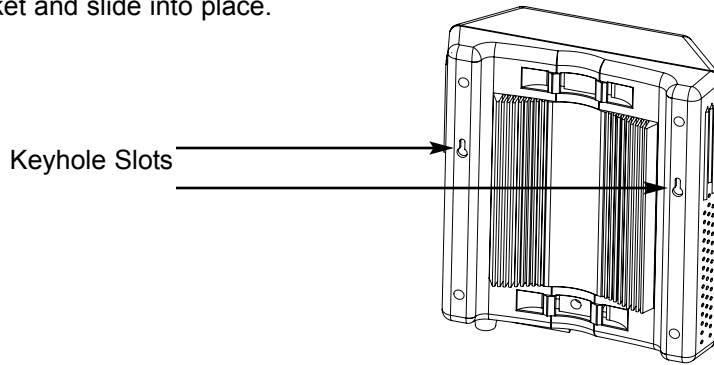

**Option B: Chamber mount** Follow these steps to mount the electrical control box on the disinfection chamber.

1. Feed the electrical box straps through the upper and lower recessed areas on the back of the electrical control box.

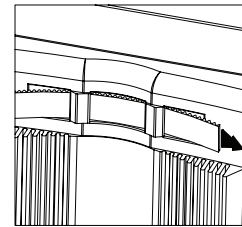

2. Position the electrical control box on the UV disinfection chamber: Wrap the electrical box straps around the chamber, push loose end through high side of Q-Clip, and pull through to tighten.

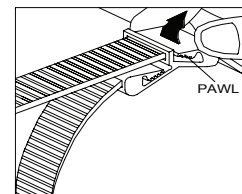
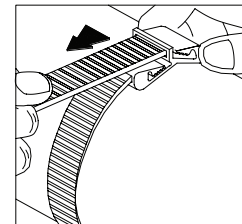

**IMPORTANT!** If it is necessary to remove the electrical box strap, lift the pawl to release it. You may need to use a screwdriver to lift the pawl.

# Installation

## Install the UV Lamp



**CAUTION!** UV lamp is very fragile. Do not handle it with bare hands. Use clean cotton gloves or cloth when handling lamp to keep it free of dust or fingerprints. If dust or fingerprints get on the lamp, wipe it with a clean cloth and alcohol.

### Insert lamp in chamber

Follow these steps to install the UV lamp in the disinfection chamber.

1. Insert the lamp into the headpiece. Gently pinch the two large tabs on the transparent lamp clip and push until the tab locks into the groove (see step 2).

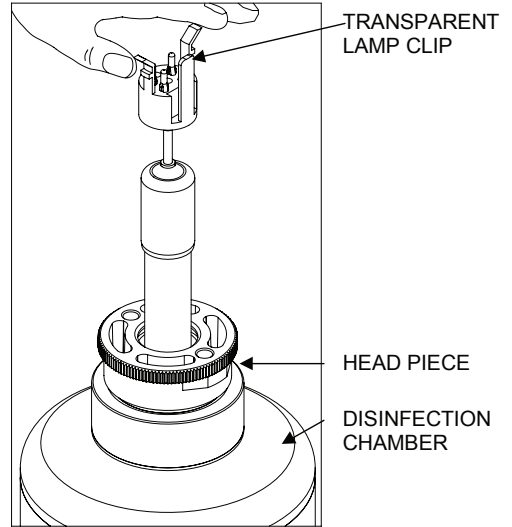

2. Make sure that the transparent tab is properly snapped into the headpiece and is not pushed down too far.

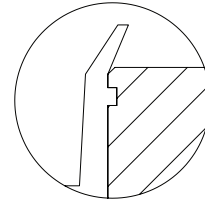
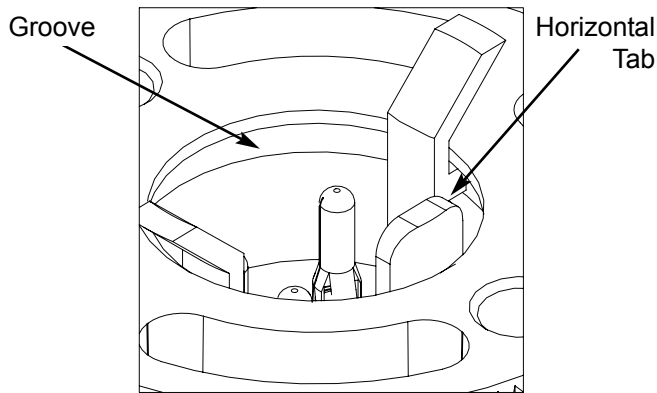

TAB PROPERLY LOCATED IN GROOVE

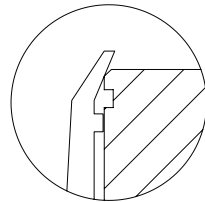

TAB NOT PROPERLY LOCATED IN GROOVE

## Install the UV Lamp, Continued

**Position Glo-Cap** The Glo-Cap must be properly placed on the headpiece for the UV disinfection unit to work. Follow the steps below to position the Glo-Cap.

1. Align the tab on the Glo-Cap with the middle tab on the transparent clip.
2. Lower the Glo-Cap onto the headpiece until it clicks into place. If it does not click into place, make sure that the tabs on the Glo-Cap are not over the raised tabs on the headpiece. If they are, turn the Glo-Cap. When properly installed, the Glo-Cap will not separate from the headpiece.

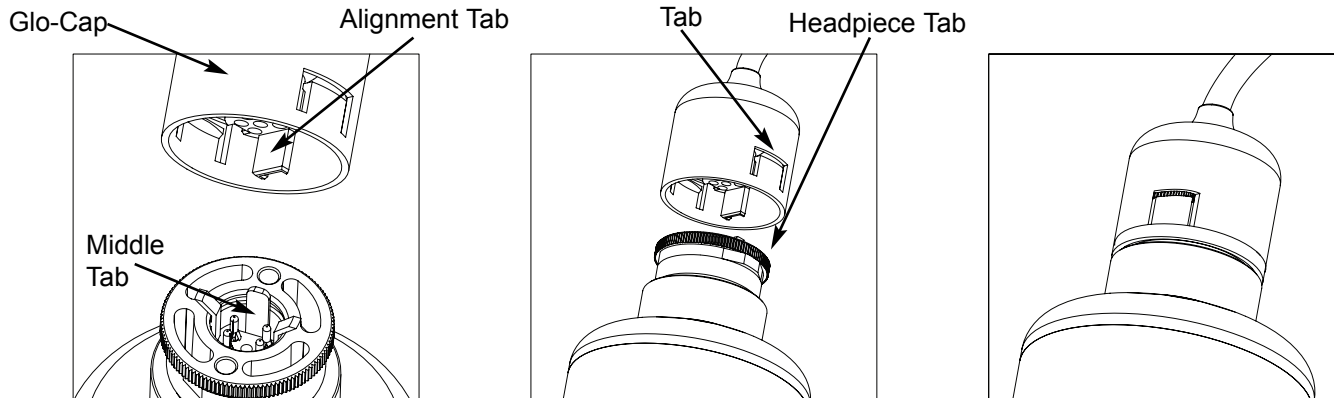

### Attach sensor

The MAXIMA is the only model that comes with a sensor port and sensor assembly. For the **MAXIMA Model only**, attach the sensor assembly to the sensor port on the disinfection chamber, as shown below. **Hand-tighten** the sensor assembly onto the threaded nipple by rotating clockwise until you have a proper seal. Do not use tools on the sensor assembly.

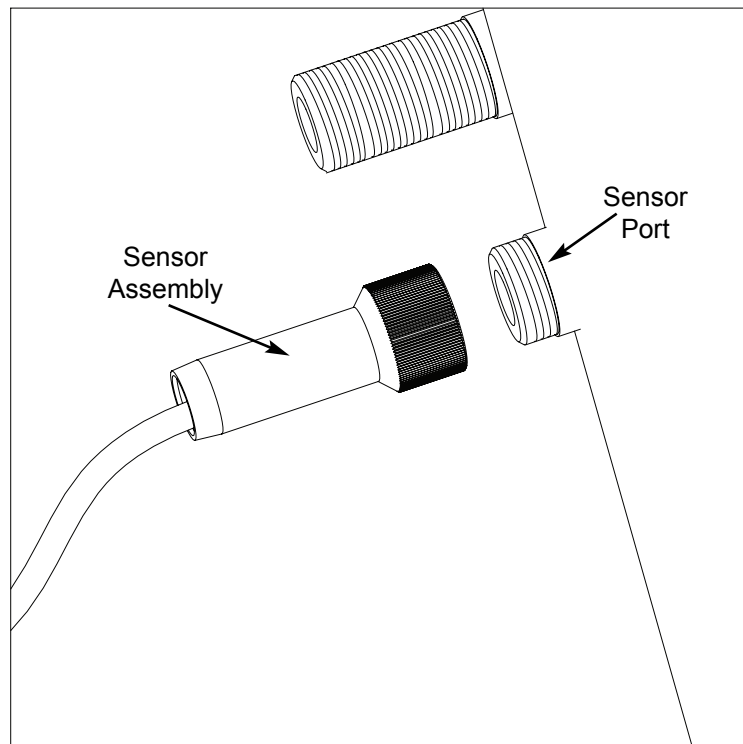



# Pre-Start

## Pre-Start Up Sequence

**Before using the unit...** Follow these steps before operating your Culligan disinfection unit.

1. Check your plumbing:
  - Make sure that new plumbing has no leaks.
  - Flush pipes to purge soldering residue or other debris from the system.
  - Expel air from the system to avoid pressure damage to the unit.
2. Plug solenoid valve (normally closed) into the solenoid valve receptacle located on the bottom of the electrical box.

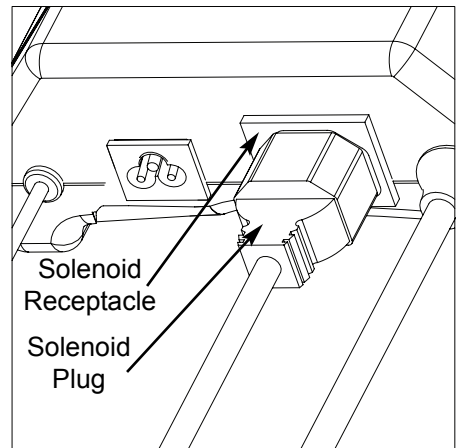

*Note: Solenoid is optional . Culligan recommends installing the solenoid valve on these units. The valve will shut off water supply in the event of certain alarms (see Alarms & Troubleshooting sections).*

3. Plug one end of power cord into receptacle on the bottom of electrical control box, making sure plug is pushed in completely.

**!** **IMPORTANT!** Do not plug power cord into wall outlet until you begin the start-up sequence.

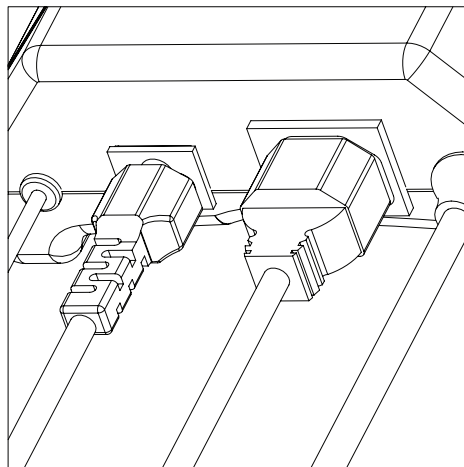

## Start-Up Sequence

**Before using the unit...** Follow the start-up procedures in the table below for your particular unit specifications.

If your unit has...	Then...
UV sensor and no solenoid valve	<p><i>UV sensor is self-calibrating on initial start-up. Proper calibration requires water flow through the unit.</i></p> <ul style="list-style-type: none"> <li>• Slowly fill the unit with water, allowing water to flow through unit.</li> <li>• Plug power cord into wall outlet.</li> <li>• Make sure that the Glo-Cap is lit. You should see a violet/blue light glowing from the Glo-Cap. This is visible light, <b>not</b> UV light and is safe to view with the naked eye.</li> <li>• <b>Within 10 seconds of plugging in the unit</b>, press and hold the reset button for 5 seconds. The unit will beep, the display will be set to 365 days, and the "days remaining" light will be lit.</li> <li>• Wait 5 minutes for the unit to beep again. The display will now alternate between days remaining and UV intensity to indicate the display mode. UV intensity should read "HI" indicating that the lamp is at maximum intensity.</li> <li>• Turn off water flow.</li> <li>• Sanitize your water system before using the disinfection unit (see maintenance section for instructions).</li> </ul>
UV sensor and solenoid valve	<p><i>The UV intensity sensor is self-calibrating on initial start-up. Proper calibration requires water flow through the unit. With the optional solenoid valve installed, a temporary water flow path must be provided for the first five minutes.</i></p> <ul style="list-style-type: none"> <li>• Slowly fill the unit with water, allowing water to flow through the unit.</li> <li>• Plug power cord into wall outlet.</li> <li>• Make sure that the Glo-Cap is lit. You should see a violet/blue light glowing from the Glo-Cap. This is visible light, <b>not</b> UV light and is safe to view with the naked eye.</li> <li>• <b>Within 10 seconds of plugging in the unit</b>, press and hold the reset button for 5 seconds. The unit will beep, the display will be set to 365 days, and the "days remaining" light will be lit.</li> <li>• Wait 5 minutes for the unit to beep again. The solenoid valve will open and the display will alternate every 10 seconds between days remaining and UV intensity, indicating the display mode. UV intensity should read "HI" indicating that the lamp is at maximum intensity.</li> <li>• Turn off water flow.</li> <li>• Sanitize your water system before using the disinfection unit (see maintenance section for instructions).</li> <li>• Flush system for five minutes prior to initial use.</li> </ul>

# Maintenance

## Maintenance

### Required maintenance

Periodically, you will need to perform routine maintenance procedures on your Culligan UV disinfection unit. This section provides directions for:

- Replacing the lamp (every 365 days or in the event of a lamp-out alarm).
- Cleaning the quartz sleeve (as needed).
- Replacing the headpiece O-ring (every 365 days or when needed, based on visual inspection).
- Cleaning the sensor quartz (every 365 days).

### Replacing the lamp

The UV lamp is rated to provide 365 days of continuous use. After this time, it must be replaced for the disinfection unit to operate effectively.

1. Turn off the water supply to the UV disinfection unit.
2. Disconnect all power to the UV disinfection unit and wait several minutes for the lamp to cool.
3. Drain the system: Have a bucket large enough to hold the water in the chamber, close both shut off valves, and open the drain to draw off the water.
4. Remove the Glo-Cap: Rotate the Glo-Cap so that the tabs line up with the raised tabs on the headpiece and pull the cap away from the headpiece to remove it.

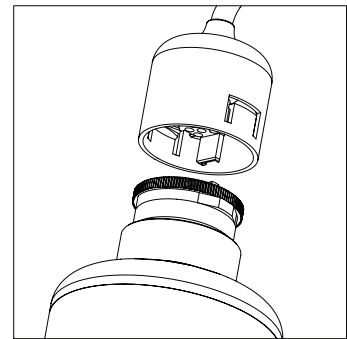
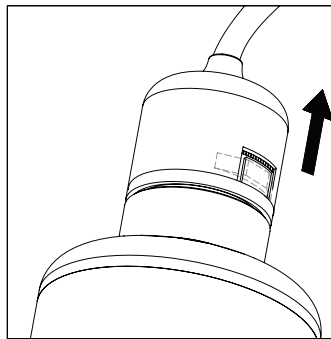
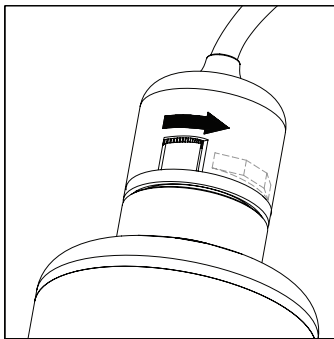

5. Remove the lamp: Gently pinch together the two large tabs on the transparent clip and pull lamp assembly straight up until it is completely removed.

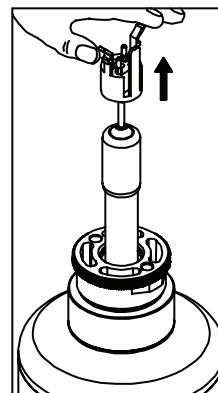
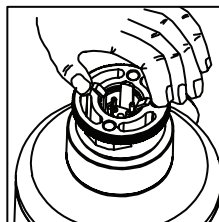

**! IMPORTANT!** Lamp must be disposed of properly. Check your local regulations for disposal of hazardous materials.

6. Insert the new UV lamp (refer to directions for installing the UV lamp).
7. Restart your disinfection unit according to the start-up sequence for your model specifications.
8. Record the date in the maintenance log.
9. Sanitize your water system (see directions in this section).

## Maintenance, Continued

**Cleaning the quartz sleeve, headpiece, O-Ring, & sensor quartz** The quartz sleeve must be kept clean to kill bacteria effectively. Your water quality and mineral content will determine cleaning frequency. Perform a visual inspection after thirty (30) days of operation. If the sleeve is dirty, shorten cleaning intervals. If the sleeve is clean, lengthen cleaning intervals. At this time, clean the headpiece, O-Ring, and sensor quartz assembly also.

1. Fill bucket or other receptacle with warm, soapy water.
2. Follow Steps 1 through 5 for replacing the lamp (see previous page).
3. Unscrew the headpiece and carefully remove the quartz sleeve from the disinfection chamber.  
**IMPORTANT!** The quartz sleeve may stick to the headpiece. Be sure to hold both pieces carefully so they don't separate during removal.

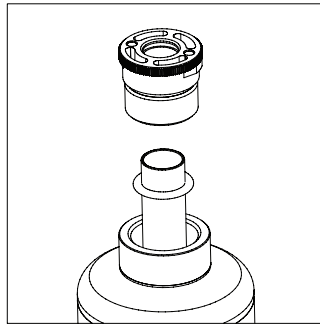

4. Take the headpiece and O-ring off the quartz sleeve. Clean the headpiece, O-Ring, and quartz sleeve with a mild soap and hot water solution. If the sleeve is still not clean, use a mild acid (citric acid or Lime-Away), then rinse with hot water.

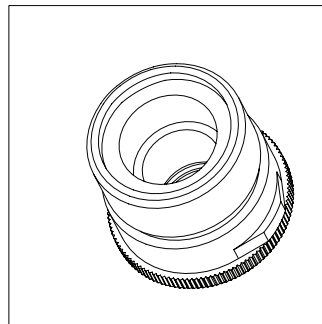

5. Push the O-Ring a few inches down on the quartz sleeve and lower the sleeve into the chamber.

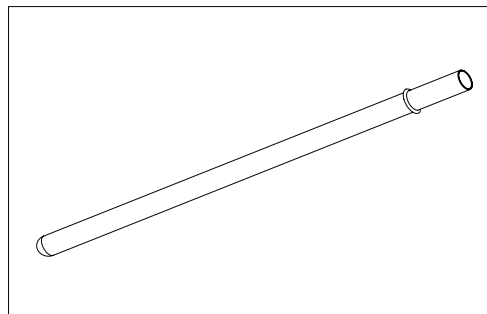

6. Screw the headpiece onto the disinfection chamber to secure the quartz sleeve and O-Ring in place.
7. Carefully reinstall the UV lamp and the Glo-Cap (see directions for installing the UV lamp).
8. Clean the sensor quartz (see directions in this section).
9. Restart your disinfection unit according to the start-up sequence for your model specifications.
10. Record the date in the maintenance log.
11. Sanitize your water system (see directions in this section).

# Maintenance

## Maintenance, Continued

### Replacing the O-Ring

General maintenance for the O-Ring requires that you replace it every 365 days. If, however, during routine cleaning of the quartz sleeve, you find the O-Ring cut, damaged, or extremely dirty, then it should be replaced at this time. To replace the O-Ring, follow the directions for cleaning.

### Cleaning the sensor quartz

Clean the sensor quartz during routine cleaning of quartz sleeve and at least every 365 days.

1. Fill a bucket or other receptacle with warm, soapy water.
2. Turn off the water supply to the disinfection unit.
3. Disconnect all power to the disinfection unit.
4. Drain the system: Have a bucket large enough to hold the water in the chamber, close both shutoff valves, and open the drain to draw off the water.
5. By hand, carefully turn the sensor assembly counter-clockwise to remove it from the sensor port on the disinfection chamber. Do not disassemble the sensor unit.
6. Clean the sensor quartz (quartz window) and O-Ring with warm soapy water. Mild acid (such as citric acid or Lime-Away) may be used on the sensor quartz, if needed. Rinse well.
7. Make sure that all surfaces of the sensor quartz are clean to ensure a good seal and replace the sensor assembly on the sensor port, turning clockwise on the threaded nipple. Hand-tighten only.
8. Restart your disinfection unit according to the start-up sequence for your model specifications.
9. Record the date in the maintenance log.
10. Sanitize your water system (see directions in this section).

### Sanitizing the system

Before initial use of your UV unit and after routine maintenance procedures, you should sanitize your water system to ensure that no organisms are present.

1. Pour household bleach into your water system. If you have a filter container, fill it with bleach. If you have no filter then introduce chlorine directly into your well. The amount of chlorine depends upon the diameter and depth of your well. (Generally, use ½ gallon to treat an 8" diameter/80' deep well and one gallon for anything larger.) You may contact your State Extension Service or a water treatment specialist for additional information.
2. Open hot and cold water taps throughout the house and let the water run until you detect a chlorine odor. To ensure that the hot water heater is also purged, allow the hot water to run until the water becomes cold. (See note below for MAXIMA Model disinfection units.)
3. Turn off the taps and allow the water to stay in the pipeline for about six hours or overnight but not more than 36 hours to avoid corrosion.
4. Open hot and cold water taps throughout the house and let the water run until the chlorine odor disappears.



**IMPORTANT! For MAXIMA Model only, you may get AL2 and/or AL4 alarm buzzer after introducing chlorine into your water system. Press the reset button until the buzzer stops. This will disable buzzer for 5 days. You may need to respond to more than one alarm, following the same procedure.**



# Alarms

## Displays

The front panel of the electrical control box has the following displays:

LED Display	Screen Display	Diagram
Red LEDs indicate: <ul style="list-style-type: none"> <li>DAYS REMAINING</li> <li>LAMP OUT</li> <li>UV INTENSITY</li> </ul>	Display screen indicates: <ul style="list-style-type: none"> <li>Alarms (AL1 to AL5)</li> <li>UV Intensity (HI and LO)</li> <li>Days Remaining (365 to 000)</li> </ul>	



## Alarm activation

The Culligan UV disinfection unit has built in alarms to warn of inefficient performance or lamp failure.

Alarm	What Happens	Cause	How to Resolve
AL4	<ul style="list-style-type: none"> <li>The alarm buzzer sounds for 5 seconds every minute.</li> <li>The UV INTENSITY LED illuminates and the display screen shows LO.</li> <li>Next, the display screen shows AL4.</li> <li>Then, the DAYS REMAINING LED illuminates and shows the number of days remaining.</li> <li>These three messages alternate every 10 seconds.</li> </ul>	The UV intensity has dropped below 70%. Quartz sleeve or sensor may be dirty.  <p><b>!</b> <b>IMPORTANT!</b> Water to the house is being disinfected and the solenoid valve will remain open.</p>	<ul style="list-style-type: none"> <li>Press the RESET button to silence the alarm. The buzzer will shut off for 5 days or until another alarm level is reached. Silence by pressing the RESET button again. The alarm indicator will remain until the problem is resolved.</li> <li>Perform routine maintenance as indicated in the manual.</li> <li>If the problem persists, see Troubleshooting for other suggestions.</li> </ul>
AL2	<ul style="list-style-type: none"> <li>The alarm buzzer sounds continuously.</li> <li>The UV INTENSITY LED illuminates and the display screen shows AL2.</li> <li>Next, the DAYS REMAINING LED illuminates and the display screen shows the number of days remaining.</li> <li>These messages alternate every 10 seconds.</li> <li>If unit has optional solenoid valve, it will turn off water supply.</li> </ul>	The UV intensity has dropped below 50% indicating that there may be a potential problem within the UV disinfection unit. Quartz sleeve or sensor may be dirty.  <p> <b>WARNING!</b> Disinfection may be insufficient to ensure safe drinking water.</p>	<ul style="list-style-type: none"> <li>Press the RESET button once to silence the alarm. The buzzer will sound again after 5 days and can be silenced by pressing the RESET button. The alarm indicator will remain until the problem is resolved.</li> <li>Perform routine maintenance as indicated in the manual.</li> <li>If the problem persists, see Troubleshooting for other suggestions.</li> </ul>

Contact your local Culligan dealer for replacement components. Should service, adjustment, or troubleshooting be needed which is not included in the installation and operation instructions, call your local Culligan dealer.

## Alarms, Continued

Alarm	What Happens	Cause	How to Resolve
AL3	<ul style="list-style-type: none"> <li>• The alarm buzzer sounds continuously.</li> <li>• The DAYS REMAINING LED illuminates and the display screen shows zeros.</li> <li>• Next, the display screen shows AL3 for end of lamp life.</li> <li>• Then, the UV INTENSITY LED illuminates and the display screen shows "HI," "LO," or "AL2."</li> <li>• These messages alternate every 10 seconds.</li> <li>• If unit has optional solenoid valve, it will turn off water supply.</li> </ul>	<p>Days Remaining = 0 (zero). Lamp is at the end of life.</p> <div style="text-align: center;">  <p><b>WARNING!</b> Disinfection may be insufficient to ensure safe drinking water.</p> </div>	<ul style="list-style-type: none"> <li>• Press the RESET button to silence the alarm. The buzzer will shut off for 5 days or until another alarm level is reached. Silence by pressing the RESET button again. The alarm indicator will remain until the problem is resolved.</li> <li>• Replace lamp (refer to directions in the manual).</li> <li>• If the problem persists, see Troubleshooting for other suggestions.</li> </ul>
AL1	<ul style="list-style-type: none"> <li>• Purple light is not visible.</li> <li>• Alarm buzzer sounds continuously.</li> <li>• The LAMP OUT LED turns on and the display screen shows AL1.</li> <li>• Next, the display screen shows AL2.</li> <li>• If unit has optional solenoid valve, it will turn off water supply.</li> </ul>	<p>The lamp has failed and must be replaced. This may be due to improper operation or installation.</p> <div style="text-align: center;">  <p><b>WARNING!</b> UV system is not operational. Do not drink water without boiling or disinfecting by some other means.</p> </div>	<ul style="list-style-type: none"> <li>• Press the RESET button once to silence the alarm. The buzzer will sound again after 5 days and can be silenced by pressing the RESET button. The alarm indicator will remain until the problem is resolved.</li> <li>• Replace lamp (refer to directions in the manual).</li> </ul>
AL5	<ul style="list-style-type: none"> <li>• The alarm sounds for 5 seconds every minute.</li> <li>• The DAYS REMAINING LED illuminates and the display screen shows the actual number of days left.</li> <li>• Next, the display screen shows AL5.</li> <li>• The UV INTENSITY LED illuminates and the display screen shows "HI," "LO," or "AL2."</li> <li>• These messages alternate every 10 seconds.</li> </ul>	<p>The counter has reached 30 days of lamp life remaining. Lamp will need to be replaced within 30 days.</p> <div style="text-align: center;">  <p><b>IMPORTANT!</b> Water to the house is being disinfected and the solenoid valve will remain open.</p> </div>	<ul style="list-style-type: none"> <li>• Press the RESET button to silence the alarm. The buzzer will shut off for 5 days or until another alarm level is reached. Silence by pressing the RESET button again. The alarm indicator will remain until the problem is resolved.</li> <li>• Replace the lamp within 30 days to ensure continued disinfection.</li> </ul>



# Parts List

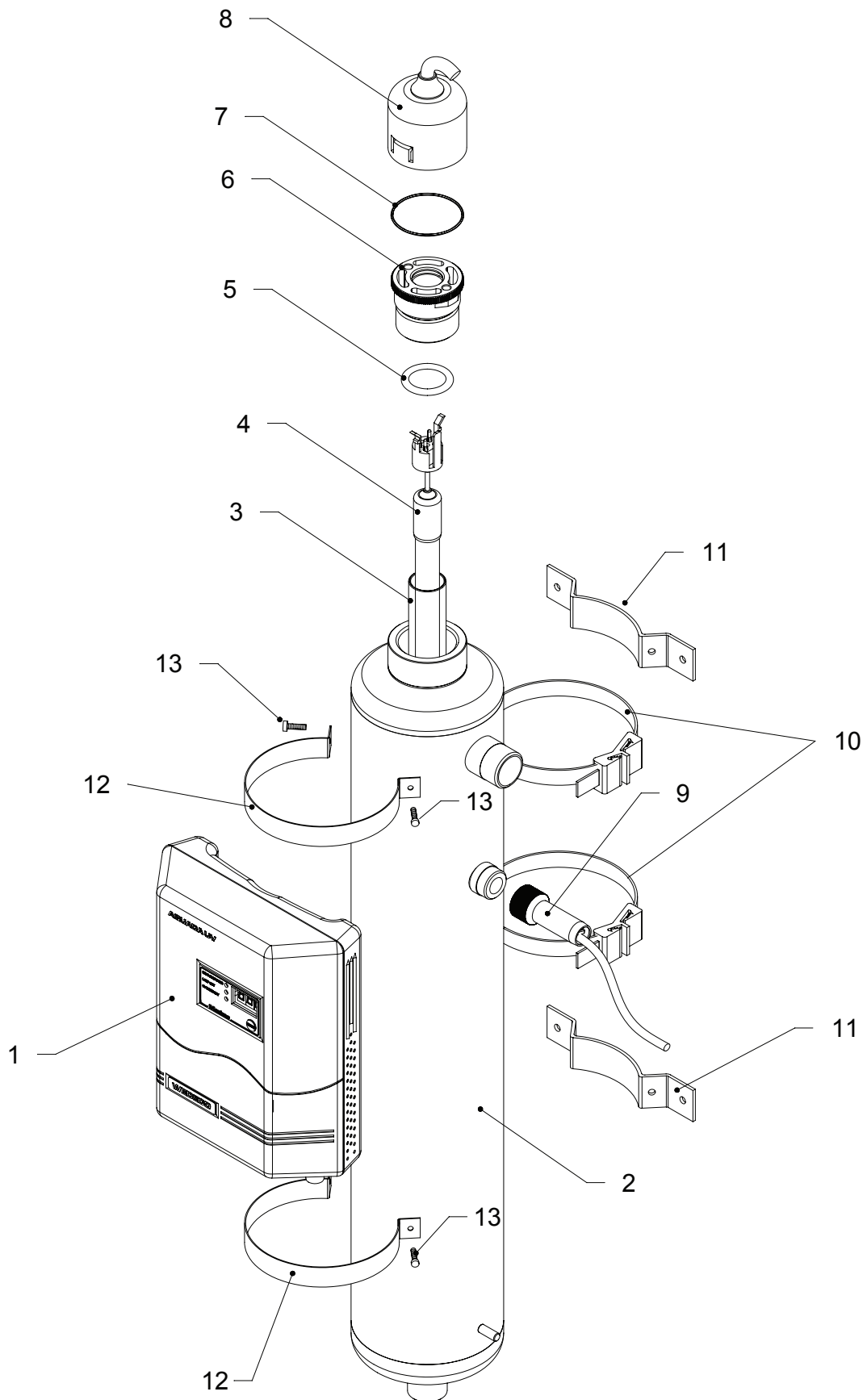

# Parts List

Key#	Part #	Description
1	01015139	Electrical Control Box for 1P - Includes Control Box, Glo-Cap & Glo-Cap O-Ring
1	01015140	Electrical Control Box for 2P - Includes Control Box, Glo-Cap & Glo-Cap O-Ring
1	01016145	Electrical Control Box for 4P - Includes Control Box, Glo-Cap & Glo-Cap O-Ring
1	01016146	Electrical Control Box for 7P - Includes Control Box, Glo-Cap & Glo-Cap O-Ring
1	01015141	Electrical Control Box for 1M - Includes Control Box, Sensor, Glo-Cap & Glo-Cap O-Ring
1	01015142	Electrical Control Box for 2M - Includes Control Box, Sensor, Glo-Cap & Glo-Cap O-Ring
1	01016148	Electrical Control Box for 4M - Includes Control Box, Sensor, Glo-Cap & Glo-Cap O-Ring
1	01016149	Electrical Control Box for 7M - Includes Control Box, Sensor, Glo-Cap & Glo-Cap O-Ring
2	N/A	Disinfection Chamber
3	01015143	Quartz Sleeve for 1P & 1M
3	01015144	Quartz Sleeve for 2P, 2M, 4P & 4M
3	01015145	Quartz Sleeve for 7P & 7M
4	01015146	UV Lamp for 1P & 1M
4	01015147	UV Lamp for 2P, 2M, 4P & 4M
4	01015148	UV Lamp for 7P & 7M
4	01015145	Quartz Sleeve for 7P & 7M
5	01015149	Head Piece O-Ring
6	01015150	Head Piece
7	N/A	Glo-Cap O-Ring
8	N/A	Glo-Cap
9	N/A	Sensor Assembly
10	01015153	Electrical Control Box Mounting Straps (2 Required)
11	01015154	Vessel Mounting Bracket (1Pair), 1 & 2
11	01015155	Vessel Mounting Bracket (1 Pair), 4 & 7
11	01016153	Vessel Mounting Bracket (1 Pair), 10
*	01015156	Remote Wall Mounting Bracket
*	01015157	Flow Control for 1P & 1M, 4GPM
*	01015158	Flow Control for 4P & 4M, 18GPM
*	01016151	Flow Control for 7P & 7M, 30GPM
		Flow Control for 2P & 2M, 10 GPM
*	01015160	1/2" Plastic Normally Closed Solenoid Valve
*	01015162	3/4" Plastic Normally Closed Solenoid Valve
*	01015164	1" Plastic Normally Closed Solenoid Valve
*	01016154	1 1/2" Plastic Normally Closed Solenoid Valve

# Troubleshooting

**Determining problem** The troubleshooting guide gives you suggestions for resolving problems.

If...	Then...
The unit is leaking water	<ul style="list-style-type: none"> <li>• Ensure that the headpiece is tight.</li> <li>• Verify that inlet water pressure is not &gt;125 psi.</li> <li>• Ensure that headpiece O-ring is seated properly.</li> <li>• Lubricate O-ring (use food-grade silicone).</li> <li>• Check O-ring for cracks or rips. Replace if necessary.</li> <li>• Check quartz sleeve for possible cracks. If sleeve is cracked, call Culligan dealer for replacement.</li> </ul>
Glo-Cap is not lit or has gone out(AL1 or AL3)	<ul style="list-style-type: none"> <li>• Verify that all electrical connections are correct.</li> <li>• Replace lamp. If problem is solved, resume unit operation.</li> <li>• Verify ballast output (done by qualified personnel only). If voltage is not within acceptable levels, replace electrical control box.</li> <li>• If lamp still does not light, electrical control box may need to be replaced. Call Culligan dealer for replacement information.</li> </ul>
Poor bacterial performance	<ul style="list-style-type: none"> <li>• Replace lamp if it is more than 365 days old or nearing the end of its lamp life.</li> <li>• Check water quality. If water quality has changed then you may need to install filters or other disinfection units to ensure that water supply does not exceed recommended maximum concentration levels (shown in Step 1 of Pre-Installation Instructions).</li> <li>• Verify flow rate using the flow rate table found in the Technical Specifications at the back of the manual.</li> </ul>
Power fails	<ul style="list-style-type: none"> <li>• The unit will restart automatically and the DAYS REMAINING display will be the same as before the power failure. If the unit has an optional UV sensor, the UV intensity will remain the same as before the power failure. If the unit has an optional solenoid valve installed, the valve will open 5 minutes after power is restored to the unit.</li> </ul> <p><b>Note:</b> <i>The unit is designed for continuous operation. Never connect the unit to a timer or other device, which will cause the unit to cycle on and off. Excessive cycling of the power will reduce lamp life.</i></p>
Display screen is blank	<ul style="list-style-type: none"> <li>• Ensure that the unit is assembled and installed correctly. In the case of improper handling or assembly during installation and/or servicing, the unit will turn off power to the lamp and display a blank screen.</li> <li>• Check for damage to the lamp filament elements, quartz sleeve, or electrode connectors. Applying power to a unit with such damage will cause a blank display screen. Damage may be caused from shipping, overheating the lamp by operating the unit with no water in the chamber, introducing debris into the unit from the water source, or improper handling or assembly during service or installation.</li> </ul> <p><b>Note:</b> <i>Units with the optional solenoid valve installed will turn off. In most cases, replacing the lamp, and/or quartz sleeve will return the unit to proper operation. If the unit fails to resume operation, notify your Culligan dealer.</i></p>
Unit gives faulty alarms	<ul style="list-style-type: none"> <li>• The ballast or control circuit may be faulty. Call Culligan dealer for replacement information.</li> </ul>
You miss the 10 second window for resetting unit	<ul style="list-style-type: none"> <li>• If you miss the 10 seconds allotted to reset the unit, the calibration will be wrong and you may get a UV intensity alarm. Disconnect the power for 30 seconds. Then supply power and restart the unit by pressing the reset button within 10 seconds.</li> </ul>

# Technical Specifications

**Technical Specifications:** All prices and specifications are subject to change without notice.

## Technical Description

Description	The Culligan UV Series is designed with a single low pressure high intensity UV lamp centered inside a protective quartz sleeve. The disinfection chamber is either 304 or 316L stainless steel and is electro-polished with male NPT Inlet/Outlet. The UV lamp and quartz jacket assembly are easily removable from one side of the disinfection chamber. The system incorporates a unique Glo-Cap to give visual indication of the lamp operations.
UV disinfection chamber	<ul style="list-style-type: none"> <li>• Material: stainless steel electro-polished</li> <li>• UV sensor</li> <li>• Mounting: vertical or horizontal</li> <li>• Inlet/Outlet connections: Male NPT thread</li> <li>• Mounting brackets included</li> </ul>
UV lamp	High output low pressure UV lamp
UV sensor (Maxima only)	One selective sensor, selectivity > 99% at 254 nm, non-aging
Control Box	<ul style="list-style-type: none"> <li>• Material: ABS, designed for wall or UV chamber mounting</li> <li>• Electronic power supply (ballast)</li> <li>• 3-digit LED readout (Proxima and Maxima only)</li> <li>• Solenoid valve activator outlet (Proxima and Maxima only)</li> <li>• Cable length UV chamber/control box: 4.9'</li> </ul>
Models	<ul style="list-style-type: none"> <li>• Maxima</li> </ul>
Application	The Culligan UV Series is engineered to disinfect clear fresh water to meet drinking water standards.
Operational capacity	Clear fresh water up to 30 US GPM
Options	<ul style="list-style-type: none"> <li>• Voltages 230 Volt / 50 or 60 Hz (CE conforming)</li> <li>• Solenoid inlet valve (Maxima and Proxima: NPT size corresponding to reactor NPT connection for each unit) 3/4", 1", and 1 1/2" normally closed.</li> </ul>

**Flow Rate Table: Valid for water with minimum UV transmission  $\geq 90\%$  @1 cm (254 nm).**

Culligan UV type	M1	M2	M4	M7
Flow rate (gpm) at UV dose of 40 mJ/cm <sup>2</sup> at the end of lamp lifetime*	4	10	18	30

\* 40 mJ/cm<sup>2</sup> = 40,000  $\mu$ Ws/cm<sup>2</sup>

**Notes:** (1) Flow rates subject to final bioassay results  
(3) Flow rate based on flow restrictor installed in line

UV Reactor, Stainless Steel 304 (1.4301) Electro-polished

Reactor connections, male NPT thread	1/2"	3/4"	3/4"	1"
Width (inches)	3.54	3.54	5	5
Height (inches)	18.5	26.38	26.38	40.55
Diameter (inches)	2.76	2.76	4.02	4.02
Weight (lb.) approx.	3.75	5.29	7.06	11.03
Operating pressure (psi) min./max.	20/125	20/125	20/125	20/125
Pressure loss (psi) approx.	2	2	2	2
Min. Temperature	40/100	40/100	40/100	40/100

UV Lamp, Low Pressure High Output

Lamp Type	01015146	01015147	01015148	01015147
Lamp Power (Watt)	16.5	40	40	84
UV-C Output at 254 nm, new lamp (Watt)	5.5	14	14	25
Quantity	1	1	1	1
Lamp lifetime (days)	365	365	365	365

# Technical Specifications

## Technical Specifications: Continued

### Control Box

Culligan UV type	M1	M2	M4	M7
Width (inches) approx.	6.61	6.61	6.61	6.61
Height (inches) approx.	7.87	7.87	7.87	7.87
Depth (inches) approx.	2.6	2.6	2.6	2.6
Weight (lb) approx.	5.51	5.51	5.51	5.51
Voltage (V/Hz)	120V/60Hz	120V/60Hz	120V/60Hz	120V/60Hz
Cable length chamber/cabinet (ft)	4.9	4.9	4.9	4.9
Ambient temperature (°F)	95	95	95	95
Power consumption (W)	35	55	55	95

The Maxima model is available in different sizes based on flow capacity. The varying technical features of the model are described below.

### Model Characteristics

Features	MAXIMA
Tested and proven disinfection capacity	•
Electro-polished stainless steel disinfection chamber	•
High output low pressure UV lamp	•
High efficiency electronic ballast power supply	•
Glo-Cap lamp operation indicator	•
Safety lamp connector (no lamp removal without lamp shut-off)	•
Micro-computer control	•
Audible alarm plus visual alarm display (lamp failure and end of lamp life)	•
Lamp change reminder with 365-day counter	•
Alarm and computer reset button	•
Selective UV monitoring system	•
Digital UV intensity display: low/medium/high (with separate UV intensity alarm)	•
Power connection for optional automatic solenoid safety shut-off valve	•

NSF Class A information pertains to the Maxima Model (with UV sensor) only.

This Class A System conforms to NSF/ANSI 55 for the disinfection of microbiologically contaminated water that meets all other public health standards. The system is not intended to convert wastewater or raw sewage to drinking water. The system is intended to be installed on visually clear water.

NSF/ANSI 55 defines wastewater to include human and/or animal body waste, toilet paper, and any other material intended to be deposited in a receptacle designed to receive urine and/or feces (blackwaste); and other waste materials deposited in plumbing fixtures (greywaste).

If this system is used for the treatment of untreated surface water or ground water under the direct influence of surface water, a device found to be in compliance for cyst reduction under the appropriate NSF/ANSI Standard shall be installed upstream of the system.

# CULLIGAN LIMITED WARRANTY

## ULTRAVIOLET WATER CONDITIONERS

You have just purchased one of the finest water conditioners made. As an expression of our confidence in Culligan International Company products, your water conditioner is warranted to the original end-user, when installed in accordance with Culligan International Company specifications, against defects in material and workmanship from the date of original installation, as follows:

**For a period of ONE YEAR ... UV water conditioner**  
**For a period of TWO YEARS ... Electrical parts**  
**For a period of TEN YEARS ... UV chamber**

If a part described above becomes defective, within the specified period, you should notify your independently operated Culligan dealer and arrange a time during normal business hours for the dealer to inspect the water filter on your premises. Any part found defective within the terms of this warranty will be repaired or replaced by the dealer. You pay only freight from our factory and local dealer charges.

We are not responsible for damage caused by accident, fire, flood, freezing, Act of God, misuse, misapplication, neglect, alteration, installation or operation contrary to our printed instructions, or by the use of accessories or components which do not meet Culligan specifications, is not covered by this warranty.

Our product performance specifications are furnished with each water filter unit. TO THE EXTENT PERMITTED BY LAW, CULLIGAN DISCLAIMS ALL IMPLIED WARRANTIES, INCLUDING WITHOUT LIMITATION WARRANTIES OF MERCHANTABILITY AND FITNESS FOR PARTICULAR PURPOSE; TO THE EXTENT REQUIRED BY LAW, ANY SUCH IMPLIED WARRANTIES ARE LIMITED IN DURATION TO THE ONE-YEAR PERIOD SPECIFIED ABOVE FOR THE ENTIRE CONDITIONER. As a manufacturer, we do not know the characteristics of your water supply or the purpose for which you are purchasing a water filter. The quality of water supplies may vary seasonally or over a period of time, and your water usage rate may vary as well. Water characteristics can also differ considerable if your water conditioner is moved to a new location. For these reasons, we assume no liability for the determination of the proper equipment necessary to meet your requirements, and we do not authorize others to assume such obligations for us. Further, we assume no liability and extend no warranties, express or implied, for the use of this product with a non-potable water source. CULLIGAN'S OBLIGATIONS UNDER THIS WARRANTY ARE LIMITED TO THE REPAIR OR REPLACEMENT OF THE FAILED PARTS OF THE WATER CONDITIONER, AND WE ASSUME NO LIABILITY WHATSOEVER FOR DIRECT, INCIDENTAL, CONSEQUENTIAL, SPECIAL, GENERAL, OR OTHER DAMAGES.

**Some states do not allow the exclusions of implied warranties or limitations on how long an implied warranty lasts, so the above exclusion may not apply to you. Similarly, some states do not allow the exclusion of incidental or consequential damages, so the above limitation or exclusion may not apply to you. This warranty gives you specific legal rights, and you may also have other rights which vary from state to state. Consult your telephone directory for your local independently operated Culligan dealer, or write Culligan International Company for warranty and service information.**

CULLIGAN INTERNATIONAL COMPANY  
One Culligan Parkway  
Northbrook, Illinois 60062



# PRODUCT BULLETIN

# FILTRASORB® 300 & 400

## GRANULAR ACTIVATED CARBONS FOR POTABLE WATER

### DESCRIPTION

Filtrisorb 300 and Filtrisorb 400 are two high activity granular activated carbons developed by Calgon Carbon Corporation for the removal of taste and odor compounds and dissolved organic compounds from water treatment.

These activated carbons are manufactured from select grades of bituminous coal to produce a high activity, durable granular product capable of withstanding the abrasion associated with repeated backwashing, air scouring, and hydraulic transport. Activation is carefully controlled to produce exceptionally high internal surface area with optimum pore size for effective adsorption of a broad range of high and low molecular weight organic contaminants. The product is also formulated to comply with all the applicable provisions of the AWWA Standard for Granular Activated Carbon edition B604-96, the stringent extractable metals requirements of ANSI/NSF Standard 61 and Food Chemicals Codex.

### APPLICATIONS

Filtrisorb 300 and 400 activated carbons can be used to treat surface and ground water sources for the production of drinking water. These products can be used as a complete replacement for sand or anthracite media. Filtrisorb 300 and 400 activated carbons function as dual purpose media, providing both filtration and adsorption.

### DESIGN CONSIDERATIONS

As a replacement for existing filter media, conversion to Filtrisorb 300 and 400 activated carbons impose no major changes to a plant's normal filtration operations. Calgon Carbon Corporation can also provide complete modular adsorption systems as an add-on treatment stage if required.

### SPECIFICATIONS

	F300	F400
Iodine Number, mg/g (Min.)	900	1000
Moisture, weight % (Max. %)	2	2
Abrasion Number (Min.)	78	75
Effective Size, mm	0.8-1.0	0.55-0.75
Uniformity Coefficient (Max.)	2.1	1.9
Sieve Size, U.S. Sieve Series, weight %		
Larger than No. 8 (Max.)	15	-
Smaller than No. 30 (Max.)	4	-
Larger than No. 12 (Max.)	-	5
Smaller than No. 40 (Max.)	-	4
Ash, weight % (Max.)	8	9
Apparent Density, g/cc (Min.)	0.48	0.44

**FILTRASORB 300 - BED EXPANSION  
BACKWASHED & SEGREGATED BED**

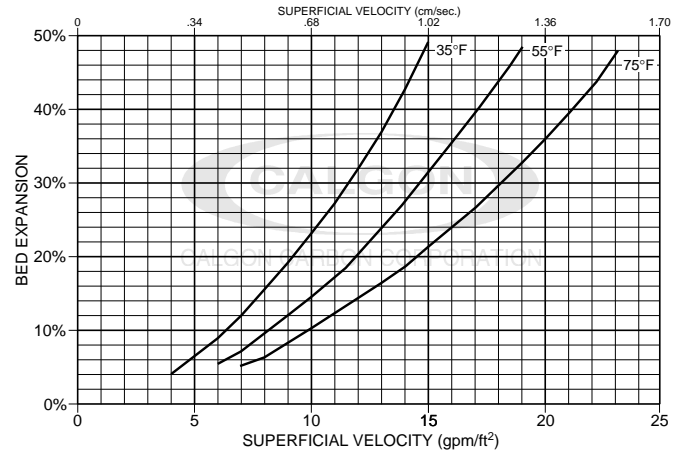

**FILTRASORB DOWNFLOW PRESSURE DROP  
BACKWASHED & SEGREGATED BED**

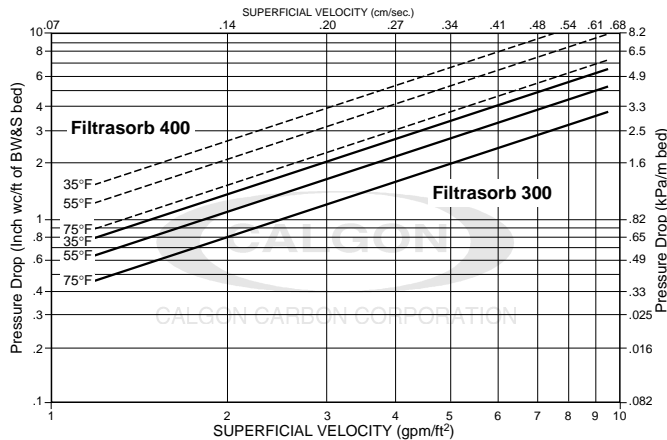

**FILTRASORB 400 - BED EXPANSION  
BACKWASHED & SEGREGATED BED**

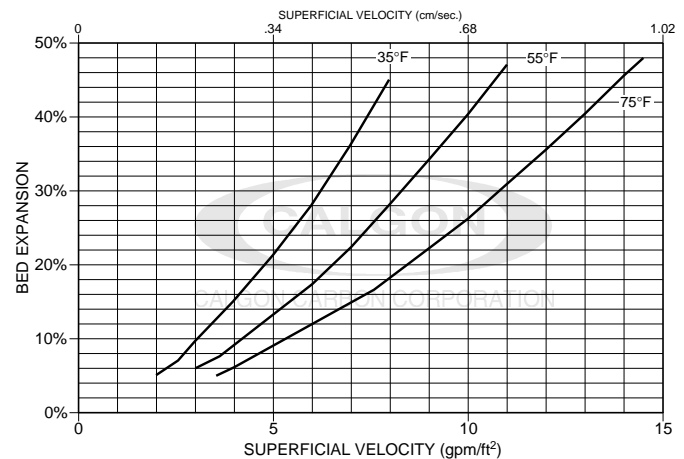

## PACKAGING

55 Pound (25 kg) 5 Ply Bag  
1,000 Pound (453.7 kg) Super Sack  
Bulk Trucks

## MANUFACTURING

Catlettsburg, KY  
Pearlington, MS

## FEATURES

- Bituminous-based raw material
- High density
- Coal is pulverized and reagglomerated with suitable binder

## BENEFITS

- Provides higher hardness relative to other raw materials reducing the generation of fines and product losses during backwashing.
- Pore structure provides a wider range of contaminant removal capabilities relative to other starting materials.
- Filtrasorb activated carbons are of high density, wet readily, and do not float, thus minimizing loss during backwash operations.
- Creates optimal transport paths for faster adsorption.
- Generates the hardness and abrasion resistance required for thermal reactivation and minimizes generation of fines in operations requiring backwashing.

## SAFETY MESSAGE

Wet activated carbon preferentially removes oxygen from air. In closed or partially closed containers and vessels, oxygen depletion may reach hazardous levels. If workers are to enter a vessel containing carbon, appropriate sampling and work procedures for potentially low oxygen spaces should be followed, including all applicable federal and state requirements.

## 1-800-4-CARBON

[www.calgoncarbon.com](http://www.calgoncarbon.com)

### Domestic Sales Offices

#### **Region I**

Bridgewater, NJ  
Tel (908) 526-4646  
Fax (908) 526-2467

#### **Region II**

Pittsburgh, PA  
Tel (412) 787-6700  
1-800-4-CARBON  
Fax (412) 787-6676

#### **Region III**

Richmond, CA  
Tel (510) 412-1010  
Fax (510) 412-5660

#### **Region IV**

Houston, TX  
Tel (713) 690-2000  
Fax (713) 690-7909

### International Sales Offices

#### **Australasia/Philippines/ Southeast Asia**

Calgon Carbon Asia  
Singapore Office  
Tel (65) 221-3500  
Fax (65) 221-3554

#### **Canada**

Calgon Carbon Canada, Inc.  
Bolton, Ontario  
Tel (905) 857-9915  
Fax (905) 857-9984

#### **China/Korea/Taiwan**

Calgon Carbon Asia  
Tokyo Office  
Tel 81 3 3560 7505  
Fax 81 3 3584 7202

#### **Europe**

Chemviron Carbon  
B-1200 Brussels, Belgium  
Tel 32 2 773 02 11  
Fax 32 2 770 93 94

#### **Japan**

Calgon Far East  
Tokyo Office  
Tel 81 3 3582 1861  
Fax 81 3 3586 9266

#### **Latin America**

Pittsburgh, PA  
Tel (412) 787-4519  
Fax (412) 787-4523

Calgon Carbon Corporation's activated carbon products are continuously being improved and changes may have taken place since this publication went to press.



CALGON CARBON CORPORATION



# Information Bulletin

## ACTIVATED CARBON WHAT IS IT, HOW DOES IT WORK

In the last decade public awareness and concern over the quality of drinking water has resulted in more and more consumers turning to point-of-use devices for treating water to their own desired level of quality. This is reflected in the market for home water filters, designed to remove objectionable tastes and odors and organic contaminants from water, which has experienced substantial growth. The material in these filters, activated carbon, is recognized as effective and reliable in removing impurities. Activated carbon has a tremendous adsorptive capacity, an affinity for a wide variety of dissolved organics and chlorine and an ability to be custom-tailored to suit specific applications.

But what is activated carbon, and how does it work? How do carbon products differ? How do products and operating conditions affect the efficiency of a POU treatment system?

### What is Activated Carbon?

The primary raw material used for activated carbon is any organic material with a high carbon content (coal, wood, peat, coconut shells). Granular activated carbon is most commonly produced by grinding the raw material, adding a suitable binder to give it hardness, re-compacting and crushing to the correct size. The carbon-based material is converted to activated carbon by thermal decomposition in a furnace using a controlled atmosphere and heat.

The resultant product has an incredibly large surface area per unit volume, and a network of submicroscopic pores where adsorption takes place. The walls of the pores provide the surface layer molecules essential for adsorption. Amazingly, one pound of carbon (a quart container) provides a surface area equivalent to six football fields.

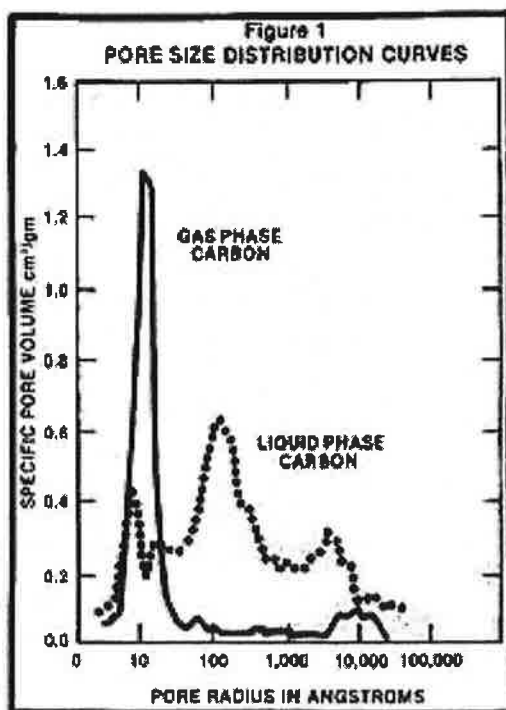

### How Does Activated Carbon Work?

Physical adsorption is the primary means by which activated carbon works to remove contaminants from water. Carbon's highly porous nature provides a large surface area for contaminants (adsorbates) to collect. In simple terms, physical adsorption occurs because all molecules exert attractive forces, especially molecules at the surface of a solid (pore walls of carbon), and these surface molecules seek other molecules to adhere to. The large internal surface area of carbon has many attractive forces which work to attract other molecules. Thus contaminants in water are adsorbed (or held) to the surface of carbon by surface attractive forces similar to gravitational forces. Adsorption from solution occurs as a result of differences in adsorbate concentration in the solution and in the carbon pores. The adsorbate migrates from the solution through the pore channels to reach the area where the strongest attractive forces are.

With this understanding of how the adsorption process works, we must then understand why it works, or why water contaminants become adsorbates.



Visit our website at [www.calgoncarbon.com](http://www.calgoncarbon.com), or call 1-800-4-CARBON to learn more about our complete range of products and services, and local contact information.

**Chemviron**  
**Carbon**

Water contaminants adsorb because the attraction of the carbon surface for them is stronger than the attractive forces that keep them dissolved in solution. Those compounds which are more adsorbable onto activated carbon generally have a lower water solubility, are organic (made up of carbon atoms), have a higher molecular weight, and a neutral or non-polar chemical nature. It should be pointed out that for water adsorbates to become physically adsorbed onto activated carbon, they must be both dissolved in water and smaller than the size of the carbon pore openings so that they can pass into the carbon pores and accumulate.

Besides physical adsorption, chemical reactions can occur on a carbon surface. One such reaction is chlorine removal from water involving the chemical reaction of chlorine with carbon to form chloride ions. This reaction is important to POU treatment because this conversion of chlorine to chloride is the basis for the removal of some common objectionable tastes and odors from drinking water.

**TABLE 1**  
**Typical Properties of Activated Carbons**  
**Produced from Different Raw Materials**

	Bituminous	Sub-Bituminous	Lignite
iodine Number	1,000	1,000	600
Molasses Number	235	230	300
Abrasion Number	80	75	60
Bulk Density as packed in column pounds/ft <sup>3</sup>	26	25	23
Volume Activity	26,000	25,000	13,800
%Ash	6.7	12.3	20.1
*%Phosphorus on Carbon	< .05%	1-5%	< .05%

\*Part of ash which can form a precipitate in hard water areas.

### What are the Properties of Activated Carbon?

Activated carbon products can be characterized by physical properties and activity properties. Both physical and activity properties become important factors in the specification of commercial carbons for POU applications.

Important physical properties are surface area, product density, mesh size, abrasion resistance and ash content. In water treatment applications, carbon density is expressed as back-washed and drained (BWD) or bulk density. This establishes the number of pounds of carbon required to fill a

back-washable filter, and is expressed in terms of pounds per cubic foot.

Mesh size (8x30, 12x40, 20x50, etc.) establishes the range of particle sizes and thus, the effective particle size which will be used in a filter. Particle size is an important parameter in specifying carbons for specific applications, affecting such operating conditions as pressure drop, filtration capabilities, backwash rate requirements and the rate of adsorption of contaminants. While a smaller particle size effects more pressure drop across a carbon bed, the rate of diffusion of an organic into the pore and its subsequent adsorption is significantly increased.

Another important characteristic that distinguishes different types of liquid phase carbons is abrasion resistance. Abrasion resistance refers to a carbon's ability to withstand degradation during handling and is expressed in terms of abrasion number. The higher the abrasion number, the more resistant the carbon is to abrasion.

The final important physical property of activated carbon is ash level, which reflects the purity of the carbon. It is the inorganic residue left after heating of the raw material. Common as constituents of coal-based carbons are silica, alumina, iron, calcium and magnesium.

Activity characterizations are key indicators of a carbon's potential performance for removing contaminants from water. An important characterization tool used in determining the ability of a carbon to adsorb a particular adsorbant is the pore size distribution, which is usually depicted in the form of a curve (Figure 1). The pore size distribution is produced through adsorption of gases and liquids under pressure. It defines the available pore volume of a carbon over three pore size regions: The micropore region (less than 100 Angstroms\* in size), mesopore region (between 100 and 1,000 Angstroms), and macropore region (greater than 1,000 Angstroms).



Calgon Carbon Corporation  
P.O. Box 717  
Pittsburgh, Pa 15230

Chemviron Carbon  
Zoning Industriel C  
B-7181 Feluy, Belgium

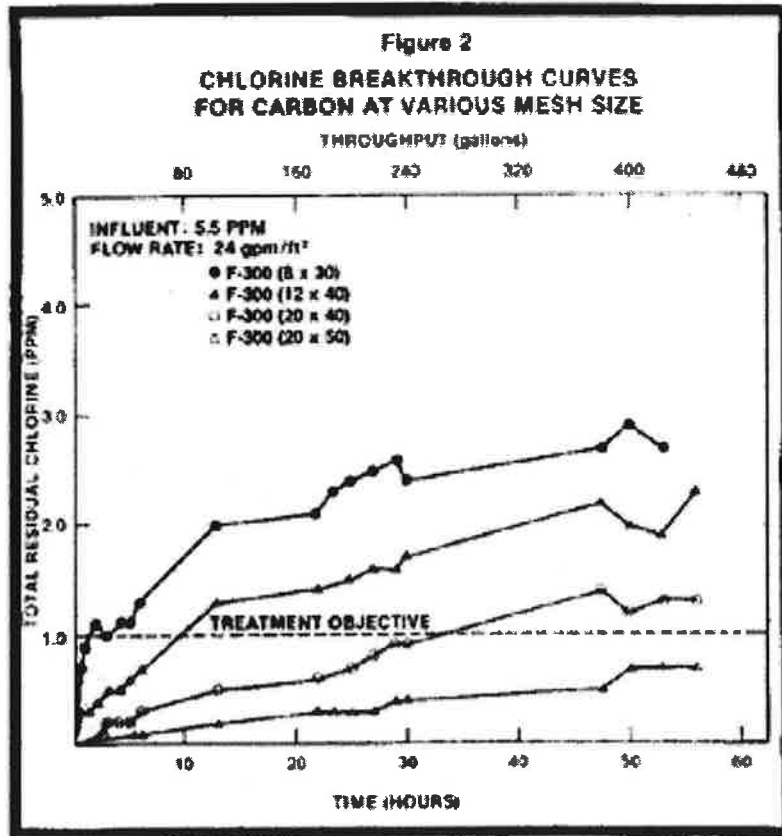

Figure 1 shows the difference in pore size distribution between a carbon used for a gas phase application and that used for a liquid phase application. The molecules encountered in gas phase are generally smaller and more mobile than those in liquid phase applications. Therefore, a gas phase carbon has the majority of its pores concentrated in the micropore region. There is a wider range of molecular sizes in liquid phase work (taste and odor, color bodies, organics, pesticides), and adsorbates are less mobile in water. This means a broader range of pore sizes must be available, both for ease of movement of adsorbates through the carbon pores and for adsorption of particular molecular sizes.

Inexpensive tests have traditionally been used to approximate the distribution of pores available for a carbon as just described. These tests include the adsorption of a single standard reference adsorbate, and give the ability to distinguish activity characteristics of different carbons.

Iodine is the most common standard adsorbate and is often used as a general measurement of carbon capacity. However, because of its small molecular size, Iodine more accurately defines the small pore or micropore volume of a carbon and thus reflects its ability to adsorb low molecular weight, small substances. Iodine number is defined as the milligrams of Iodine adsorbed by one gram of carbon, and it approximates the internal surface area (square meters per gram).

Molasses number is a measure of the degree of de-colorization of a standard molasses solution. Because color pigments are large and cannot penetrate into small pores, the molasses number defines the large pore or macropore volume of a carbon. It is used as a relative guideline for measuring the capacity of a carbon for larger adsorbate molecules.



Visit our website at [www.calgoncarbon.com](http://www.calgoncarbon.com), or call 1-800-4-CARBON to learn more about our complete range of products and services, and local contact information.



## Why are Activated Carbons Different?

As mentioned earlier, because activated carbons can be made from any carbonaceous raw material, differences will exist in the finished product as shown in Table 1. Domestically, most carbons are manufactured from coals. These include, in order of decreasing quality, metallurgical-grade bituminous coal, a lower ranked sub-bituminous coal and lignite. The base raw material and pre-treatment steps prior to activation can affect many of the physical and activity characteristics of activated carbon. These different properties make some carbons better suited than others for specific applications.

Carbon made from lignite tend to have a large pore diameter (higher molasses number ) which makes them better suited for the removal of large color body molecules from liquids. Bituminous coal activated carbons have a broad range of pore diameters. Since these carbons have both a fine and wide pore diameter, they are well-suited for general de-chlorination and the removal of a wider variety of organic chemical contaminants from water, including the larger color bodies.

Some physical properties can be important in determining which carbon is best suited for a specific application. For instance, the abrasion resistance of activated carbons can be important if the carbon is to be used in an application where frequent backwashing will be required. Generally, coal-based activated carbons show an increase in the abrasion number (therefore, increased abrasion resistance when going from the softer lignite carbons to the bituminous coal carbons (Table 1).

Density can also be a major consideration for specific applications. As Table 1 shows, the densities of activated carbons also vary with the raw material. Fewer pounds of carbon with a low density will fit into a given container as compared to a carbon with a high density. This is significant because, while a container may require less carbon weight of a low density carbon to make a volume fill, its contaminant removal performance may be severely reduced as compared to a higher density carbon.

The concept of volume activity then becomes important when evaluating carbons. A simple calculation for determining the volume activity of carbons is to multiply the bulk density by the Iodine number. Thus, two containers having the same volume with carbons having the same Iodine activity (measured in milligrams Iodine per gram carbon) but different densities will have significantly different total surface areas (volume activity) available for adsorption.

Table 1 presents volume activity data for carbons made from three different raw materials. These volume activities have been calculated for a standard volume of one cubic foot. Differences in volume activity are evident when Iodine activities are the same but bulk densities are different (bituminous vs. sub-bituminous), and even more dramatic when both Iodine activities and bulk densities are different (bituminous vs. lignite).

Ash content can play an important role in home water filter applications. Carbons made from high ash content coals, such as sub-bituminous or lignite, generally have some sort of chemical acid treatment step to reduce the inorganic constituents which cannot be activated. Although rinsed, acid residuals can remain with the carbon after treatment. Table 1 shows the high phosphorus level on sub-bituminous-based activated carbon as a result of phosphoric acid pretreatment. These residuals can sometimes be released during use and combined with metal ions in water to form magnesium or calcium precipitates (e.g. magnesium phosphate, calcium phosphate). When this happens, cloudy water can be produced.

## Major Considerations for POU Treatment Design

Now that we understand the properties of activated carbon, how it works and how carbons are different, let's look at how carbon selection and operating conditions affect the performance of a treatment device.

The particle size of carbon affects how any POU treatment system will perform. The smaller the particle size of the carbon, the faster the rate of removal, whether by adsorption or chemical reaction, because the contaminant has less distance to go to reach the pores in the center of the carbon particle. The faster the rate of adsorption, the better the POU system will perform. To illustrate the particle size effect on performance, let's look at how an 8x30 mesh carbon resized to 12x40, 20x40 and 20x50 mesh performs in a de-chlorination study.



Calgon Carbon Corporation  
P.O. Box 717  
Pittsburgh, Pa 15230

Chemviron Carbon  
Zoning Industriel C  
B-7181 Feluy, Belgium

**Chemviron  
Carbon**

An influent chlorine concentration of approximately 5 ppm and a surface loading rate in 1-inch columns of 24 gpm/ft<sup>2</sup> was used (Figure 2) in the study. This gave an empty bed contact time of 10 seconds. Four columns were run in a parallel mode using the same feed water and the same amount of activated carbon packed in 1-inch columns. In Figure 2 the data shows that the column with the smallest particle size, the 20x50 mesh, was able to maintain the treatment objective of 1 ppm through the entire 60 hour experiment, whereas the 8x30 mesh product broke through the treatment objective after 5 hours. Although the smaller particle size carbon performed better at the high flow rate, the potential for pressure drop problems must be considered.

Another major operating variable which impacts adsorption is the concentration of the adsorbate relative to its solubility. Adsorption capacity increases at higher concentrations of the adsorbate. Still, even at the lower contaminant concentrations found in drinking water, a significant carbon capacity remains to provide effective removal of these compounds.

Other operating factors which can influence carbon performance are temperature and pH. While adsorption capacity can increase with decreasing stream temperatures, the temperature effect is minimal. However, practical operation of POU treatment systems is recommended at ambient or colder temperatures. The pH of the water is important from the standpoint of its effect on solubility of the particular contaminant. Some organic compounds can exist in a more disassociated, polar form due to a pH shift, and would be less amenable to adsorption because of their increased solubility.

In summation, the two most important operating conditions for water treatment systems are flow rate of the water stream and concentration of the adsorbate relative to its solubility in water. As a general rule, lower flow rates allow a greater contact time with a unit volume of carbon, thereby improving the ability of the available carbon pore surfaces to attract and adsorb molecules. High flow rates can result in inefficient use of a carbon's capacity by not allowing the time for an adsorbate to migrate through the carbon pore to adsorption surfaces; however, it may be possible to compensate for high flow rates with a smaller particle size.

## Conclusion

There are several considerations involved in the selection of an activated carbon for POU treatment. A typical laundry list of items for evaluation includes the type of contaminant to be removed (chlorine, general taste and odor, color bodies, specific organics, or all of these), the treatment objective, handling requirements and purity of the effluent water.

Treatment devices with short contact times require the smallest particle size carbon practical for efficient use in contaminant removal. Also, carbons with a higher density and a high Iodine number allow more pounds of carbon to be placed in a given volume unit and provide more total surface area (volume activity) in any given container. If the system is to be back-washable, the use of a high abrasion number carbon is recommended so that the carbon will not break up during backwashing. Finally, it is important to know how your carbon is produced, the raw materials used and whether or not the raw material has been chemically treated which might affect the quality of the water coming out of the treatment unit.

By Robert T. DeThora and Anthony F. Mazzoni



Visit our website at [www.calgoncarbon.com](http://www.calgoncarbon.com), or call 1-800-4-CARBON to learn more about our complete range of products and services, and local contact information.

**Chemviron  
Carbon**