



GZA GEOENVIRONMENTAL, INC.
ENGINEERS AND SCIENTISTS

530 BROADWAY
 PROVIDENCE, RHODE ISLAND 02909
 (401) 421-4140
 FAX (401) 751-8613

LETTER OF TRANSMITTAL

TO Rhode Island Department of Environmental Management
 Office of Water Resources, RIPDES Program
 295 Promenade Street
 Providence, Rhode Island 02903

DATE:	11/13/09	JOB NO.	43654.00
ATTENTION:	Mr. Brian D. LaFaille		
RE:	Request for Remediation General Permit Notice of Intent Treatment & Discharge of Stormwater from Former Gas Holders Former Tidewater Facility Pawtucket, Rhode Island		

WE ARE SENDING YOU

- | | | |
|---|---------------------------------------|---|
| <input type="checkbox"/> Shop Drawings | <input type="checkbox"/> Reports | <input type="checkbox"/> Under Separate cover via _____ the following items. |
| <input type="checkbox"/> Copy of Letter | <input type="checkbox"/> Prints | <input type="checkbox"/> Plans <input type="checkbox"/> Samples <input type="checkbox"/> Specifications |
| | <input type="checkbox"/> Change Order | <input checked="" type="checkbox"/> Other: Pc |

HOW SHIPPED

- Overnight Courier Regular Mail Hand Delivered / Picked Up

COPIES	DATE	NO.	DESCRIPTION
1	November 2009		Remediation General Permit Notice of Intent-Former Tidewater Facility

THESE ARE TRANSMITTED as checked below:

- | | | |
|--|---|---|
| <input checked="" type="checkbox"/> For approval | <input type="checkbox"/> Approved as submitted | <input type="checkbox"/> Resubmit for approval |
| <input checked="" type="checkbox"/> For your use | <input type="checkbox"/> Approved as noted | <input type="checkbox"/> Submit for distribution |
| <input type="checkbox"/> As requested | <input type="checkbox"/> Returned for corrections | <input type="checkbox"/> Return corrected prints |
| <input type="checkbox"/> For review and comment | <input type="checkbox"/> Other: _____ | <input type="checkbox"/> PRINTS RETURNED AFTER LOAN TO US |
| <input type="checkbox"/> FOR BIDS DUE _____ | No. _____ | |

REMARKS:

PRINT NAME: Mario Costa
 SIGNATURE: [Signature]
 DATE: 11/13/09

cc: Michele Leone, National Grid

Signed Margaret Kilpatrick, GZA, Senior Project Manager

November 12, 2009
File No. 43654.00-C



Mr. Brian D. LaFaille
Rhode Island Department of Environmental Management
Office of Water Resources, RIPDES Program
235 Promenade Street
Providence, Rhode Island 02908-5767

Re: **Request for Remediation General Permit
Notice of Intent**
Treatment and Discharge of Stormwater from Former Gas Holders
Former Tidewater Facility
Tidewater Street
Pawtucket, Rhode Island

530 Broadway
Providence
Rhode Island
02909
401-421-4140
FAX 401-751-8613
www.gza.net

Dear Mr. LaFaille:

On behalf of our Client, The Narragansett Electric Company d/b/a National Grid (National Grid), GZA GeoEnvironmental, Inc. (GZA) has prepared the attached Notice of Intent (NOI) for a Rhode Island Pollutant Discharge Elimination System (RIPDES) General Permit for the treatment and discharge to the Seekonk River of stormwater accumulated in former Gas Holder Nos. 7 and 8 at the Former Tidewater facility located in Pawtucket, Rhode Island (herein referred to as the "Site"). The completed NOI is included in the attached Appendix A.

In addition to this letter and its attachments, we have enclosed the required permit fee of \$400.00.

BACKGROUND

This Site was the location of the former Tidewater Manufactured Gas Plant (MGP) and the Pawtucket No. 1 Power Station. The majority of the Site is currently vacant with the exception of an active natural gas regulating station, and active switching and electrical substations, both owned and operated by National Grid. National Grid acquired the electrical side of the Site in May 2000. More recently, in August 2006, National Grid acquired the majority of the assets of New England Gas Company which included the gas side of the Site. National Grid is currently completing a *Site Investigation* for the entire Site (both the electric and gas portions), and has been assigned case number 95-022 by the Rhode Island Department of Environmental Management (RIDEM), Office of Waste Management (Contact: Joseph Martella).

The Site is located on the west side of the Seekonk River in Pawtucket, Rhode Island. A *Site Locus Plan* is provided as Figure 1. The northern portion of the Site is accessed from Tidewater Street, and is further identified by the City of Pawtucket Tax Assessor's Office as Plat 54B, Lot 826 and Plat 65B, Lot 662. The Tidewater MGP began operation in the late 1800s and produced coal and water gas until 1954. After 1954, the MGP produced oil gas until 1968 when it was decommissioned. After 1968, Gas Holders Nos. 7 and 8, which are located on the northwestern portion of the Site near the intersection of Tidewater and Taft Streets, were used to store natural gas until the 1980s.



The Seekonk River has been designated by the Coastal Resource Management Council (CRMC) as Type 4 waters, defined as multipurpose waters and Type 6 waters, industrial waterfronts and commercial navigation channels. The RIDEM Office of Water Resources has classified the Seekonk River as SB1 {a} waters. These waters are designated for primary and secondary contact recreational activities and fish and wildlife habitat.

PROPOSED DISCHARGE

The purpose of the treatment and discharge of the accumulated stormwater in the former gas holders is to prepare them for subsequent demolition and removal from the Site. Based on observations made by GZA on August 26, 2009 and previous observations made by others, it is estimated that these two holders currently contain a total of approximately 8,025,000 gallons of stormwater above a sludge layer. The plan is to treat and discharge accumulated stormwater and other liquids in two primary phases:

- Phase 1: the stormwater accumulated to a depth of 2-feet above the sludge layer in each holder will be treated and discharged; and
- Phase 2: the remaining stormwater above the sludge layer and other waters generated during tank dismantling activities, primarily sludge dewatering, which are currently estimated at approximately 1 to 2 million gallons, will subsequently be treated and discharged to the Seekonk River.

Both phases will use the same treatment train and adhere to the same monitoring and analysis schedules and discharge criteria. Based on an average flow rate of approximately 80 gallons per minute (gpm), we expect it will take approximately 2 to 3 months to complete Phase 1. Phase 2 will be initiated subsequent to Phase 1. The actual tank dismantling activities are currently expected to take approximately 3 to 4 months to complete. Depending on the scheduling of Phase 1 and 2, there may be an interim duration between activities when additional stormwater collected in the tanks will be treated and discharged in accordance with the requirements of this General Permit. As indicated on the attached NOI, we currently anticipate Phase I and II will be complete in a total of 12 months.

GAS HOLDER SAMPLING AND ANALYSES

GZA collected stormwater quality samples from the holders on August 26, 2009. This sampling included vertical profiling from each holder to further assess the quality of the stormwater at select water depths. Three samples were collected from each gas holder using a submersible pump and the samples were analyzed for parameters listed by the RIDEM RIPDES Remediation General Permit Discharge Category E Criteria (i.e., Sites containing volatile organic compounds and other contaminants discharging to SA and SB receiving waters). In addition to the criteria listed above, laboratory samples were also collected to assist in treatment design, including hardness, dissolved metals, sulfate, ferrous iron and ferric iron. Water depth, sampling zones, temperature and pH data collected during the August 2009 sampling, as well as a list of laboratory parameters and methods, are included in Table 1.

The results of the August 2009 laboratory analyses have been summarized and compared with the above listed RIPDES criteria in Table 2. A summary of additional sampling conducted by GZA in June 2009 and VHB in March 2006 is presented in Table 3. This data, when compared to the RIPDES criteria suggests treatment will be necessary to address the following constituents: benzene, total BTEX, naphthalene, mercury, copper, lead, iron, and total cyanide. No VOCs or



SVOCs were detected above the method detection limit in Gas Holder 8 during either sampling round. It is likely that the VOCs and SVOCs detected in Gas Holder 7 are the result of water disturbance/agitation and similar levels and constituents are likely present in Gas Holder 8. For the purpose of designing the treatment system (see below), we have conservatively assumed the VOC and SVOC levels detected in Gas Holder 7 are representative of what will be observed during discharge from both holders.

TREATMENT SYSTEM DESIGN

Based on the quality of the stormwater contained within the holders and the RIPDES permit limits, a treatment system comprised of the following will be constructed at the Site. The approximate location of the treatment system is shown on Figure 3. Figure 4 shows a schematic of the treatment works. Additional information on certain of the treatment system components is provided in Appendix B.

1. Water from the individual gas holders will be pumped from the holders using a submersible pump into an approximately 21,000-gallon settling or fractionation tank (frac) for particulate settling and flow equalization. As shown on Figure 4, the discharge from the gas holder to the primary settling tank will be equipped with a vacuum breaker, a gate valve for flow control, a check valve and a flow meter/totalizer.
2. From the flow equalization tank, water will be processed through a treatment system designed for 100 gpm which will consist of the following:
 - Four 25-micron pre-filters in parallel for removal of suspended solids and iron precipitate;
 - Four 1,000-pound granular activated carbon (GAC) absorbers for VOC removal. Based on the VOC levels detected within the tanks, the anticipated flow rate, and the size of the vessels, we anticipate “breakthrough” on the first vessels will likely occur after approximately 30 to 35 days of treatment. In addition to the permit required effluent sampling, mid-point samples after the primary GAC vessels will be collected and analyzed for VOCs on an approximately bi-weekly basis to evaluate potential breakthrough. The pressure of the vessels will also be monitored as an additional measure of potential breakthrough due to fouling. Breakthrough calculations for the GAC units are provided in Appendix C.
 - A 1-micron high purity cartridge filter; and
 - Ion exchange filters consisting of IX filter vessels with a mixed bed ion exchange resin (vessels will contain a total of 100 cubic feet of cation and 100 cubic feet of anion) for metals and cyanide removal. Based on the observed concentrations of the metals and cyanide, the flow rate, and a resin usage rate of 1 pound for every pound of metals, we expect the ion exchange units will require change out after approximately 70 days of operation. Similar to the GAC, mid-point samples after the primary unit will be collected and analyzed for metals and cyanide on an approximately a bi-weekly basis to evaluate potential breakthrough. Breakthrough calculations for the ion exchange units are provided in Appendix C. The pressure of the vessels will also be monitored as an additional measure of potential breakthrough.



3. An approximately 21,000 gallon secondary settling tank. Treated effluent will be discharged to the Seekonk River via gravity flow from this tank. The discharge line will be equipped with a gate valve followed by a flow meter/totalizer. Readings from this flow meter will be used to report the discharge rate and volume to the Seekonk River. In addition, this tank will be equipped with a submersible pump with float controls. In the event that an exceedance of the permit is identified through analytical sampling, the effluent gate valve will be immediately closed down and the submersible pump will be used to circulate the water contents from the secondary frac tank to the primary frac tank as indicated on Figure 4.
4. As shown on Figure 3, a six-inch diameter discharge line will be extended in a westerly orientation towards the Seekonk River. The discharge outlet will be designed to terminate in an area of the bank currently constructed of large rip rap stone at approximately the mean high water line. It is anticipated that the 6-inch discharge line will transition to a 6-inch header equipped with five individual lateral lines, with total flows being distributed to the river via these individual pipes. The discharge outlet will be designed to minimize erosion and sedimentation of the riverbank and riverbed sediment.
5. As shown on Figures 3 and 4, the treatment system components will be set within an approximately 4,500 square foot secondary containment system consisting of 30 mil polyethylene covered with pea stone. Three sides will be equipped with an earthen berm covered with polyethylene and secured using sand bags. We estimate the secondary containment system will hold approximately 32,000 gallons of water. The fourth (upgradient) side will be left open for vehicle and maintenance access.

The treatment system will be designed hydraulically for a maximum flow rate of 100 gpm and will be equipped with integrated controls to allow for continuous, unmanned operation. The control system will be equipped with an auto-dialer unit that will alert the operator in the event of an alarm or shutdown condition. System controls will include float switches and pressure sensors. Sampling ports will be placed before, between and after each filter, GAC and IX filter vessel, and pressure gauges will be installed on each filter and vessel. These pressure sensors will be monitored to assess the need for maintenance and/or filter/media replacement during operations.

As the system is expected to be operated when the air temperature drops below freezing, the GAC filters and certain transfer lines will be housed within a heated trailer unit. Components not housed within the trailer may be insulated and/or otherwise protected using heat tape as needed to prevent potential freezing.

ANTICIPATED MONITORING PROGRAM

It is our understanding that since the receiving water is classified as SB1a, RIDEM regulations under the RIPDES Remediation General Permit 2008 - Discharge Category E will require monitoring of the treatment system discharge two times per month for the constituents that are known to be present (VOCs, metals and cyanide constituents) and annually for the compounds on the Discharge Category E list that are not known to be Site constituents. All sampling and testing will be conducted in accordance with Table 14 of Section D "Effluent Limitations and Monitoring Requirements" of the RIPDES Remediation General Permit 2008.

SCHEDULE

Depending primarily on the timeframe required to extend existing electrical power to the area of the gas holders, we currently plan to initiate this treatment and discharge in early to mid January 2010. We trust this allows adequate time for processing this application.



We trust this information presented herein and in the attached satisfies the requirements of the NOI for a RIPDES General Permit. Please feel free to contact Stephen Andrus at 401-421-4140 should you have any questions or require any additional information.

Very truly yours,

GZA GEOENVIRONMENTAL, INC.

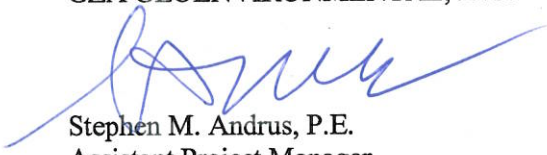
Stephen M. Andrus, P.E.
Assistant Project Manager

Margaret S. Kilpatrick, P.E.
Senior Project Manager

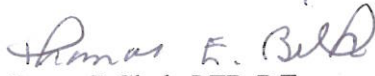
for 
James J. Clark, LEP, P.E.
Principal

MSK/JJS:tja

- Attachments: Table 1 – Summary of August 29, 2009 Gas Holder Sampling Field Data and Laboratory Analysis
Table 2 - Summary of August 29, 2009 Gas Holder Analytical Results
Table 3 - Summary of Historical Gas Holder Analytical Results
Figure 1 - *Locus Plan*
Figure 2 – *Existing Conditions Site Plan*
Figure 3 – *Water Treatment System and Discharge Location*
Figure 4 - *Treatment Schematic & System Components Details*
Appendix A – NOI
Appendix B - Treatment System Components
Appendix C - Breakthrough Calculations
Appendix D - Laboratory Data Sheets
Appendix E – Copy of Application Fee (Check No. 202717)

cc: Michele Leone – National Grid

TABLES

TABLE 1
SUMMARY OF AUGUST 26, 2009 GAS HOLDER SAMPLING FIELD DATA AND LABORATORY ANALYSIS

Tidewater Facility
Pawtucket, Rhode island

Gas Holder #7				
Depth to Water Surface		13.4	Feet	
Depth to Bottom (Assumed Sludge Surface)		32.8	Feet	
Height of Water Column		19.4	Feet	
Approximate Tank Freeboard		11.4	Feet	
Sample	Sampling Zone (Below Water Surface)	Sampling Depth (Below Water Surface)	pH	Temperature
	(Feet)	(Feet)	(SU)	°C
S-1	0 to 6	3	5.45	27.7
S-2	6 to 12	9	5.51	25.6
S-3	12 to 19.4	15	5.49	24.2
Gas Holder #8				
Depth to Water Surface		3.3	Feet	
Depth to Bottom (Assumed Sludge Surface)		37.2	Feet	
Height of Water Column		33.9	Feet	
Approximate Tank Freeboard		0.3	Feet	
Sample	Sampling Zone (Below Water Surface)	Sampling Depth Below Water Surface	pH	Temperature
	(Feet)	(Feet)	(SU)	°C
S-1	0 to 11	5.5	5.1	26.4
S-2	11 to 22	16.5	5.49	21.3
S-3	22 to 33.9	27.5	5.48	16.8

Analytical Summary		
Analysis	Method	Analytical Laboratory
VOCs	EPA 8260B	GZA Laboratory Services
PAHs	EPA 8270D	GZA Laboratory Services
TPH	Mod. EPA 8100	GZA Laboratory Services
Metals ³ Total	EPA 6010B	GZA Laboratory Services
Metals ³ Dissolved	EPA 6010B	GZA Laboratory Services
Mercury Total	EPA 7470A	GZA Laboratory Services
Mercury Dissolved	EPA 7470A	GZA Laboratory Services
Ferrous Iron	SM 3500Fe,B.4.c	Rhode Island Analytical Laboratory
Ferric Iron	Calculation	GZA Laboratory Services
Hardness	200.7	GZA Laboratory Services
TSS	160.2	Rhode Island Analytical Laboratory
Cyanide Total	EPA 9010	Rhode Island Analytical Laboratory
Cyanide Free	EPA 9010	Rhode Island Analytical Laboratory
Sulfate	EPA 300.0	GZA Laboratory Services
pH	Field Parameter	GZA Field Personnel
Temperature	Field Parameter	GZA Field Personnel

1. Water depth measured with a Slope Indicator Water Level Meter. Datum was top of tank at sampling location.
2. pH and temperature readings taken with a YSI pH and Temperature meter, Model 60.
3. Metals include Arsenic, Antimony, Cadmium, Chromium, Copper, Lead, Nickel, Selenium, Silver, Iron, Manganese and Zinc

TABLE 2
SUMMARY OF AUGUST 26, 2009 GAS HOLDER ANALYTICAL RESULTS

Tidewater Facility
Pawtucket, Rhode Island

Constituent	Units	RIDEM RIPDES Remediation Permit Category E Discharge to SA and SB Waters		GH-7 S-1		GH-7 S-2		GH-7 S-3		GH-8 S-1		GH-8 S-2		GH-8 S-3	
		Acute	Chronic	0 to 6-feet below water surface 8/26/2009		6 to 12-feet below water surface 8/26/2009		12 to 18-feet below water surface 8/26/2009		0 to 11-feet below water surface 8/26/2009		11 to 22-feet below water surface 8/26/2009		22 to 33-feet below water surface 8/26/2009	
				Result	RL	Result	RL	Result	RL	Result	RL	Result	RL	Result	RL
EPA 8260 VOLATILE ORGANICS															
Benzene	µg/L	5	5	9.5	1	8.6	1	3.8	1	<	1	<	1	<	1
Toluene	µg/L	12,000	NE	78	1	86	1	83	1	<	1	<	1	<	1
Ethylbenzene	µg/L	1,680	NE	21	1	27	1	26	1	<	1	<	1	<	1
m&p-Xylene	µg/L	NE	NE	150	2	160	2	160	2	<	2	<	2	<	2
o-Xylene	µg/L	NE	NE	62	1	67	1	69	1	<	1	<	1	<	1
Total Xylenes	µg/L	NE	NE	212	--	227	--	229	--	ND	--	ND	--	ND	--
Total BTEX	µg/L	100	100	320.5	--	348.6	--	341.8	--	ND	--	ND	--	ND	--
Styrene	µg/L	NE	NE	8.1	1	8.9	1	8.4	1	<	1	<	1	<	1
Isopropylbenzene	µg/L	NE	NE	2.2	1	2.6	1	2.7	1	<	1	<	1	<	1
1,3,5-Trimethylbenzene	µg/L	NE	NE	23	1	25	1	26	1	<	1	<	1	<	1
1,2,4-Trimethylbenzene	µg/L	NE	NE	51	1	56	1	59	1	<	1	<	1	<	1
p-Isopropyltoluene	µg/L	NE	NE	1.4	1	1.5	1	1.6	1	<	1	<	1	<	1
Naphthalene	µg/L	NE	20	37	2	47	2	48	2	<	2	<	2	<	2
EPA 8270 PAHS BY GCMS															
Naphthalene	µg/L	NE	20	11	2	15	2	17	2	<	2	<	2	<	2
2-Methylnaphthalene	µg/L	NE	NE	<	2	<	2	2.6	2	<	2	<	2	<	2
Mod. EPA 8100 TOTAL PETROLEUM HYDROCARBON															
Hydrocarbon Content	mg/L	NE	1	0.81	0.2	0.84	0.2	0.76	0.2	0.28	0.2	0.34	0.2	0.33	0.2
EPA 6010B METALS															
Copper	mg/L	0.00298	0.00462	0.016	0.015	0.016	0.015	0.016	0.015	0.016	0.015	0.015	0.015	0.015	0.015
Lead	mg/L	0.00681	0.1766	0.024	0.01	0.026	0.01	0.023	0.01	0.028	0.01	0.029	0.01	0.029	0.01
Iron	mg/L	NE	1	1.7	0.025	1.8	0.025	1.7	0.025	0.27	0.025	0.27	0.025	0.3	0.025
Manganese	mg/L	NE	NE	0.27	0.005	0.27	0.005	0.26	0.005	0.17	0.005	0.17	0.005	0.17	0.005
Zinc	mg/L	0.0685	0.07611	0.016	0.01	0.015	0.01	0.019	0.01	0.026	0.01	0.026	0.01	0.028	0.01
EPA 6010B DISSOLVED METALS															
Copper	mg/L	0.00298	0.00462	0.016	0.015	0.016	0.015	0.016	0.015	0.016	0.015	0.015	0.015	<	0.015
Lead	mg/L	0.00681	0.1766	0.015	0.01	0.01	0.01	<	0.01	0.024	0.01	0.026	0.01	0.026	0.01
Iron	mg/L	NE	1	0.29	0.025	0.54	0.025	0.14	0.025	0.045	0.025	0.071	0.025	0.057	0.025
Manganese	mg/L	NE	NE	0.27	0.005	0.27	0.005	0.26	0.005	0.17	0.005	0.17	0.005	0.17	0.005
Zinc	mg/L	0.0685	0.07611	0.015	0.01	0.017	0.01	0.012	0.01	0.031	0.01	0.031	0.01	0.031	0.01
EPA 300.0 ANIONS - ION CHROMATOGRAPHY															
Sulfate	mg/L	NE	NE	<	0.6	<	0.6	<	0.6	0.9	0.6	0.89	0.6	0.97	0.6
Ferric Iron (HACH)	mg/L	NE	NE	1.7		1.8		1.7		0.27		0.27		0.3	
HARDNESS (EPA 200.7)	mg (CaCO ₃)/L	NE	NE	1.6		1.6		1.6		1.3		1.2		1.4	
Calcium	mg/L	NE	NE	0.38	0.025	0.45	0.025	0.41	0.025	0.31	0.025	0.29	0.025	0.36	0.025
Magnesium	mg/L	NE	NE	0.15	0.025	0.14	0.025	0.14	0.025	0.12	0.025	0.12	0.025	0.12	0.025
SUBCONTRACTED ANALYTES															
SM-2540D Total Suspended Solids	mg/L	30	NE	2	2	<	2	<	2	<	2	<	2	<	2
SM-4500CN-C E Total Cyanide	mg/L	0.0008	0.0008	0.06	0.01	0.04	0.01	0.06	0.01	<	0.01	0.04	0.04	0.04	0.01

UNDETECTED METALS	UNIT	RL
Arsenic	mg/L	0.01
Antimony	mg/L	0.025
Cadmium	mg/L	0.005
Chromium	mg/L	0.005
Nickel	mg/L	0.01
Selenium	mg/L	0.025
Silver	mg/L	0.005
Mercury	mg/L	0.004
Ferrous Iron	mg/L	0.4
Free Cyanide	mg/L	0.01

ND = Non-detect

NE = No limits established

Indicates detected constituent concentration above the RIDEM RIPDES Remediation Permit Category E Discharge to SA and SB Waters

**TABLE 3
SUMMARY OF HISTORICAL GAS HOLDER ANALYTICAL RESULTS**

*Tidewater Facility
Pawtucket, Rhode Island*

Constituent	Units	RIDEM RIPDES Remediation Permit Category E Discharge to SA and SB Waters		6/2/2009 (VHB) Gasholder 7	6/17/2009 (GZA) Gasholder 8	3/31/2006 (VHB) Gasholder 7	3/31/2006 (VHB) Gasholder 7	3/31/2006 (VHB) Gasholder 8	3/31/2006 (VHB) Gasholder 8
		Acute	Chronic			1-4' below surface	15-20' below surface	1-4' below surface	15-20' below surface
VOCs, SVOCs, PAHs									
1,2,4-Trimethylbenzene	µg/L	NE	NE	57.3	<1	70.4	75.6	<1	<1
1,3,5-Trimethylbenzene	µg/L	NE	NE	21.2	<1	25.8	26.9	<1	<1
4-Isopropyltoluene	µg/L	NE	NE	1.2	<1	NT	NT	NT	NT
Benzene	µg/L	5	5	8.9	29	36.4	45.7	<1	<1
Ethylbenzene	µg/L	1,680	NE	26.2	1	31.3	37.3	<1	<1
Isopropylbenzene	µg/L	NE	NE	1.3	<1	NT	NT	NT	NT
Napthalene (8260B)	µg/L	NE	20	243	<10	169	222	<1	<1
Styrene	µg/L	NE	NE	NT	NT	<0.01	11.4	<1	<1
Toluene	µg/L	12,000	NE	77.6	7	109	130	<1	<1
Xylenes (total)	µg/L	100	100	232	6	258	302	<3	<3
Napthalene (8270C)	µg/L	NE	20	69	NT	140	147	<10	<10
Total BTEX	µg/L	100	100	345	43	434.7	515	ND	ND
2-Methylnaphthalene	µg/L	NE	NE	15.1	<10	17.6	19	<10	<10
Acenaphthylene	µg/L	1.9	1.9	0.58	<10	NT	NT	NT	NT
Fluoranthene	µg/L	112	NE	0.48	<10	NT	NT	NT	NT
Phenanthrene	µg/L	NE	NE	0.44	<10	NT	NT	NT	NT
Metals									
Mercury	mg/L	0.00012	0.00139	NT	0.0006	NT	NT	NT	NT
Selenium	mg/L	0.5691	0.23246	NT	0.052	NT	NT	NT	NT
Lead	mg/L	0.00681	0.176.6	NT	<0.040	<0.05	<0.05	0.068	0.083
Zinc	mg/L	0.0685	0.07611	NT	<0.020	<0.05	<0.05	<0.05	0.07
OTHER									
TPH	mg/L	NE	1.000	1.48	0.23	1.99	1.86	0.45	0.38
BOD	mg/L	NE	NE	NT	NT	<3	<3	<3	<3
Oil & Grease	mg/L	0.000	0.000	NT	NT	<5	<5	<5	<5
Total Cyanide	mg/L	0.0008	0.0008	NT	NT	<0.05	<0.05	<0.05	0.05
TSS	mg/L	30	NE	NT	NT	<5	<5	<5	<5

NT = Not tested.

ND = Non-detect

NE = No limits established

Indicates detected constituent concentration above the RIDEM RIPDES Remediation Permit Category E Discharge to SA and SB Waters

FIGURES

FORMER TIDEWATER FACILITY TREATMENT AND DISCHARGE SYSTEM FOR STORM WATER IN FORMER GAS HOLDERS PAWTUCKET, RHODE ISLAND NOVEMBER, 2009

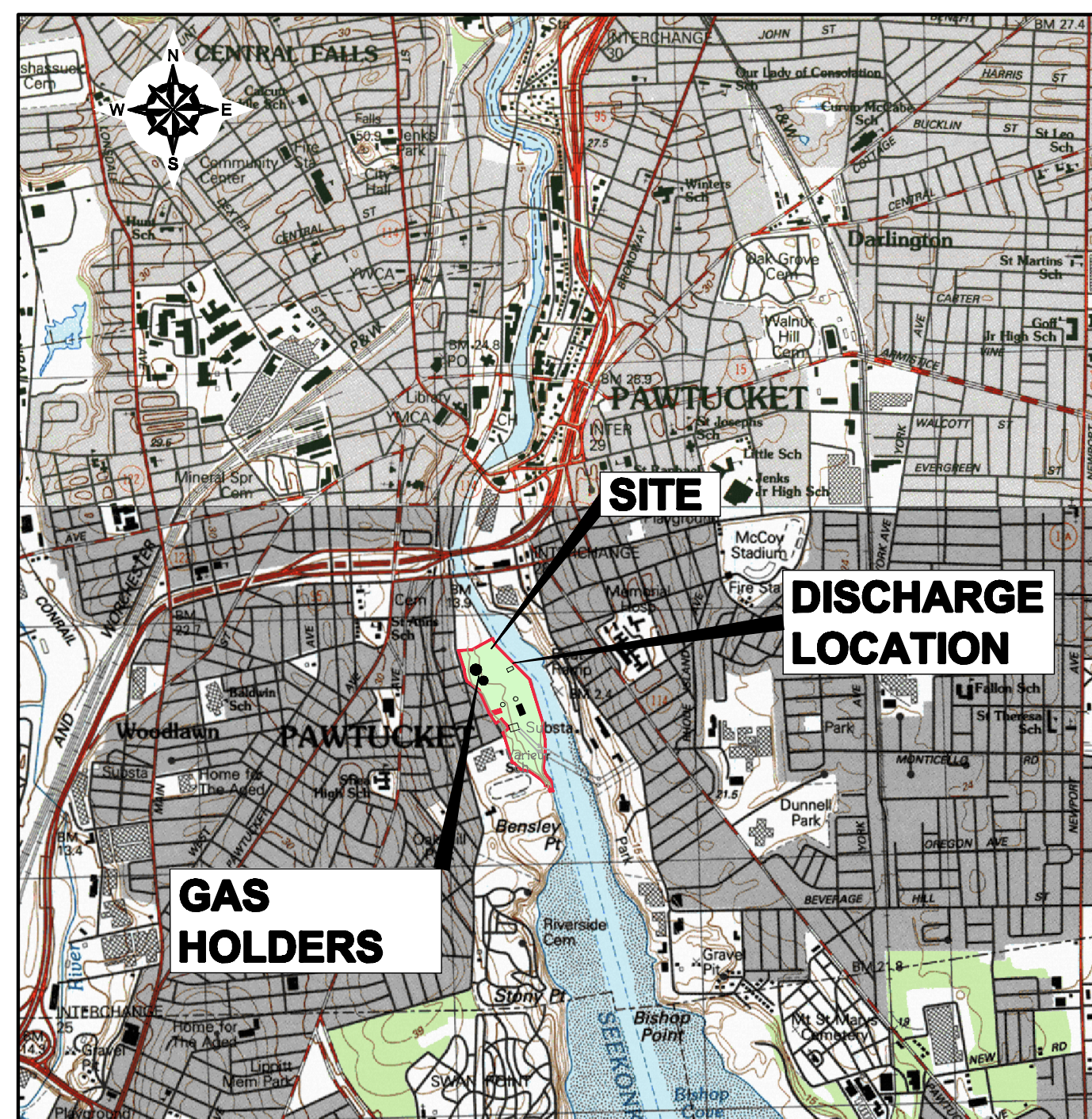

SITE LOCATION PLAN
0 1000 2000 4000 6000
Scale: 1"=2000'

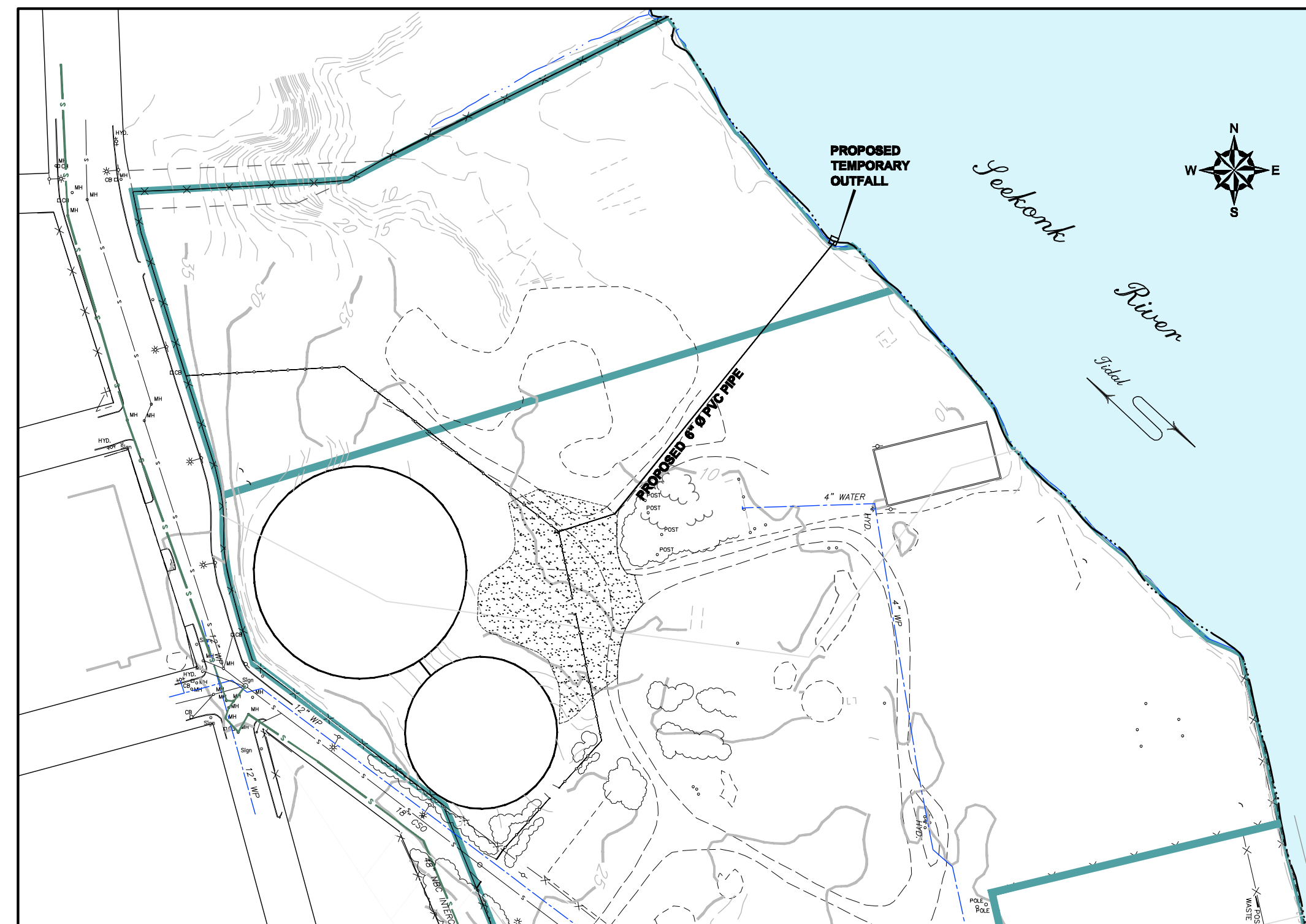

LOCATION MAP
0 50 100 200 300
Scale: 1"=100'

INDEX OF DRAWINGS

- 1 LOCUS PLAN
- 2 EXISTING CONDITIONS SITE PLAN
- 3 WATER TREATMENT SYSTEM & DISCHARGE LOCATION
- 4 TREATMENT SCHEMATIC & SYSTEM COMPONENTS DETAILS

PREPARED FOR: [nationalgrid](http://nationalgrid.com)



GeoEnvironmental, Inc.
Engineers and Scientists
530 Broadway
Providence, Rhode Island 02909

PREPARED BY:

FIGURE

1

PROJECT NO. 43654.00

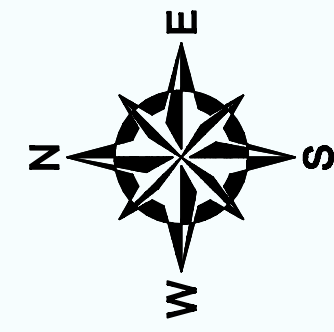

Tidal
Seekonk River

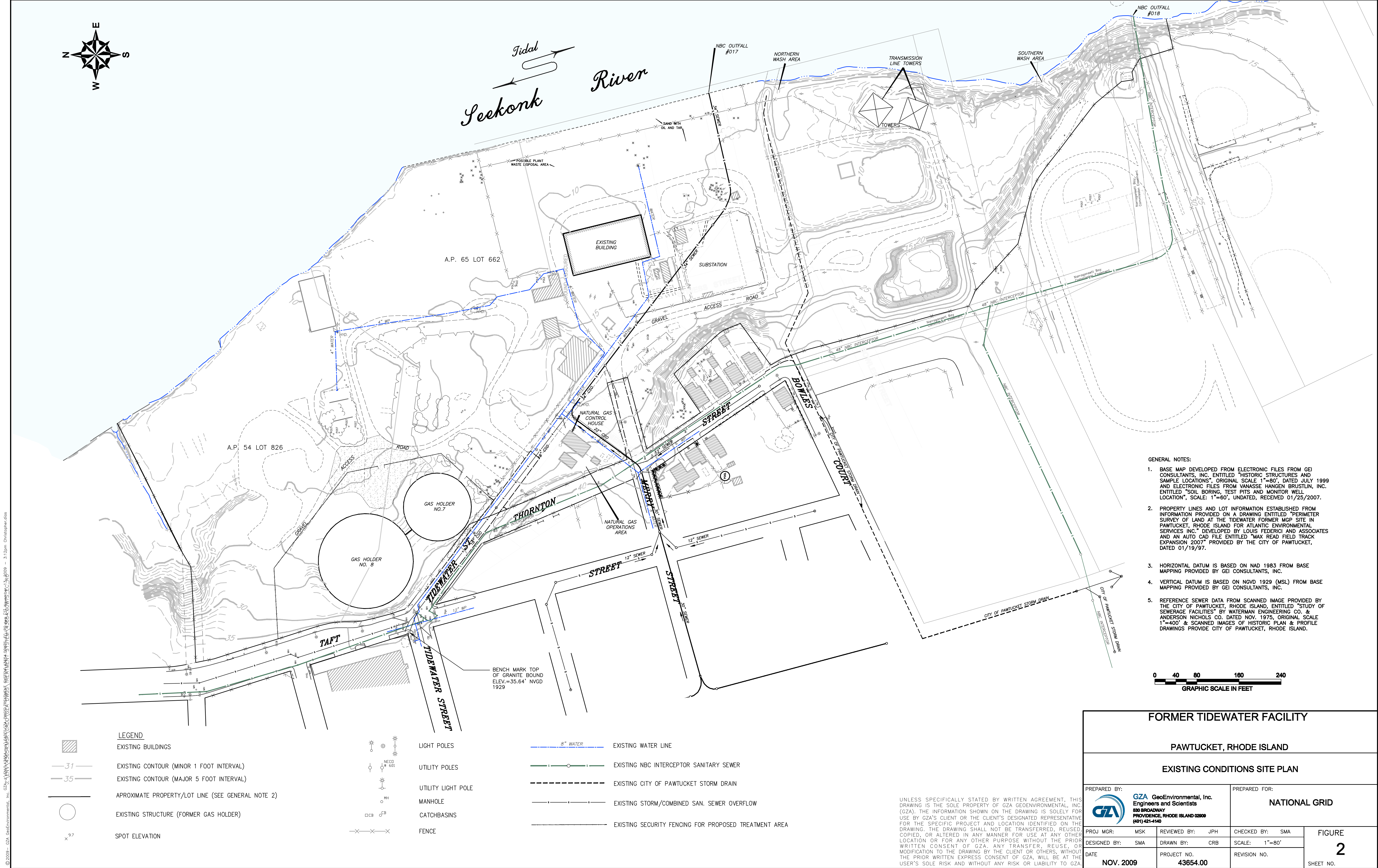

- GENERAL NOTES:
1. BASE MAP DEVELOPED FROM ELECTRONIC FILES FROM GEI CONSULTANTS, INC. ENTITLED "HISTORIC STRUCTURES AND SAMPLE LOCATIONS", ORIGINAL SCALE 1"=80', DATED JULY 1999 AND ELECTRONIC FILES FROM VANASSE HANGEN BRUSTLIN, INC. ENTITLED "SOIL BORING, TEST PITS AND MONITOR WELL LOCATION", SCALE: 1"=60', UNDATED, RECEIVED 01/25/2007.
 2. PROPERTY LINES AND LOT INFORMATION ESTABLISHED FROM INFORMATION PROVIDED ON A DRAWING ENTITLED "PERIMETER SURVEY OF LAND AT THE TIDEWATER FORMER MOP SITE IN PAWTUCKET, RHODE ISLAND FOR ATLANTIC ENVIRONMENTAL SERVICES INC." DEVELOPED BY LOUIS FEDERICI AND ASSOCIATES AND AN AUTO CAD FILE ENTITLED "MAX READ FIELD TRACK EXPANSION 2007" PROVIDED BY THE CITY OF PAWTUCKET, DATED 01/18/97.
 3. HORIZONTAL DATUM IS BASED ON NAD 1983 FROM BASE MAPPING PROVIDED BY GEI CONSULTANTS, INC.
 4. VERTICAL DATUM IS BASED ON NGVD 1929 (MSL) FROM BASE MAPPING PROVIDED BY GEI CONSULTANTS, INC.
 5. REFERENCE SEWER DATA FROM SCANNED IMAGE PROVIDED BY THE CITY OF PAWTUCKET, RHODE ISLAND, ENTITLED "STUDY OF SEWERAGE FACILITIES" BY WATERMAN ENGINEERING CO. & ANDERSON NICHOLS CO. DATED NOV. 1975, ORIGINAL SCALE 1"=400' & SCANNED IMAGES OF HISTORIC PLAN & PROFILE DRAWINGS PROVIDE CITY OF PAWTUCKET, RHODE ISLAND.



LEGEND	
	EXISTING BUILDINGS
	EXISTING CONTOUR (MINOR 1 FOOT INTERVAL)
	EXISTING CONTOUR (MAJOR 5 FOOT INTERVAL)
	APPROXIMATE PROPERTY/LOT LINE (SEE GENERAL NOTE 2)
	EXISTING STRUCTURE (FORMER GAS HOLDER)
	SPOT ELEVATION
	LIGHT POLES
	UTILITY POLES
	UTILITY LIGHT POLE
	MANHOLE
	CATCHBASINS
	FENCE
	8" WATER EXISTING WATER LINE
	EXISTING NBC INTERCEPTOR SANITARY SEWER
	EXISTING CITY OF PAWTUCKET STORM DRAIN
	EXISTING STORM/COMBINED SAN. SEWER OVERFLOW
	EXISTING SECURITY FENCING FOR PROPOSED TREATMENT AREA

FORMER TIDEWATER FACILITY			
PAWTUCKET, RHODE ISLAND			
EXISTING CONDITIONS SITE PLAN			
PREPARED BY:		PREPARED FOR:	
GZA GeoEnvironmental, Inc. Engineers and Scientists 850 BROADWAY PROVIDENCE, RHODE ISLAND 02909 (401) 421-4140		NATIONAL GRID	
PROJ MGR:	MSK	REVIEWED BY:	JPH
DESIGNED BY:	SMA	CHECKED BY:	SMA
DATE:	NOV. 2009	DRAWN BY:	CRB
		PROJECT NO.:	43654.00
		SCALE:	1"=80'
		REVISION NO.:	
			FIGURE 2 SHEET NO.

UNLESS SPECIFICALLY STATED BY WRITTEN AGREEMENT, THIS DRAWING IS THE SOLE PROPERTY OF GZA GEOENVIRONMENTAL, INC. (GZA). THE INFORMATION SHOWN ON THE DRAWING IS SOLELY FOR USE BY GZA'S CLIENT OR THE CLIENT'S DESIGNATED REPRESENTATIVE FOR THE SPECIFIC PROJECT AND LOCATION IDENTIFIED ON THE DRAWING. THE DRAWING SHALL NOT BE TRANSFERRED, REUSED, COPIED, OR ALTERED IN ANY MANNER FOR USE AT ANY OTHER LOCATION OR FOR ANY OTHER PURPOSE WITHOUT THE PRIOR WRITTEN CONSENT OF GZA. ANY TRANSFER, REUSE, OR MODIFICATION TO THE DRAWING BY THE CLIENT OR OTHERS, WITHOUT THE PRIOR WRITTEN EXPRESS CONSENT OF GZA, WILL BE AT THE USER'S SOLE RISK AND WITHOUT ANY RISK OR LIABILITY TO GZA.

© 2009 - GZA GeoEnvironmental, Inc. 029-15594-0001 (09/08) 11/13/09 11:12 AM Christopher Dias

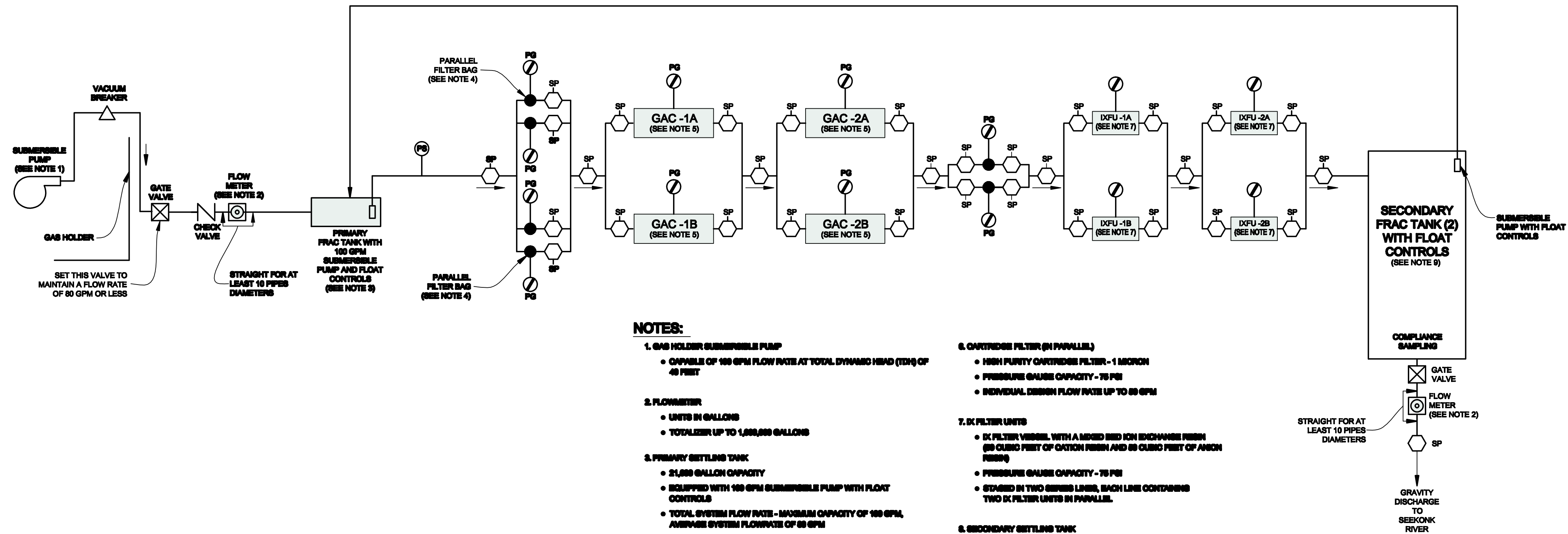

NOTES:

1. GAS HOLDER SUBMERSIBLE PUMP
 - CAPABLE OF 100 GPM FLOW RATE AT TOTAL DYNAMIC HEAD (TDH) OF 40 FEET
2. FLOWMETER
 - UNITS IN GALLONS
 - TOTALIZER UP TO 1,000,000 GALLONS
3. PRIMARY SETTLING TANK
 - 21,000 GALLON CAPACITY
 - EQUIPPED WITH 100 GPM SUBMERSIBLE PUMP WITH FLOAT CONTROLS
 - TOTAL SYSTEM FLOW RATE - MAXIMUM CAPACITY OF 100 GPM, AVERAGE SYSTEM FLOWRATE OF 80 GPM
4. POLYPROPYLENE PRE-FILTER BAGS (IN PARALLEL)
 - FILTER SIZE - 20 MICRON OR LESS
 - PRESSURE CAPACITY - 75 PSI
 - MANIFOLD PIPING HIGH PRESSURE SWITCH
 - INDIVIDUAL DESIGN FLOW RATE UP TO 20 GPM
5. CARBON UNITS
 - HIGH PRESSURE LIQUID PHASE ACTIVATED CARBON ABSORBERS
 - STAGED IN TWO SERIES LINES, EACH LINE CONTAINS TWO GAC UNITS IN PARALLEL.
 - PRESSURE CAPACITY - 75 PSI
 - MANIFOLD PIPING HIGH PRESSURE SWITCH
 - EACH GAC VESSEL CONTAINS 1,000 POUNDS OF CARBON
 - INDIVIDUAL DESIGN FLOW RATE UP TO 20 GPM
6. CARTRIDGE FILTER (IN PARALLEL)
 - HIGH PURITY CARTRIDGE FILTER - 1 MICRON
 - PRESSURE CAPACITY - 75 PSI
 - INDIVIDUAL DESIGN FLOW RATE UP TO 20 GPM
7. DC FILTER UNITS
 - DC FILTER VESSEL WITH A MIXED BED ION EXCHANGE RESIN (80 CUBIC FEET OF CATION RESIN AND 80 CUBIC FEET OF ANION RESIN)
 - PRESSURE CAPACITY - 75 PSI
 - STAGED IN TWO SERIES LINES, EACH LINE CONTAINS TWO DC FILTER UNITS IN PARALLEL.
8. SECONDARY SETTLING TANK
 - 21,000 GALLON CAPACITY
 - GRAVITY DISCHARGE TO SEEKONK RIVER
 - EQUIPPED WITH EFFLUENT GATE VALVE AND (1) 80 GPM SUBMERSIBLE PUMP WITH FLOAT CONTROLS TO ALLOW FOR RECIRCULATION TO PRIMARY SETTLING TANK IN EVENT OF EMERGENCY
9. GENERAL
 - MUST CONFORM TO STATE AND LOCAL BUILDING, PLUMBING AND ELECTRICAL REQUIREMENTS
 - TREATMENT SYSTEM WILL BE WINTERIZED (PLACED IN TEMPORARY STRUCTURE; USE OF HEAT TAPS) TO PREVENT SYSTEM FROM FREEZING
 - SECONDARY CONTAINMENT SYSTEM WILL BE CONSTRUCTED AROUND FOOTPRINT OF TREATMENT SYSTEM
 - SP - SAMPLE PORT
 - PG - PRESSURE GAUGE
 - PS - PRESSURE SWITCH

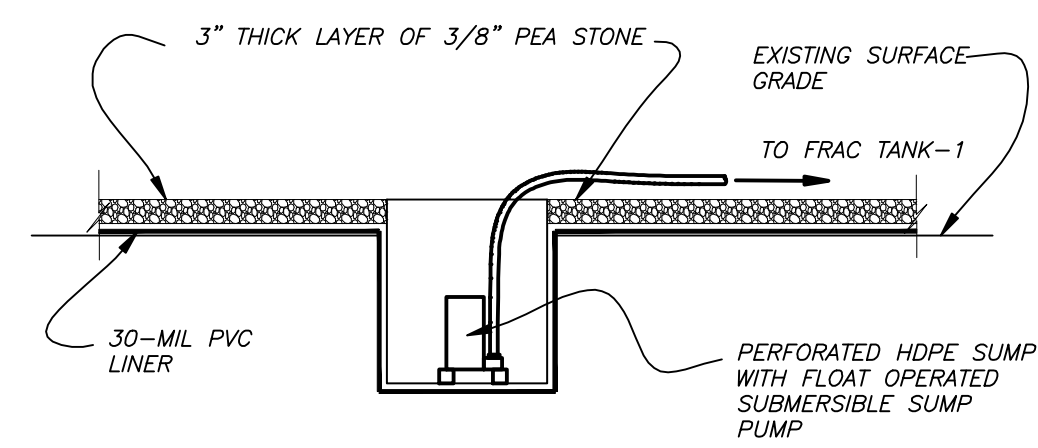

TYPICAL SUMP DETAIL

NOT TO SCALE

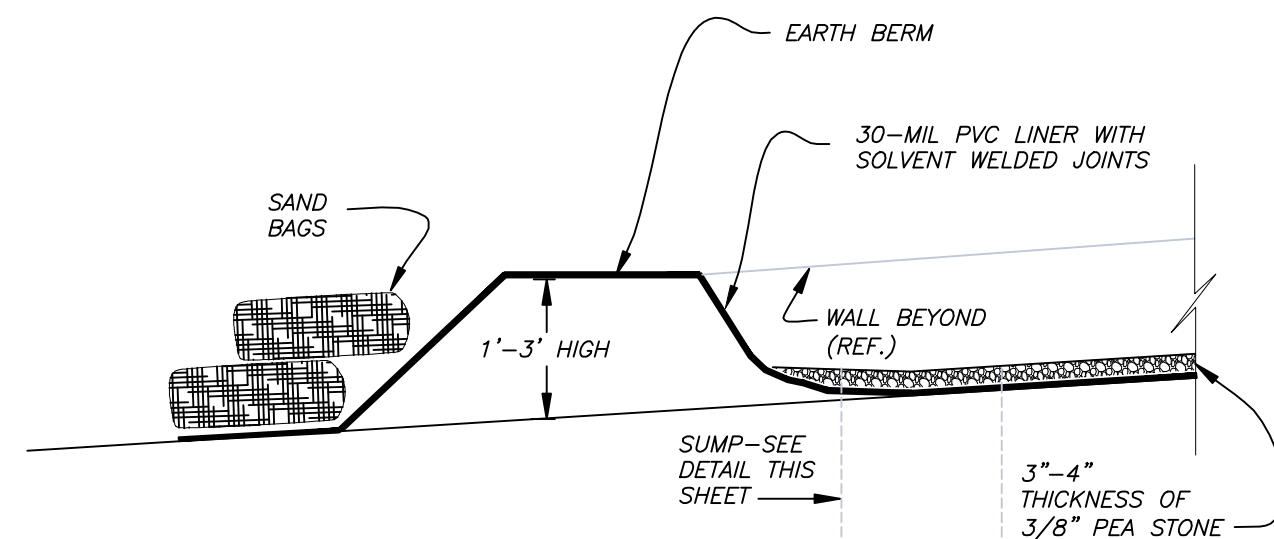

TYPICAL CONTAINMENT BERM DETAIL

NOT TO SCALE



FORMER TIDEWATER FACILITY			
PAWTUCKET, RHODE ISLAND			
TREATMENT SCHEMATIC & SYSTEM COMPONENTS DETAILS			
PREPARED BY:	GZA GeoEnvironmental, Inc. Engineers and Scientists 850 BROADWAY PROVIDENCE, RHODE ISLAND 02909 (401) 421-4140	PREPARED FOR:	NATIONAL GRID
PROJ MGR:	MSK	REVIEWED BY:	JPH
DESIGNED BY:	SMA	DRAWN BY:	CRB
DATE:	NOV. 2009	PROJECT NO.:	43654.00
		CHECKED BY:	SMA
		SCALE:	1"=50'
		REVISION NO.:	
			FIGURE 4
			SHEET NO.

UNLESS SPECIFICALLY STATED BY WRITTEN AGREEMENT, THIS DRAWING IS THE SOLE PROPERTY OF GZA GEOENVIRONMENTAL, INC. (GZA). THE INFORMATION SHOWN ON THE DRAWING IS SOLELY FOR USE BY GZA'S CLIENT OR THE CLIENT'S DESIGNATED REPRESENTATIVE FOR THE SPECIFIC PROJECT AND LOCATION IDENTIFIED ON THE DRAWING. THE DRAWING SHALL NOT BE TRANSFERRED, REUSED, COPIED, OR ALTERED IN ANY MANNER FOR USE AT ANY OTHER LOCATION OR FOR ANY OTHER PURPOSE WITHOUT THE PRIOR WRITTEN CONSENT OF GZA. ANY TRANSFER, REUSE, OR MODIFICATION TO THE DRAWING BY THE CLIENT OR OTHERS, WITHOUT THE PRIOR WRITTEN EXPRESS CONSENT OF GZA, WILL BE AT THE USER'S SOLE RISK AND WITHOUT ANY RISK OR LIABILITY TO GZA.

APPENDIX A
NOTICE OF INTENT



**RHODE ISLAND POLLUTANT DISCHARGE
ELIMINATION SYSTEM (RIPDES)
REMEDATION GENERAL PERMIT
NOTICE OF INTENT (NOI)**
(revised 7/08)

DEM USE ONLY	
Date Received	
Amount Received \$	
RIPDES# RIG	
Approval Date	
Data Entry Date	
Data Entry Initials	

I. OWNER			
Name: The Narragansett Electric Co., d/b/a National Grid			
Mailing Address: 40 Sylvan Road			
City: Waltham	State: MA	Zip: 02451	Phone: (781) 907-3651
Contact Person: Michele Leone		Title: Manager, NE Site Investigation & Remediation	
Email Address of Owner: michele.leone@us.ngrid.com			
II. OPERATOR (if different from owner)			
Name: GZA GeoEnvironmental, Inc.			
Mailing Address: 530 Broadway			
City: Providence	State: RI	Zip: 02909	Phone: (401) 421-4140
Contact Person: Stephen Andrus, P.E.		Title: Assistant Project Manager	
Email Address of Contact Person: stephen.andrus@gza.com			
III. SITE INFORMATION			
a. Please include the following items as part of the NOI: brief history of the site, the source of contamination; a description of the proposed remedial and/or dewatering activity creating the discharge; all available analytical data on impacted groundwater; a site plan showing location of monitoring and recovery wells, discharge point, and receiving waters; and an 8.5" x 11" photocopy of a USGS 1:24,000 topographic map depicting site location.			
Facility/Site Name: Former Tidewater Facility			
Facility/Site: Longitude: 71° 23' 00" Latitude: 41° 52' 06" SIC code(s): 4924, 1311			
Facility Address: 200 Taft Street			
City: Pawtucket	State: RI	Zip: 02860	
Type of Spill or Release: N/A		Approximate Duration of Project: 12 Months	
b. Has a prior NPDES permit been granted for the discharge? Yes ___ No <u>X</u> , if yes number: _____			
c. Has a prior NPDES application (Form 1 & 2C) ever been filed for the discharge? Yes ___ No <u>X</u> , if yes provide date of application and application number if available.			
d. Is the site/facility covered by any other DEM permit including: 1. multi-sector storm water general permit, 2. phase I or II construction storm water general permit, 3. Individual RIPDES Permit, if so please list them below: _____			
e. Is the site/facility subject to any other DEM permitting or other action which is causing the generation of the discharge? Yes ___ or No <u>X</u>			
If "Yes" please list the applicable permit numbers and DEM contacts here: <u>Joseph Martella</u> Case No. 95-022			

IV. DISCHARGE INFORMATION

a. Describe the discharge activities for which the owner/applicant is seeking coverage:

Empty stormwater which has accumulated in gas holders prior to demolition.

b. Provide the following information for each discharge:

Number of Discharge Points: 1

Maximum Flow Rate (cubic feet per second): 0.223 Is the maximum flow a design value? Y X N

Average Flow Rate (cubic feet per second): 0.178

c. Latitude and Longitude of the center of each outfall: pt. 1: long. 71° 22' 59" lat. 41° 52' 06"; pt. 2 long. _____ lat. _____, pt. 3 long. _____ lat. _____, pt. 4 long. _____ lat. _____, pt. 5 long. _____ lat. _____, pt. 6 long. _____ lat. _____.

d. If hydrostatic testing, total volume of the discharge (gallons):

e. Is the discharge intermittent X or seasonal _____?

f. Expected dates of discharge (mm/dd/yy): Start: 01 / 01 / 2010 End: 12 / 31 / 2010

g. Based on the analysis of sample(s) of the untreated influent, the applicant must check the box of the sub-categories that the potential discharge falls within:

- A) Gasoline Only, B) Fuel Oils (and Other Oils) Sites, C) Petroleum Sites Containing Other Pollutants
 D) VOC Only Sites, E) VOC Sites Containing Other Contaminants F) Sites Containing Primarily Metals
 G) Contaminated Construction Dewatering,
 H) Aquifer Pump Testing, Well Development, or Rehabilitation of Contaminated Wells
 I) Hydrostatic Testing of Pipelines and Tanks J) Contaminated Sump Discharge

V. TREATMENT SYSTEM INFORMATION

a. **Attach a complete description of the treatment system including:** a flow schematic depicting all major control points (i.e., alarms, sensors, valves) and treatment units; design calculations on the expected treatment performance (i.e., removal efficiency, carbon consumption calculations) including unit height and surface area; and manufacturers' specifications on major components of the treatment system. Also provide a basis for all design calculations and properly reference all design assumptions in order for calculations to be replicated. Include a discussion on the need for iron treatment to address iron scaling and/or iron bacteria build-up. Plans and specifications on all treatment systems must be signed and certified by a professional engineer registered in the State of Rhode Island.

b. Identify each applicable treatment unit (check all that apply):

- Oil/Water Separator, Granular Activated Carbon, Air Stripping, U/V Oxidation, Iron Treatment,
 Filtration, Ion Exchange, Bag Filter, Equalization Tanks, Air Stripper, Chlorination, Dechlorination,
 Other (please specify): _____

If system consists of GAC or Ion Exchange, provide time to carbon or resin exhaustion (days): Carbon 30-35 days

If system consists of air stripping, provide air/water ratio: _____ Resin 68 Days

c. Treatment System Design Flow (gpm): 100

d. Treatment System Maximum System Capacity (gpm): 100

e. Average Flow Rate of Treatment System (gpm): 80

f. Provide a description of chemical additives being used or planned to be used (attach MSDS sheets for each):

None

VI. RECEIVING WATER INFORMATION

a. Identify the discharge pathway: Direct, Indirect, Storm Drain, River/brook, Wetlands,

Other (describe): _____

b. Provide a narrative description of the discharge pathway, including the names of the receiving waters:

Treated water will be discharges to the Seekonk River through a temporary 6-inch line installed above grade.

c. Attach a detailed map(s) indicating the site location and location of the outfall to the receiving water:

1. For multiple discharges, number the discharges sequentially.

2. For indirect discharges, indicated the location of the discharge to the indirect conveyance and the discharge to surface waters. The map should include the location and distance to the nearest sanitary sewer.

d. Provide the Water Quality Classification of the receiving water: SB1 {a}.

e. If the proposed discharge is to freshwaters, provide the reported or calculated seven day-ten year low flow (7Q10) of the receiving water for the point of discharge in cubic feet per second (cfs):

_____. Attach any calculation sheets used to support stream flow and dilution calculations.

f. Is the receiving water a listed 303(d) water quality impaired or limited water? Yes No, If yes for which pollutant(s)? Water body ID RI0007019E-01

excess algea growth/Chlorophyll, low dissolved oxygen, nutrients and pathogens.

g. Is there a TMDL? Yes No If Yes, for which pollutants?

Nitrogen, Dissolved oxygen, Fecal Coliform

VII. INFLUENT CHARACTERIZATION (attach raw analytical data, include sample date and location)							
Pollutant	Believed Absent (Y/N)	Believed Present (Y/N)	Sample Type And Number	Test Method Minimum Level	Average (ug/l)	Max. (ug/l)	Design (ug/l)
Total Suspended Solids	N	Y	Grab/6	200 ug/l	1167	2000	2000
Total Residual Chlorine	Y	N					
Total Petroleum Hydrocarbons	N	Y	Grab/6	200 ug/l	560	840	840
Cyanide	N	Y	Grab/6	10 ug/l	41	60	60
Benzene	N	Y	Grab/6	1 ug/l	3.90	9.5	9.5
Toluene	N	Y	Grab/6	1 ug/l	41	86	86
Ethylbenzene	N	Y	Grab/6	1 ug/l	12.6	27	27
Total Xylenes (m,p,o)	N	Y	Grab/6	2 ug/l	112.1	229	229
Total BTEX	N	Y	Grab/6	1 ug/l	170	349	349
Ethylene dibromide	Y	N					
Methyl-t-Butyl Ether (MTBE)	Y	N	Grab/6	1 ug/l	<1	<1	<1
Tert-Amyl Methyl Ether	Y	N					
Carbon Tetrachloride	Y	N	Grab/6	1 ug/l	<1	<1	<1
1,4 Dichlorobenzene	Y	N	Grab/6	1 ug/l	<1	<1	<1
1,2 Dichlorobenzene	Y	N	Grab/6	1 ug/l	<1	<1	<1
1,3 Dichlorobenzene	Y	N	Grab/6	1 ug/l	<1	<1	<1
Total Dichlorobenzene	Y	N	Grab/6	1 ug/l	<1	<1	<1
1,1 Dichloroethane	Y	N	Grab/6	1 ug/l	<1	<1	<1
1,2 Dichloroethane	Y	N	Grab/6	1 ug/l	<1	<1	<1
1,1 Dichloroethylene	Y	N	Grab/6	1 ug/l	<1	<1	<1
cis - 1,2 Dichloroethylene	Y	N	Grab/6	1 ug/l	<1	<1	<1
Dichloromethane	Y	N	Grab/6	1 ug/l	<2	<2	<2
Tetrachloroethylene	Y	N					
1,1,1 Trichloroethane	Y	N	Grab/6	1 ug/l	<1	<1	<1
1,1,2 Trichloroethane	Y	N	Grab/6	1 ug/l	<1	<1	<1
Trichloroethylene	Y	N	Grab/6	1 ug/l	<1	<1	<1
Vinyl Chloride	Y	N	Grab/6	1 ug/l	<1	<1	<1
Acetone	Y	N	Grab/6	25 ug/l	<25	<25	<25
1,4 Dioxane	Y	N					
Total Phenols	Y	N					
Pentachlorophenol	Y	N					
Total Phthalates	Y	N					
Bis (2-Ethylhexyl) Phthalate	Y	N					
Total Group I PAHs	Y	N	Grab/6	2 ug/l	<2	<2	<2

VII. INFLUENT CHARACTERIZATION (attach raw analytical data, include sample date and location)							
Pollutant	Believed Absent (Y/N)	Believed Present (Y/N)	Sample Type And Number	Test Method Minimum Level	Average (ug/l)	Max. (ug/l)	Design (ug/l)
Benzo (a) Anthracene	Y	N	Grab/6	2 ug/l	<2	<2	<2
Benzo (a) Pyrene	Y	N	Grab/6	2 ug/l	<2	<2	<2
Benzo (b) Fluoranthene	Y	N	Grab/6	2 ug/l	<2	<2	<2
Benzo (k) Fluoranthene	Y	N	Grab/6	2 ug/l	<2	<2	<2
Chrysene	Y	N	Grab/6	2 ug/l	<2	<2	<2
Dibenzo (a,h) anthracene	Y	N	Grab/6	2 ug/l	<2	<2	<2
Indeno (1,2,3-cd) Pyrene	Y	N	Grab/6	2 ug/l	<2	<2	<2
Total Group II PAHs	N	Y	Grab/6	2 ug/l	22	48	48
Acenaphthene	Y	N	Grab/6	2 ug/l	<2	<2	<2
Acenaphthylene	Y	N	Grab/6	2 ug/l	<2	<2	<2
Anthracene	Y	Y	Grab/6	2 ug/l	<2	<2	<2
Benzo (ghi) Perylene	Y	N	Grab/6	2 ug/l	<2	<2	<2
Fluoranthene	Y	N	Grab/6	2 ug/l	<2	<2	<2
Fluorene	Y	N	Grab/6	2 ug/l	<2	<2	<2
Napthalene	N	Y	Grab/6	2 ug/l	22	48	48
Phenanthrene	Y	N	Grab/6	2 ug/l	<2	<2	<2
Pyrene	Y	N	Grab/6	2 ug/l	<2	<2	<2
Total Polychlorinated Bipheyls	Y	N	Grab/6				
Antimony	Y	N	Grab/6	25 ug/l	<25	<25	<25
Arsenic	Y	N	Grab/6	25 ug/l	<10	<10	<10
Cadmium	Y	N	Grab/6	5 ug/l	<5	<5	<5
Chromium III (trivalent, total recoverable)	Y	N	Grab/6	5 ug/l	<5	<5	<5
Chromium VI (hexavalent, total recoverable)	Y	Y	Grab/6	5 ug/l	<5	<5	<5
Copper	N	Y	Grab/6	5 ug/l	16	16	16
Lead (total recoverable)	N	Y	Grab/6	10 ug/l	26.5	29	29
Mercury	Y	N	Grab/6	0.4 ug/l	<0.4	<0.4	<0.4
Nickel (total recoverable)	Y	N	Grab/6	10 ug/l	<10	<10	<10
Selenium	Y	N	Grab/6	25 ug/l	<25	<25	<25
Silver	Y	N	Grab/6	5 ug/l	<5	<5	<5
Zinc (total recoverable)	N	Y	Grab/6	10 ug/l	21.7	28	28
Iron (total recoverable)	N	Y	Grab/6	25 ug/l	1007	1800	1800
Other (describe): See attached Sheet							

VIII. OWNER/OPERATOR CERTIFICATION

I certify under penalty of law that I have read and understood all terms and conditions of the above-referenced General Permit. I also certify under penalty of law that this document and all attachments were prepared under the direction or supervision in accordance with a system design to assure that qualified personnel properly gather and evaluate the information submitted. Based on my inquiry of the person or persons who manage the system, or those persons directly responsible for gathering the information, the information submitted is, to the best of my knowledge and belief, true, accurate, and complete. I am aware that there are significant penalties for submitting false information, including the possibility of a fine and imprisonment for knowing violations.

Print Owner's Name: MICHELE V. LEDNE

Print Owner's Title: MANAGER, NESIR

Signature: [Handwritten Signature]

Date: 11/12/09

Print Operator's Name: Stephen M Andrus, P.E.

Print Operator's Title: Assistant Project Manager

Signature: [Handwritten Signature]

Date: 11/13/09

APPENDIX B

TREATMENT SYSTEM COMPONENTS

REV.NO.	DESCRIPTION	PREVIOUS DWG	BY	DATE

ITEM	QTY.	REF.	DESCRIPTION

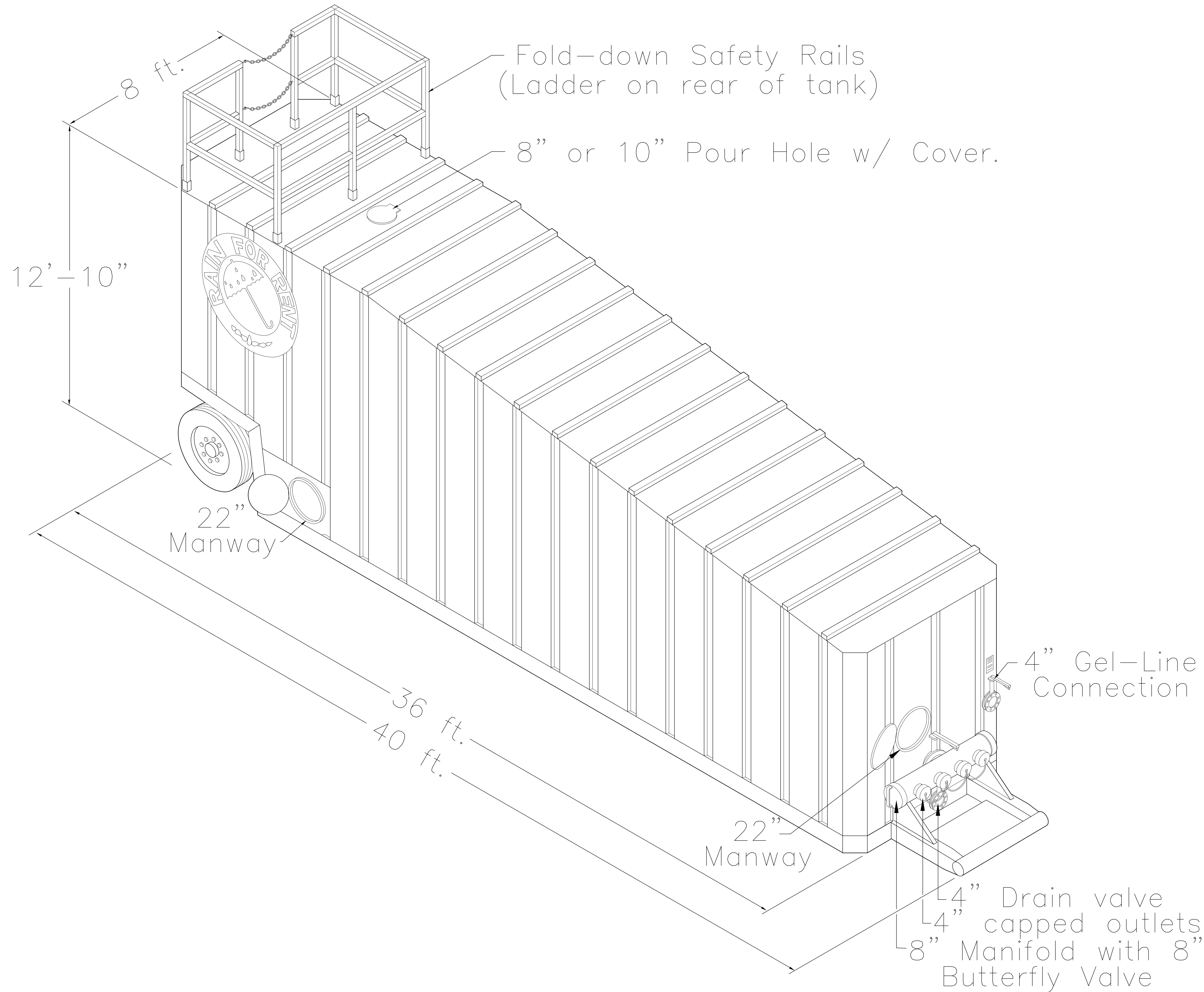

DATE:	3-25-03
SCALE:	NTC
DESIGNED:	
CHECKED:	
DRAWN:	S.HERNANDEZ

MANIFOLD TANK

21,000 GALLON STEEL MANIFOLD TANK
DETAIL

Rain For Rent Engineering
3404 STATE ROAD PO BOX 2248 BAKERSFIELD CA 93303

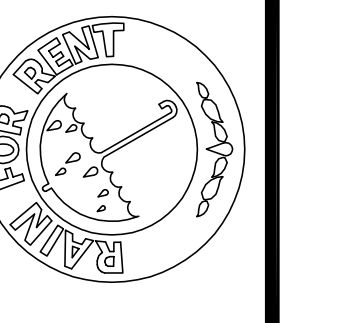

ALL INFORMATION CONTAINED IN OR ON THIS DRAWING IS THE PROPERTY OF RAIN FOR RENT. ALL RIGHTS ARE RESERVED. REPRODUCTION AND REPRODUCTION OF THIS DOCUMENT WITHOUT THE WRITTEN CONSENT OF RAIN FOR RENT IS PROHIBITED.

1	SHEET	1
DRAWING NUMBER		
103420		
JOB NUMBER		
1030004		

REVISIONS				
ZONE	REV	DESCRIPTION	DATE	APPROVED

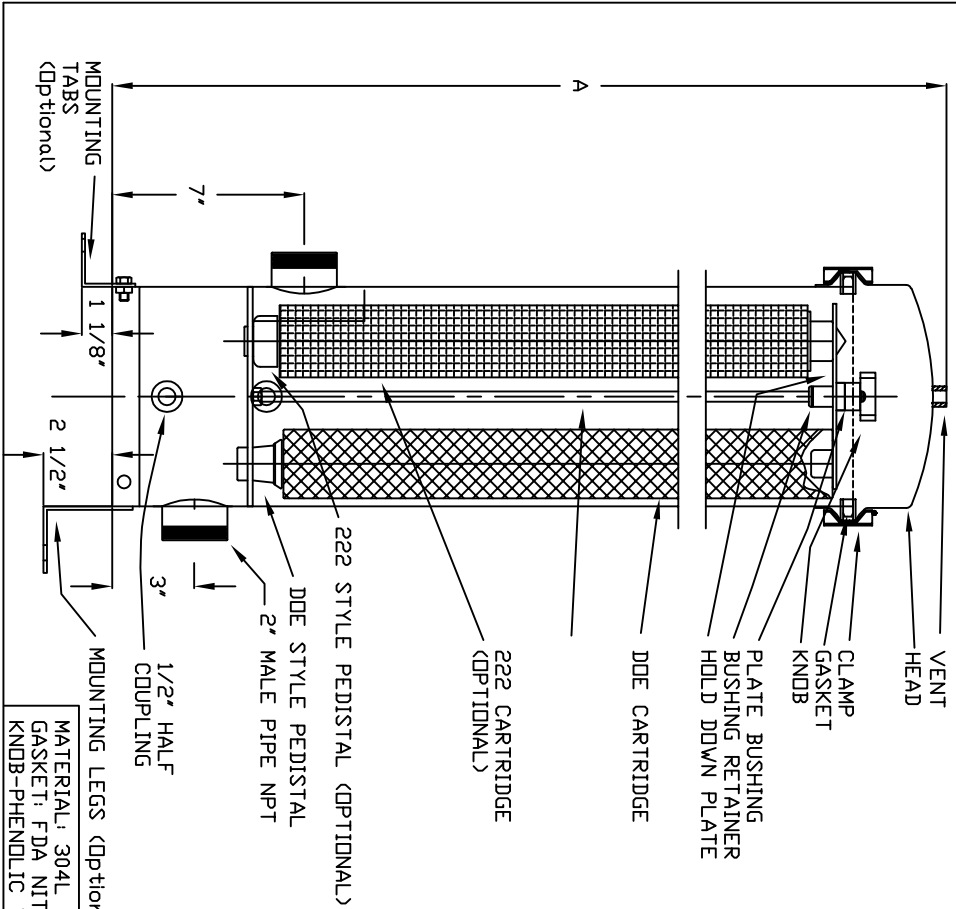
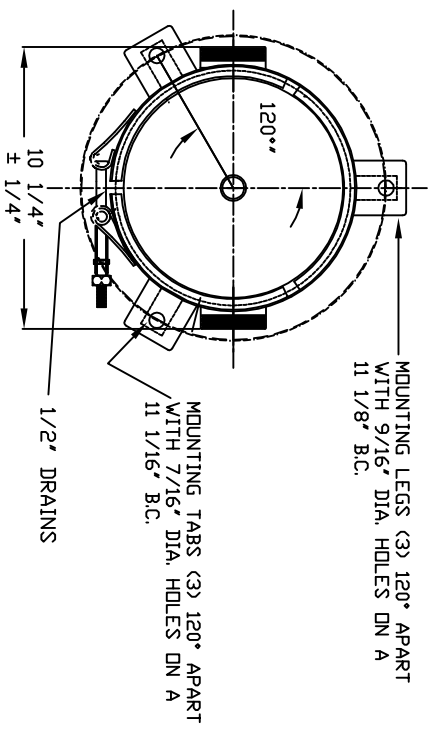

MATERIAL: 304L OR 316L
 GASKET: FDA NITRILE
 KNOB-PHENOLIC W/BRASS INSERT

SHELCO FILTERS
 100 BRADLEY STREET
 MIDDLETOWN, CT 06457

Tolerance unless otherwise specified
 x.xxx ± 0.005
 x.xx ± 0.010
 x.x ± 0.050
 x° ± 1°
 Fractional Dimensions ± 1/8"

A - DIMENSION			
CLAMP STYLE	SWING	BOLT STYLE	
1 HIGH	20	3/8"	20 7/8"
2 HIGH	30	3/8"	30 7/8"
3 HIGH	40	3/8"	40 7/8"
4 HIGH	50	3/8"	50 7/8"

SHELCO FILTERS
 4FDS & 5FDS SERIES HOUSING

DATE	DWG NO.	REV
5/29/03	4 & 5 FDS-NEW	

SCALE	DRAWN BY	SHEET
~	LJR	1 OF 1

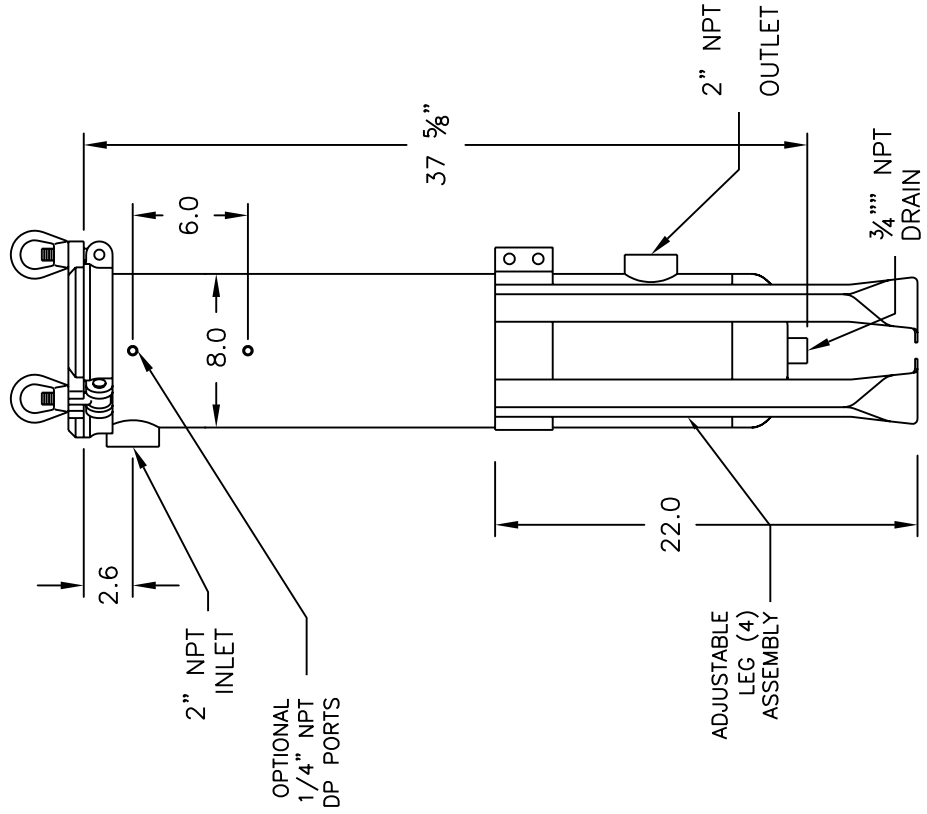
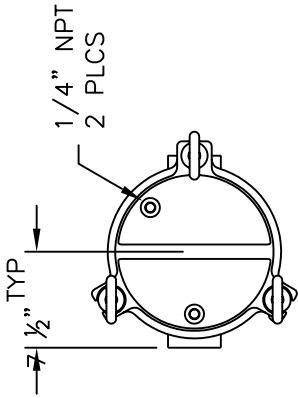

NOTES:

1. DESIGN PRESSURE - 150 PSI
2. DESIGN TEMPERATURE - 250°F
3. OPTIONS
 - A. MATERIALS OF CONSTRUCTION
 - CARBON STEEL
 - 304 STAINLESS
 - 316 STAINLESS
 - B. COVER GASKET MATERIAL
 - BUNA N
 - EPR
 - VITON
 - TEFLON
 - C. ADJUSTABLE TRIPOD LEGS
 - CARBON STEEL
 - 304 STAINLESS STEEL
 - NO LEGS
 - D. BASKET TYPE: (STAINLESS STEEL)
 - FILTER BAG - 9/64 DIA. PERFORATIONS
 - MESH LINED - 20, 30, 40, 50, 60, 70, 100, 150 or 200 MESH
 - PERFORATED STRAINER - 3/32, 1/8, 3/16, 1/4 PERFORATIONS
 - E. DIFFERENTIAL PRESSURE PORTS
 - 1/4" NPT - 2 PLACES
 - NO PORTS
4. SIZE #2 FILTER BAGS ARE ORDERED SEPARATELY
5. APPROXIMATE WEIGHTS
 - 802 HOUSING WEIGHT - 60 LBS.
 - ADJUSTABLE LEGS - 10 LBS.

MICRON TECHNOLOGIES
MICHIGAN CITY, INDIANA, USA

TITLE MODEL 80 EYE BOLT HOUSING
2" NPT

SIZE #2 - STYLE #2A

DR DME DATE 3/08/06 SCALE 1:10 SHEET 1 OF 1

FILENAME 1450 DWG NO. I-802EBS2A2P

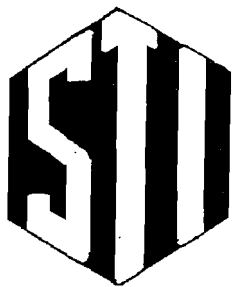

SERVICE TECH, INC.

Activated Carbon Engineering Sales and Service.

High Pressure Liquid Phase Activated Carbon Adsorbers (75 PSI "HP" Series)

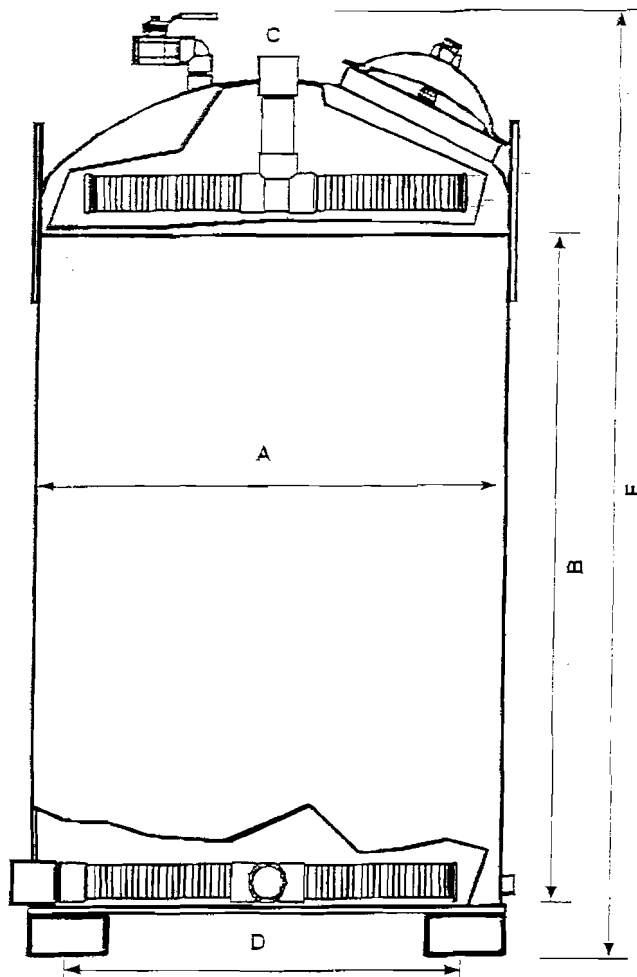

Model	Pounds GAC	Maximum Flow Rate	Diameter	Shell ht.	Inlet/Outlet	Overall Ht.	Forklift Width
HP500	500	35	36"	36"	2"	54"	30"
HP1000	1000	50	42"	48"	2"	67"	37"
HP2000	2000	100	48"	72"	4"	90"	42"
HP3000	3000	150	60"	72"	4"	96"	54"



SERVICE TECH, INC.

Activated Carbon Engineering, Sales and Service

**HP Series
Filter Vessels**

*IX Resin/Activated Carbon/Multi Media
(75 PSI)*

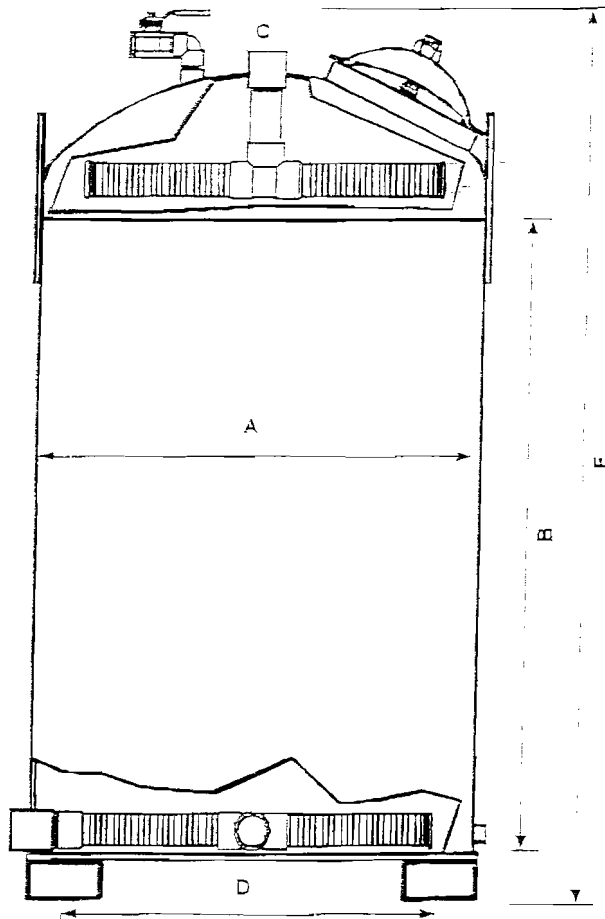

Model	Max Filter Media (cu. ft.)	Maximum Flow Rate	Diameter "A"	Shell ht. "B"	Inlet/ Outlet "C"	Overall Ht. "E"	Forklift Width "D"
HP3636	21	35	36"	36"	2"	54"	30"
HP3660	35	60	36"	60"	2"	72"	30"
HP4848	50	60	48"	48"	2"	60"	42"
HP4872	75	100	48"	72"	4"	90"	42"

Signet 8150 Battery Powered Flow Totalizer

Member of the ProcessPro® Family of Instruments



Panel Mount



Pipe, Wall, and Tank Mount



Integral Mount

Description

The Signet 8150 Battery Operated Flow Totalizer is compatible with the Signet 515 and 525 flow sensors, and will provide years of dependable operation. The large digital display indicates flow rate and totalized flow volume simultaneously. One of the three totalizers is resettable from the front panel or a remote location, while the second resettable totalizer can only be reset by entering a user-selectable security code. The third is a permanent non-resettable totalizer.

Our intuitive software design and four-button keypad provide for simple operation while setting screen displays

and programming the system. Calibration can be easily performed by entering the Auto-Cal feature and entering a value to match an external reference. Screen displays can be modified to suit the user's needs; along with the flow rate, any of the three totalizers can be selected as the displayed totalizer. Customers can quickly scroll through the totalizers simply by pressing any key on the keypad. A display averaging feature is included for applications where the flow in the pipe fluctuates. For applications where flow stops and starts due to production needs, a no-flow indicator will display the hours of non-flow.





Features

- Three totalizers: 2 resettable and 1 permanent, user selectable
- Long-lasting lithium batteries
- Mounting versatility
- No-flow indicator
- Large digital display with averaging
- Simple push-button operation
- User selectable access code prevents unwanted changes
- Auto-calibration

Applications

- Wastewater Flow Accumulation
- Water Treatment Systems
- Remote or Mobile Treatment/Distribution Systems
- Irrigation Systems
- Filtration Systems
- Commercial Pools & Spas
- Groundwater Remediation
- RO Concentrate
- Process Flow Monitoring
- UPW Distribution
- Demineralizer Regeneration
- Process Cooling Water

System Overview

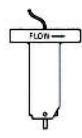
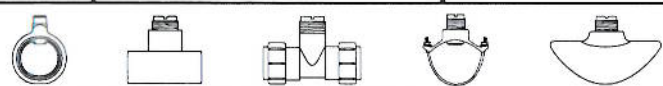
<p>Panel Mount Signet 8150 Flow Totalizer (includes mounting bracket and panel gasket)</p> 	<p>Pipe, Tank, Wall Mount Signet 8150 Flow Totalizer</p> 	<p>Integral Mount Signet 8150 Flow Totalizer (includes adapter and sensor)</p> 
<p>Signet Universal Adapter Kit (3-8050) (sold separately)</p> 	<p>Signet Flow Sensor (sold separately) 515 525</p> 	<p>Signet Flow Sensor (sold separately) 515 525</p> 
<p>Signet Fittings (sold separately)</p> 		



Dimensions

3-8150-1P

Panel Mount

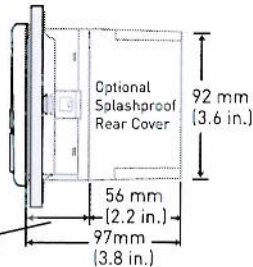
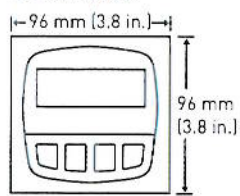

3-8150-1 with universal mount

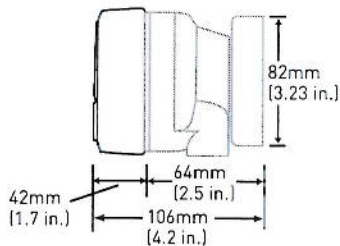

Model 515 Integral Mount Sensors - see 515 data sheet for specifications

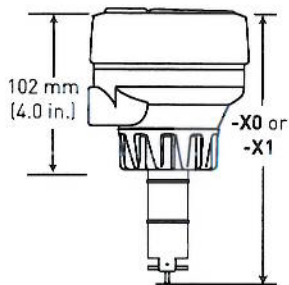

-X0 = 152mm (6.0 in.)
-X1 = 185mm (7.3 in.)

Model 8150

Ordering Notes

- 1) For panel version, cutout must be 92 x 92 mm (3.62 x 3.62 in.)
- 2) To mount the panel version on a wall, use the heavy duty wall mount bracket.
- 3) Use the Universal mounting kit with the Field mount instrument to mount to a pipe, tank or wall.
- 4) An optional splash proof rear cover can be ordered separately if needed.

Please refer to **Wiring, Installation, and Accessories sections for more information.**

Rev A (3/09)

© Georg Fischer Signet LLC

3401 Aerojet Avenue, El Monte, CA 91731-2882 U.S.A. • Tel. (626) 571-2770 • Fax (626) 573-2057 • www.gfsignet.com • e-mail: signet.ps@georgfischer.com
Specifications subject to change without notice. All rights reserved. All corporate names and trademarks stated herein are the property of their respective companies.

Specifications

General

Compatibility:

Signet 515 and 525 flow sensors

Input Freq. Range: 0 to 400Hz

Accuracy: ±0.5% of reading

Display: LCD type

- 4-digit upper line - flow rate
- 8-digit lower line - volume totalizer count, either resettable or permanent

Averaging: 0 to 120 secs.

Contrast: Automatic

Low Battery Indication:

Battery symbol appears on LCD display

8-digit resettable totalizers:

Stored until user resets; continues to be stored even after batteries are removed

8-digit permanent:

Kept permanently, even when batteries are removed

Materials

- Enclosure: PBT resin
- Keypad Material: Sealed 4-key silicon rubber
- Panel Case Gasket: Neoprene
- Window: Polyurethane coated polycarbonate

Electrical

Battery:

Two 3.6V Lithium thionyl chloride, A-size

Battery life:

4 years nominal @ 50 °C (122 °F)

Environmental

Operating Temperature:

-10 °C to 65 °C (14 °F to 149 °F)

Storage Temperature:

-40 °C to 100 °C (-40 °F to 212 °F)

Relative Humidity

0 to 95% Non-condensing

Enclosure: NEMA 4X/IP65 front

Shipping Weight

0.5 kg

1.1 lb

Standards and Approvals

- CE
- CUL, UL
- RoHS compliant
- Manufactured under ISO 9001 for Quality and ISO 14001 for Environmental Management

Ordering Information

Instrument Part Number	
3-8150	Battery Operated Flow Totalizer
	Field, Panel, or Integral Sensor mount - Choose One
-1	Field mount for pipe, tank, and wall mounting
-1P	Panel mount; includes mounting bracket and panel gasket
-P0*	3-8150-1 integrally mounted on Model 515 Paddlewheel (Part No. 3-8510-P0) for ½ to 4 in. pipes, with a polypropylene body, Black PVDF rotor, and Titanium pin
-P1*	3-8150-1 integrally mounted on Model 515 Paddlewheel (Part No. 3-8510-P1) for 5 to 8 in. pipes, with a polypropylene body, Black PVDF rotor, and Titanium pin
-T0*	3-8150-1 integrally mounted on Model 515 Paddlewheel (Part No. 3-8510-T0) for ½ to 4 in. pipes, with a natural PVDF body, rotor, and pin
-V0*	3-8150-1 integrally mounted on Model 515 Paddlewheel (Part No. 3-8510-V0) for ½ to 4 in. pipes, with a natural PVDF body, rotor, and Hastelloy pin
3-8150	-1 Example Part Number

* See individual sensor sheets for more sensor information.

Mfr. Part No.	Code	Mfr. Part No.	Code
3-8150-1	159 000 929	3-8150-P1	159 000 932
3-8150-1P	159 000 930	3-8150-T0	159 001 011
3-8150-P0	159 000 931	3-8150-V0	159 001 012

Accessories and Replacement Parts

Mfr. Part No.	Code	Description
Mounting		
3-8050	159 000 184	Universal mounting kit
3-0000.596	159 000 641	Heavy duty wall mount bracket (panel mount only)
3-5000.598	198 840 225	Surface mount bracket (panel mount only)
3-8050.395	159 000 186	Splashproof rear cover (panel mount only)
Liquid Tight Connectors		
3-9000.392	159 000 368	Liquid tight connector kit (includes 3 connectors)
3-9000.392-1	159 000 839	Liquid tight connector, NPT (1 connector)
3-9000.392-2	159 000 841	Liquid tight connector, PG 13.5 (1 connector)
Other		
7400-0011	159 000 935	Lithium battery, 3.6 V, size AA (2 required)
5523-0222	159 000 392	Cable (per foot), 2 cond. w/shield, 22 AWG
Replacement Parts for Integral Mount Units - see Model 515 catalog pages for information		
3-8051	159 000 187	Flow integral mounting kit, NPT (replacement)
3-8510-P0	198 864 504	Sensor for ½ to 4 in. pipes, Polypropylene body
3-8510-P1	198 864 505	Sensor for 5 to 8 in. pipes, Polypropylene body
3-8510-T0	159 000 622	Sensor for ½ to 4 in. pipes, all natural PVDF
3-8510-V0	198 864 506	Sensor for ½ to 4 in. pipes, PVDF body

CARBON ACTIVATED CORP.

Activated Carbon and Related Services

COC - L 60

Coconut Shell Carbon for Water Purification

COC-L60 Granular Activated Carbon (GAC) is manufactured from select grades of coconut shell and features a high density, large micropore volume and high surface area. It's commonly used for the purification of potable water, beverage manufacture, dialysis, aquarium water and a variety of food grade applications. In properly designed systems, **COC-L60** will effectively remove chlorine, chloramines, lead, radon, TCE, PCE, THM's, Phenols, pesticides, detergents, taste & odor, etc. **COC-L60** meets AWWA Standard B-600-74, ANSI/NSF Standard 61 and Food Chemicals Codex Standards for drinking water applications.

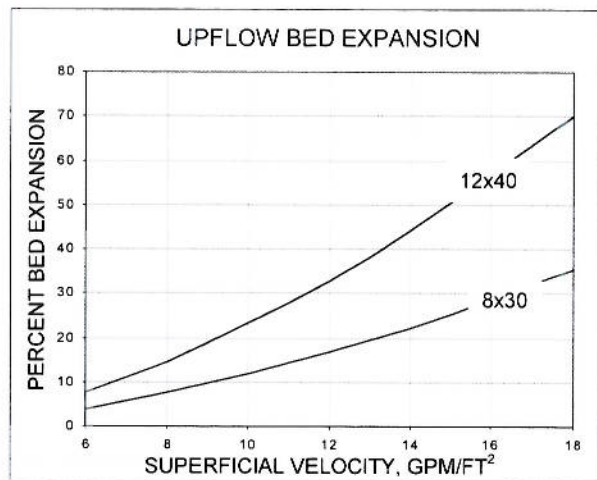
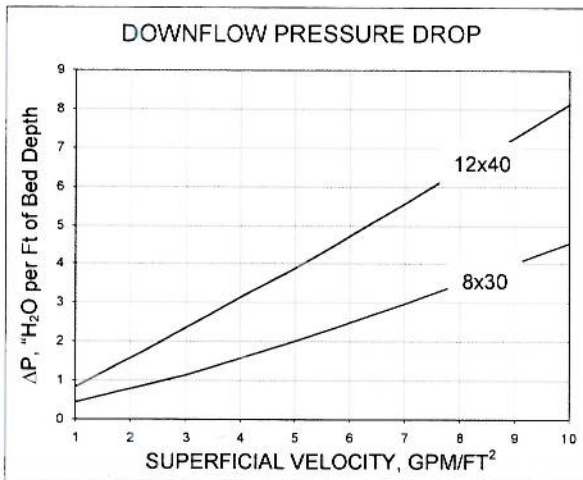

TYPICAL PHYSICAL PROPERTIES / SPECIFICATIONS

Iodine Number	1150 - 1200
Apparent Density (ASTM 2854), g/cc	0.48 - 0.50
	lb/ft ³
	29-31
Abrasion No., min.	85
Particle Size	8x30
	12x40
	20x50
Total Surface Area (BET), m ² /g	1150 - 1200
Ash (ASTM D-2866)	2 - 3%
Moisture, max as packed	2%



STANDARD PACKAGING:

55lb or 27.5lb POLYLINE D POLYPROPYLENE BAGS. 200lb FIBER DRUMS. 1100lb SUPERSACKS.

This information is offered solely for your consideration and verification. It has been gathered from reference materials and/or test procedures and is believed to be true and accurate. None of this information shall constitute a warranty or representation, expressed or implied for which we assume legal responsibility or that the information or goods is fit for any particular use either alone or in combination with other goods or processes.



CGS

CATION EXCHANGE RESIN
SOFTENING GRADE
Na FORM

RESINTECH CGS is a light colored, high capacity, gel type sulfonated polystyrene cation resin supplied in the sodium form as moist, tough uniform spherical beads. *ResinTech CGS* is intended for use in water softening applications, where free chlorine is not present. (It is also available as a dark colored product – *ResinTech CGS-BL* – with identical properties.)

FEATURES & BENEFITS

• **COMPLIES WITH FDA REGULATIONS FOR POTABLE WATER APPLICATIONS**

Conforms to paragraph 21CFR173.25 of the Food Additives Regulations of the F.D.A. *

• **EXCELLENT REGENERATION EFFICIENCY**

Virtually the same operating capacity as premium grade *ResinTech CG8-BL*

• **NSF/ANSI-61 CERTIFIED FOR MATERIAL SAFETY**



• **UNIFORM PARTICLE SIZE**

16 to plus 50 mesh range; gives a LOWER PRESSURE DROP while maintaining SUPERIOR KINETICS.

• **SUPERIOR PHYSICAL STABILITY**

90% plus sphericity and high crush strengths together with a very uniform particle size provide greater resistance to bead breakage while maintaining low pressure drops.

• **LOW COLOR THROW**

* For potable water applications, the resin must be properly pre-treated, usually by multiple exhaustion and regeneration cycles, to insure compliance with extractable levels

HYDRAULIC PROPERTIES

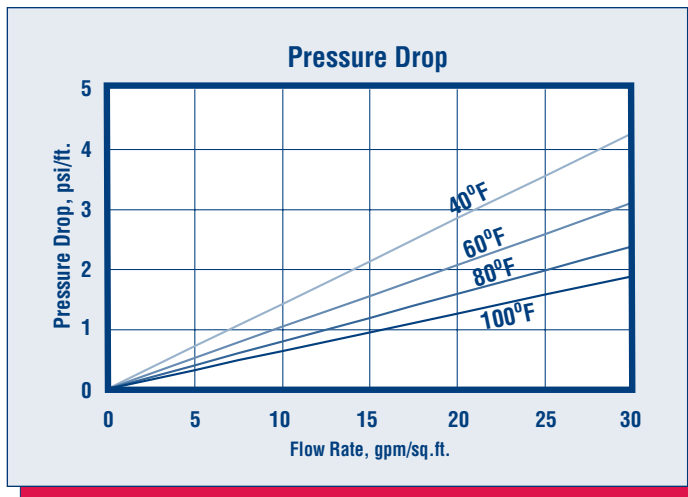

PRESSURE DROP -

The graph above shows the expected pressure loss per foot of bed depth as a function of flow rate, at various temperatures.

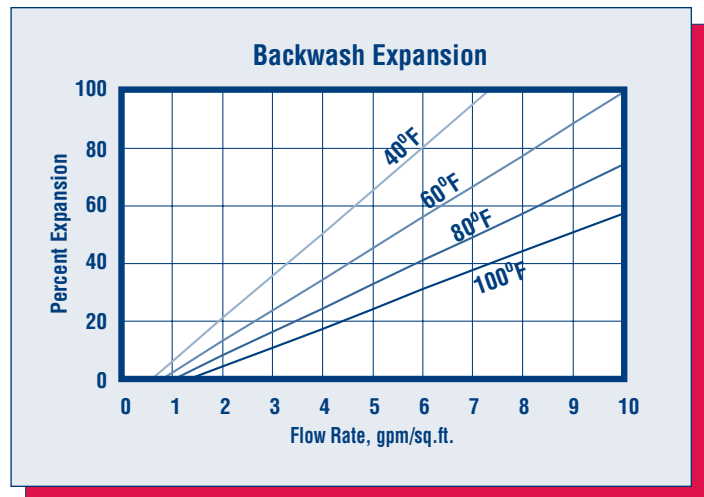

BACKWASH -

After each cycle the resin bed should be backwashed at a rate that expands the bed 50 to 75 percent. This will remove any foreign matter and reclassify the bed. The graph above shows the expansion characteristics of *ResinTech CGS* in the sodium form.

PHYSICAL PROPERTIES

Polymer Structure	Styrene Crosslinked with DVB
Functional Group	R-(SO ₃) ⁻ M ⁺
Ionic Form, as shipped	Sodium
Physical Form	Tough, Spherical Beads
Screen Size Distribution	16 to 50
+16 mesh (U.S. Std)	< 5 percent
-50 mesh (U.S. Std)	< 1 percent
pH Range	0 to 14
Sphericity	90+ percent
Uniformity Coefficient	Approx. 1.6
Water Retention	
Sodium Form	48 to 54 percent
Solubility	Insoluble
Shipping Weight	
Sodium Form	50 lbs./cu.ft.
Total Capacity	
Sodium Form	1.90 meq/ml min.

SUGGESTED OPERATING CONDITIONS

Maximum Temperature	
Sodium Form	250° F
Minimum Bed Depth	24 inches
Backwash Rate	50 to 75% Bed Expansion
Regenerant (NaCl or KCl)	
Concentration	10 to 15 percent
Flow Rate	0.5 to 1.5 gpm/cu.ft.
Contact Time	> 20 minutes
Level	4 to 15 pounds/cu.ft.
Displacement Rate	Same as Regen Flow Rate
Volume	10 to 15 gallons/cu.ft.
Fast Rinse Rate	Same as Service Flow Rate
Volume	35 to 60 gallons/cu.ft.
Service Flow Rate	2 to 10 gpm/cu.ft.

OPERATING CAPACITY

Sodium Chloride (NaCl) Regeneration -

The sodium cycle operating capacity of *ResinTech CGS* for hardness removal at various regeneration levels with an influent calcium/magnesium ratio of 2/1 and a hardness level of 500 ppm, as CaCO₃, is shown in the following table:

Pounds NaOH/cu.ft.	Capacity Kilograins/cu.ft.
5	20.0
7.5	25.4
10	29.0
15	33.0

Potassium Chloride (KCl) Regeneration -

The potassium cycle operating capacity of *ResinTech CGS* for hardness removal at various regeneration levels with an influent calcium/magnesium ratio of 2/1 and a hardness level of 500 ppm, as CaCO₃, is shown in the following table:

Pounds NaOH/cu.ft.	Capacity Kilograins/cu.ft.
5	16.6
7.5	21.8
10	26.6
15	31.2

APPLICATIONS

Softening -

ResinTech CGS is ideally suited for industrial, commercial, or residential softening applications where free chlorine is not present because of its high capacity, uniform particle size and good physical stability.

***CAUTION: DO NOT MIX ION EXCHANGE RESIN WITH STRONG OXIDIZING AGENTS.** Nitric acid and other strong oxidizing agents can cause explosive reactions when mixed with organic materials, such as ion exchange resins.

Material Safety Data Sheets (MSDS) are available for all ResinTech Inc. products. To obtain a copy, contact your local ResinTech sales representative or our corporate headquarters. They contain important health and safety information. That information may be needed to protect your employees and customers from any known health and safety hazards associated with our products. We recommend that you secure and study the pertinent MSDS for our products and any other products being used. These suggestions and data are based on information we believe to be reliable. They are offered in good faith. However we do not make any guarantee or warranty. We caution against using these products in an unsafe manner or in violation of any patents; further we assume no liability for the consequences of any such actions.

RESINTECH is a registered trademark ® of RESINTECH INC.

CGSver010603



SBG1

ANION EXCHANGE RESIN
TYPE ONE GEL
CI OR OH FORM

RESINTECH SBG1 is a high capacity, shock resistant, gelular, Type 1, strongly basic anion exchange resin supplied in the chloride or hydroxide form as moist, tough, uniform, spherical beads. *RESINTECH SBG1* is intended for use in all types of deionization systems and chemical processing applications. It is similar to *RESINTECH SBG1P* but has a higher volumetric capacity and exhibits lower TOC leach rates. This makes it the better performer in single use applications such as in cartridge deionization and when high levels of regeneration are used such as in polishing mixed beds. On the other hand, *RESINTECH SBG1P* is more resistant to organic fouling and gives higher operating capacities at low regeneration levels such as those used in make up demineralizers.

FEATURES & BENEFITS

- COMPLIES WITH FDA REGULATIONS FOR POTABLE WATER APPLICATIONS.**

Conforms to paragraph 21CFR173.25 of the Food Additives Regulations of the F.D.A.*

- HIGH TOTAL CAPACITY**

Provides longer run lengths in single use applications or where high levels of regeneration are used such as in mixed bed polishers, cartridge demineralizers.

- NSF/ANSI 61 CERTIFIED FOR MATERIAL SAFETY**

WQA Gold Seal Certified when ordered as SBG1-HP



- UNIFORM PARTICLE SIZE**

16 to plus 50 mesh range; gives a LOWER PRESSURE DROP while maintaining SUPERIOR KINETICS.

- SUPERIOR PHYSICAL STABILITY**

- LOWER TOC LEACH RATE**

Makes it ideal for polishing mixed beds in wafer washing and other high purity water polishing applications.

* For potable water applications, the resin must be properly pre-treated, usually by multiple exhaustion and regeneration cycles, to ensure compliance with extractable levels

HYDRAULIC PROPERTIES

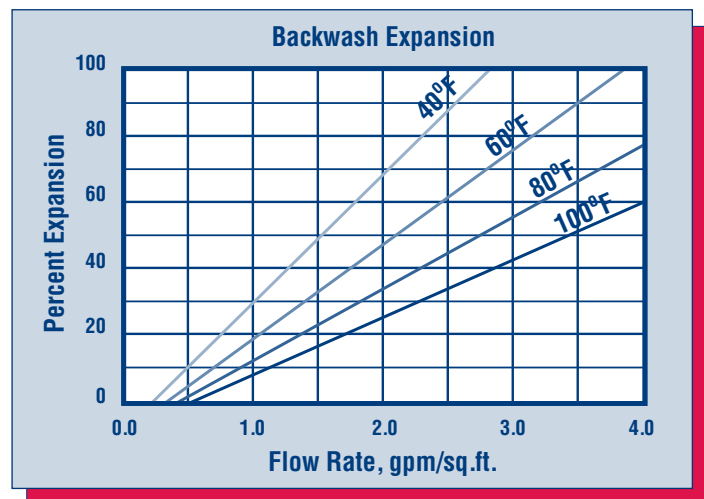
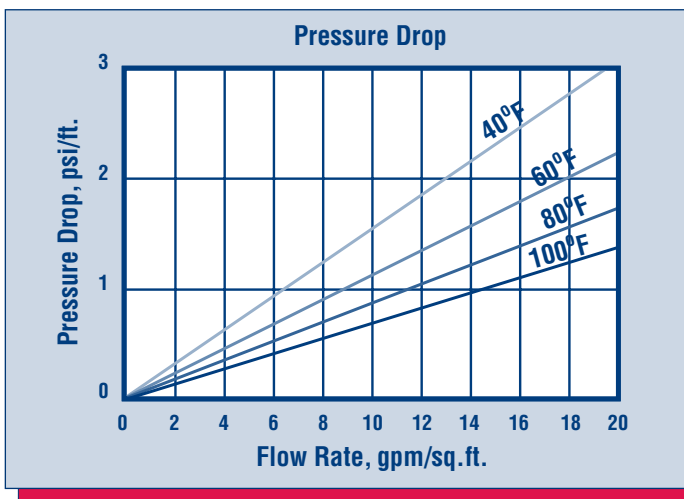

PRESSURE DROP

The graph above shows the expected pressure loss per foot of bed depth as a function of flow rate, at various temperatures.

BACKWASH

After each cycle the resin bed should be backwashed at a rate that expands the bed 50 to 75 percent. This will remove any foreign matter and reclassify the bed. The graph above shows the expansion characteristics of *RESINTECH SBG1* in the sodium form.

RESINTECH® SBG1

PHYSICAL PROPERTIES

Polymer Structure	Styrene Crosslinked with DVB
Functional Group	R-N-(CH ₃) ₃ ⁺ Cl ⁻
Ionic Form, as shipped	Chloride or Hydroxide
Physical Form	Tough, Spherical Beads
Screen Size Distribution	16 to 50
+16 mesh (U.S. Std)	< 5 percent
-50 mesh (U.S. Std)	< 1 percent
pH Range	0 to 14
Sphericity	> 93 percent
Uniformity Coefficient	Approx. 1.6
Water Retention	
Chloride Form	43 to 50 percent
Hydroxide Form	Approx. 53 to 60 percent
Solubility	Insoluble
Approximate Shipping Weight	
Cl Form	44 lbs/cu.ft.
OH Form	41 lbs/cu.ft.
Swelling Cl- to OH-	18 to 25 percent
Total Capacity	
Cl Form	1.45 meq/ml min
OH Form	1.15 meq/ml min

SUGGESTED OPERATING CONDITIONS

Maximum Continuous Temperature	
Hydroxide Form	140° F
alt Form	170° F
Minimum Bed Depth	24 inches
Backwash Rate	50 to 75 percent Bed Expansion
Regenerant Concentration*	2 to 6 percent
Regenerant Flow Rate	0.25 to 1.0 gpm/cu.ft.
Regenerant Contact Time	At least 40 Minutes
Regenerant Level	4 to 10 pounds/cu.ft.
Displacement Rinse Rate	Same as Regenerant Flow Rate
Displacement Rinse Volume	10 to 15 gals/cu.ft.
Fast Rinse Rate	Same as Service Flow Rate
Fast Rinse Volume	35 to 60 gals/cu.ft.
Service Flow Rates	
Polishing Mixed Beds	3 to 15 gpm/cu.ft.
Non-Polishing Apps.	2 to 4 gpm/cu.ft.

OPERATING CAPACITY

The operating capacity of *RESINTECH SBG1* for a variety of acids at various regeneration levels when treating an influent with a concentration 500 ppm, expressed as CaCO₃ is shown in the following table:

Pounds NaOH/ft ³	Capacity Kilograms per cubic foot			
	HCl	H ₂ SO ₄	H ₂ SiO ₃	H ₂ CO ₃
4	11.3	14.0	14.7	18.6
6	12.8	16.3	17.3	19.8
8	14.3	13.3	19.5	21.6
10	15.5	20.0	22.2	22.2

APPLICATIONS

DEMINEERALIZATION –

RESINTECH SBG1 is highly recommended for use in mixed bed demineralizers, wherever complete ion removal; superior physical and osmotic stability and low TOC leachables are required such as in wafer fabrication and other ultrapure applications.

RESINTECH SBG1 has high total capacity and low swelling on regeneration and provides maximum operating capacity in cartridge deionization applications. It is ideal for single use applications such as precious metal recovery, radwaste disposal and purification of toxic waste streams. Highly crosslinked Type 1, styrenic anion exchangers have greater thermal and oxidation resistance than other types of strong base resins. They can be operated and regenerated at higher temperatures. The combination of lower porosity, high total capacity and Type 1 functionality make *RESINTECH SBG1* the resin of choice when water temperatures exceed 85°F and where the combination of carbon dioxide, borate and silica exceed 40% of the total anions.

RESINTECH SBG1P and *RESINTECH SBG1* are quite similar; the difference between them is the degree of porosity. *RESINTECH SBG1P* has greater porosity that gives it faster kinetics, and greater ability to reversibly sorb slow moving ions such as Naturally occurring Organic Matter (NOM). At lower regeneration levels and where chlorides make up a substantial portion of the anion load, or where the removal and elution of naturally occurring organics is of concern *RESINTECH SBG1P*, SBACR or SBG2 should be considered. At the higher regeneration levels used in mixed bed polishers *RESINTECH SBG1* provides higher capacity, and the lowest possible TOC leach rates.

***CAUTION:DO NOT MIX ION EXCHANGE RESIN WITH STRONG OXIDIZING AGENTS.** Nitric acid and other strong oxidizing agents can cause explosive reactions when mixed with organic materials, such as ion exchange resins.

Material Safety Data Sheets (MSDS) are available for all ResinTech Inc. products. To obtain a copy, contact your local ResinTech sales representative or our corporate headquarters.

They contain important health and safety information. That information may be needed to protect your employees and customers from any known health and safety hazards associated with our products. We recommend that you secure and study the pertinent MSDS for our products and any other products being used. These suggestions and data are based on information we believe to be reliable. They are offered in good faith. However we do not make any guarantee or warranty. We caution against using these products in an unsafe manner or in violation of any patents; further we assume no liability for the consequences of any such actions.

RESINTECH is a registered trademark ® of RESINTECH INC.

APPENDIX C

BREAKTHROUGH CALCULATIONS



SERVICE TECH, INC.

Activated Carbon Engineering, Sales and Service

October 30, 2009

Mr. Steve Andrus

GZA

530 Broadway

Providence, RI 02909

Ph 401.421.4140

RE: Filter media Usage
Pawtucket, RI

Dear Mr. Andrus:

Per our recent correspondences, the following carbon usage calculations are provided for the groundwater dewatering project.

GAC Usage(lbs./day) = Flow(GPD)*Concentration(PPB)^(1-1/n)*(0.0083/K)

- Flow is in total gallons per day
- Concentrations for individual compounds is in PPB
- 1/n and K are values given per compound

Constants for compound in question:

	K	1/n
Benzene	1200	0.4
Ethylbenzene	225	0.79
Naphthalene	7250	0.42
Toluene	1250	0.44
Xylenes	22000	0.19
Styrene		

Compounds detected were grouped with other compounds with similar adsorption capacities as follows:

Benzene: includes; isopropylbenzene, trimethylbenzenes

Toluene: includes isopropyltoluene

Xylenes : iall xylene compounds are grouped together

Carbon usage is estimated to be 0.34 pounds per 1000 gallons treated. The system will be sized to provide adequate contact time for the flow rate expected.

For the metals listed in the table below, cation exchange resin is the recommendation of our technical partner, ResinTech. The CGS is a strong acid cation exchange resin in the sodium (Na⁺-form) or more commonly referred to as softening resin. These resins have high selectivity for divalent metal cations, but will also remove background ions such as hardness (Ca⁺² and Mg⁺²). The total ion load for the resin will include the metals of concern, the hardness ions, along with the iron and manganese noted on the analysis. Any other soluble metal cations present that were not measured will also load the resin and decrease throughputs.

Ion exchange resin calculations are done with the concentrations represented in the “as CaCO₃” forms. The concentrations reported on the analysis will be assumed to be reported “as ion” unless otherwise noted. These ion concentrations will be converted to “as CaCO₃” equivalents for the purpose of capacity calculations. The assumed concentrations will also be the worst case noted on the analysis. Below is a table of concentrations and conversions.

Metal	Concentration	Conversion Mult.	Concentration as CaACO3
Copper	0.016 ppm	1.57	0.025 ppm
Lead	0.029 ppm	0.48	0.012 ppm
Zinc	0.031 ppm	1.54	0.048 ppm
Iron	1.8 ppm	1.79	3.19 ppm
Manganese	0.27 ppm	1.82	0.49 ppm
Calcium	0.45 ppm	2.5	1.13 ppm
Magnesium	0.15 ppm	4.12	0.62 ppm

Total Metal Concentration 5.52 ppm as CaCO₃

The capacity of a virgin cubic foot (Cuft) of the CGS is approximately 40,000/grains/Cuft. For purpose of capacity calculations we will use a capacity of 32,000 grains/Cuft. To build in a 20% safety factor. For reference, 7,000 grains represents 1 Lg of metals removal capacity. As noted, the total metals include the background concentrations of hardness iron and manganese, through not being regulated.

To calculate capacity, the concentration of the load needs to be converted from ppm as CaCO₃ to grains/gallon as CaCO₃. This is a simple calculation as 17.1 ppm as CaCO₃ is equal to 1 grain/gallon.

5.52 ppm as CaCO₃/ 17.1 ppm as CaCO₃ per grain/gallon = 0.323 grains/gallon

To calculate capacity, you divide the grains capacity of the resin by the load concentration in grains per gallon. The result is the gallons/Cuft of resin expected.

32,000 grains/Cuft/0.323 grains/gallon = Approx. 99,000 gallons/Cuft of resin

For cyanide, an anion resin is required and based upon the concentration and water chemistry, the throughput usage will be about the same; 100,000 gallon per cubic foot of resin.

The calculations above can be manipulated as needed if the ionic load changes for the resin. The resin should be applied with a volume flow range of 2-5 GPM/Cuft of resin. A minimum bed depth of 30" is also required for proper use.

This information is offered in good faith and is presented for what should be a reasonable expectation for performance. As noted many factors can impact performance and should be monitored in addition to the resin performance itself.

If you require additional information, please contact the undersigned at your earliest convenience.

Sincerely,
Service Tech, Inc.

Tim Rutherford
Project Manager

APPENDIX D
LABORATORY DATA SHEETS



GZA GeoEnvironmental, Inc.
106 South Street
Hopkinton, MA 01748
(781) 278-4700

Laboratory Identification Numbers:
MA and ME: **MA092** NH: **2028**
CT: **PH0579** RI: **LAO00236**
NELAC - NYS DOH: **11063**

ANALYTICAL REPORT

GZA GeoEnvironmental, Inc.
530 Broadway
Providence, RI 02909

Meg Kilpatrick

Project No.: **03.0043654.00**
Work Order No.: **0908-00130**
Date Received: **08/27/2009**
Date Reported: **09/10/2009**

SAMPLE INFORMATION

Date Sampled	Matrix	Laboratory ID	Sample ID
08/26/2009	Aqueous	0908-00130 001	GH-7 S-1
08/26/2009	Aqueous	0908-00130 002	GH-7 S-1 Dissolved Metals
08/26/2009	Aqueous	0908-00130 003	GH-7 S-2
08/26/2009	Aqueous	0908-00130 004	GH-7 S-2 Dissolved Metals
08/26/2009	Aqueous	0908-00130 005	GH-7 S-3
08/26/2009	Aqueous	0908-00130 006	GH-7 S-3 Dissolved Metals
08/26/2009	Aqueous	0908-00130 007	GH-8 S-1
08/26/2009	Aqueous	0908-00130 008	GH-8 S-1 Dissolved Metals
08/26/2009	Aqueous	0908-00130 009	GH-8 S-2
08/26/2009	Aqueous	0908-00130 010	GH-8 S-2 Dissolved Metals
08/26/2009	Aqueous	0908-00130 011	GH-8 S-3
08/26/2009	Aqueous	0908-00130 012	GH-8 S-3 Dissolved Metals



ANALYTICAL REPORT

GZA GeoEnvironmental, Inc.
530 Broadway
Providence, RI 02909

Meg Kilpatrick

Project Name.: **Former Tidewater Facility**

Project No.: **03.0043654.00**

Date Received: **08/27/2009**

Date Reported: **09/10/2009**

Work Order No.: **0908-00130**

PROJECT NARRATIVE:

1. Sample Receipt

The samples were received on 08/27/09 via GZA courier, EC, FEDEX, or hand delivered. The temperature of the temperature blank/ cooler air, was 3.9 & 4.1 degrees C. The temperature requirement for most analyses is above freezing to 6 degrees C. The samples were received intact for all requested analyses.

The chain of custody indicates that the samples, when required, were chemically preserved in accordance with the method they reference.

2. Subcontracted Analyses

Analyses for TSS, Cyanide, Free Cyanide and Ferrous Iron were subcontracted to Rhode Island Analytical, Warwick RI (RIAL); Certification MA: MA-RI015, NH: 253700 A&B, CT: PH-0508, ME: RI015, RI: RI-033, NY:11726,

The data is included in GZA's report for ease of electronic data transfer and is indicated by "XXX" in the tech column. The data report from the subcontractor is attached.

3. EPA Method 300.0 - Anions

Attach QC 300.0 08/27/09

4. EPA Method 6010B/7470A - Metals

Attach QC 6010B 08/28/09 - Aqueous

Attach QC 7470A 08/28/09 - Aqueous

5. EPA Method 200.7 - Metals

Attach QC 200.7 08/28/09

6. EPA Method 8260 - VOCs

Attach QC 8260 08/31/09 S - Aqueous

7. EPA Method 8270 - PAHs

Attach QC 8270 09/01/09 - Aqueous



ANALYTICAL REPORT

GZA GeoEnvironmental, Inc.
530 Broadway
Providence, RI 02909

Meg Kilpatrick

Project Name.: **Former Tidewater Facility**

Project No.: **03.0043654.00**

Date Received: **08/27/2009**

Date Reported: **09/10/2009**

Work Order No.: **0908-00130**

Data Authorized By: _____

NELAC certification, as indicated by the NELAC Lab ID Number, is per analyte. For a complete list of NELAC validated analytes, please contact the laboratory.

Abbreviations:

% R = % Recovery
DF = Dilution Factor
DFS = Dilution Factor Solids
CF = Calculation Factor
DO = Diluted Out

Method Key:

Method 8260: The current version of the method is 8260B.
Method 8270: The current version of the method is 8270D.
Method 6010: The current version of the method is 6010B.

Please note that the laboratory signed copy of the chain of custody record is an integral part of the data report.

The laboratory report shall not be reproduced except in full without the written consent of the laboratory.

Soil data is reported on a dry weight basis unless otherwise specified.
Matrix Spike / Matrix Spike Duplicate sets are performed as per method and are reported at the end of the analytical report if assigned on the Chain of Custody.



ANALYTICAL REPORT

GZA GeoEnvironmental, Inc.
 530 Broadway
 Providence, RI 02909

Meg Kilpatrick

Project Name.: **Former Tidewater Facility**
 Project No.: **03.0043654.00**

Date Received: **08/27/2009**
 Date Reported: **09/10/2009**
 Work Order No.: **0908-00130**

Sample ID: **GH-7 S-1**
 Sample Date: **08/26/2009**

Sample No.: **001**

Test Performed	Method	Results	Reporting Limit	Units	Tech	Analysis Date
VOLATILE ORGANICS	EPA 8260				MQS	08/31/2009
Dichlorodifluoromethane	EPA 8260	<2.0	2.0	ug/L	MQS	08/31/2009
Chloromethane	EPA 8260	<2.0	2.0	ug/L	MQS	08/31/2009
Vinyl Chloride	EPA 8260	<1.0	1.0	ug/L	MQS	08/31/2009
Bromomethane	EPA 8260	<2.0	2.0	ug/L	MQS	08/31/2009
Chloroethane	EPA 8260	<1.0	1.0	ug/L	MQS	08/31/2009
Trichlorofluoromethane	EPA 8260	<2.0	2.0	ug/L	MQS	08/31/2009
Diethylether	EPA 8260	<5.0	5.0	ug/L	MQS	08/31/2009
Acetone	EPA 8260	<25	25	ug/L	MQS	08/31/2009
1,1-Dichloroethene	EPA 8260	<1.0	1.0	ug/L	MQS	08/31/2009
Dichloromethane	EPA 8260	<2.0	2.0	ug/L	MQS	08/31/2009
Methyl-Tert-Butyl-Ether	EPA 8260	<1.0	1.0	ug/L	MQS	08/31/2009
trans-1,2-Dichloroethene	EPA 8260	<1.0	1.0	ug/L	MQS	08/31/2009
1,1-Dichloroethane	EPA 8260	<1.0	1.0	ug/L	MQS	08/31/2009
2-Butanone	EPA 8260	<25	25	ug/L	MQS	08/31/2009
2,2-Dichloropropane	EPA 8260	<1.0	1.0	ug/L	MQS	08/31/2009
cis-1,2-Dichloroethene	EPA 8260	<1.0	1.0	ug/L	MQS	08/31/2009
Chloroform	EPA 8260	<1.0	1.0	ug/L	MQS	08/31/2009
Bromochloromethane	EPA 8260	<1.0	1.0	ug/L	MQS	08/31/2009
Tetrahydrofuran	EPA 8260	<10	10	ug/L	MQS	08/31/2009
1,1,1-Trichloroethane	EPA 8260	<1.0	1.0	ug/L	MQS	08/31/2009
1,1-Dichloropropene	EPA 8260	<1.0	1.0	ug/L	MQS	08/31/2009
Carbon Tetrachloride	EPA 8260	<1.0	1.0	ug/L	MQS	08/31/2009
1,2-Dichloroethane	EPA 8260	<1.0	1.0	ug/L	MQS	08/31/2009
Benzene	EPA 8260	9.5	1.0	ug/L	MQS	08/31/2009
Trichloroethene	EPA 8260	<1.0	1.0	ug/L	MQS	08/31/2009
1,2-Dichloropropane	EPA 8260	<1.0	1.0	ug/L	MQS	08/31/2009
Bromodichloromethane	EPA 8260	<1.0	1.0	ug/L	MQS	08/31/2009
Dibromomethane	EPA 8260	<1.0	1.0	ug/L	MQS	08/31/2009
4-Methyl-2-Pentanone	EPA 8260	<25	25	ug/L	MQS	08/31/2009
cis-1,3-Dichloropropene	EPA 8260	<1.0	1.0	ug/L	MQS	08/31/2009
Toluene	EPA 8260	78	1.0	ug/L	MQS	08/31/2009
trans-1,3-Dichloropropene	EPA 8260	<2.0	2.0	ug/L	MQS	08/31/2009
1,1,2-Trichloroethane	EPA 8260	<1.0	1.0	ug/L	MQS	08/31/2009
2-Hexanone	EPA 8260	<25	25	ug/L	MQS	08/31/2009



ANALYTICAL REPORT

GZA GeoEnvironmental, Inc.
 530 Broadway
 Providence, RI 02909

Meg Kilpatrick

Project Name.: **Former Tidewater Facility**
 Project No.: **03.0043654.00**

Date Received: **08/27/2009**
 Date Reported: **09/10/2009**
 Work Order No.: **0908-00130**

Sample ID: **GH-7 S-1**
 Sample Date: **08/26/2009**

Sample No.: **001**

Test Performed	Method	Results	Reporting Limit	Units	Tech	Analysis Date
1,3-Dichloropropane	EPA 8260	<1.0	1.0	ug/L	MQS	08/31/2009
Tetrachloroethene	EPA 8260	<1.0	1.0	ug/L	MQS	08/31/2009
Dibromochloromethane	EPA 8260	<1.0	1.0	ug/L	MQS	08/31/2009
1,2-Dibromoethane (EDB)	EPA 8260	<2.0	2.0	ug/L	MQS	08/31/2009
Chlorobenzene	EPA 8260	<1.0	1.0	ug/L	MQS	08/31/2009
1,1,1,2-Tetrachloroethane	EPA 8260	<1.0	1.0	ug/L	MQS	08/31/2009
Ethylbenzene	EPA 8260	21	1.0	ug/L	MQS	08/31/2009
m&p-Xylene	EPA 8260	150	2.0	ug/L	MQS	08/31/2009
o-Xylene	EPA 8260	62	1.0	ug/L	MQS	08/31/2009
Styrene	EPA 8260	8.1	1.0	ug/L	MQS	08/31/2009
Bromoform	EPA 8260	<2.0	2.0	ug/L	MQS	08/31/2009
Isopropylbenzene	EPA 8260	2.2	1.0	ug/L	MQS	08/31/2009
1,1,2,2-Tetrachloroethane	EPA 8260	<1.0	1.0	ug/L	MQS	08/31/2009
1,2,3-Trichloropropane	EPA 8260	<1.0	1.0	ug/L	MQS	08/31/2009
Bromobenzene	EPA 8260	<1.0	1.0	ug/L	MQS	08/31/2009
N-Propylbenzene	EPA 8260	<1.0	1.0	ug/L	MQS	08/31/2009
2-Chlorotoluene	EPA 8260	<1.0	1.0	ug/L	MQS	08/31/2009
1,3,5-Trimethylbenzene	EPA 8260	23	1.0	ug/L	MQS	08/31/2009
4-Chlorotoluene	EPA 8260	<1.0	1.0	ug/L	MQS	08/31/2009
tert-Butylbenzene	EPA 8260	<1.0	1.0	ug/L	MQS	08/31/2009
1,2,4-Trimethylbenzene	EPA 8260	51	1.0	ug/L	MQS	08/31/2009
sec-Butylbenzene	EPA 8260	<1.0	1.0	ug/L	MQS	08/31/2009
p-Isopropyltoluene	EPA 8260	1.4	1.0	ug/L	MQS	08/31/2009
1,3-Dichlorobenzene	EPA 8260	<1.0	1.0	ug/L	MQS	08/31/2009
1,4-Dichlorobenzene	EPA 8260	<1.0	1.0	ug/L	MQS	08/31/2009
n-Butylbenzene	EPA 8260	<1.0	1.0	ug/L	MQS	08/31/2009
1,2-Dichlorobenzene	EPA 8260	<1.0	1.0	ug/L	MQS	08/31/2009
1,2-Dibromo-3-Chloropropane	EPA 8260	<5.0	5.0	ug/L	MQS	08/31/2009
1,2,4-Trichlorobenzene	EPA 8260	<1.0	1.0	ug/L	MQS	08/31/2009
Hexachlorobutadiene	EPA 8260	<1.0	1.0	ug/L	MQS	08/31/2009
Naphthalene	EPA 8260	37	2.0	ug/L	MQS	08/31/2009
1,2,3-Trichlorobenzene	EPA 8260	<1.0	1.0	ug/L	MQS	08/31/2009
Surrogates:	EPA 8260					
***1,2-Dichloroethane-D4	EPA 8260	103	70-130	% R	MQS	08/31/2009
***Toluene-D8	EPA 8260	100	70-130	% R	MQS	08/31/2009



ANALYTICAL REPORT

GZA GeoEnvironmental, Inc.
 530 Broadway
 Providence, RI 02909

Meg Kilpatrick

Project Name.: **Former Tidewater Facility**
 Project No.: **03.0043654.00**

Date Received: **08/27/2009**
 Date Reported: **09/10/2009**
 Work Order No.: **0908-00130**

Sample ID: **GH-7 S-1**
 Sample Date: **08/26/2009**

Sample No.: **001**

Test Performed	Method	Results	Reporting Limit	Units	Tech	Analysis Date
***4-Bromofluorobenzene	EPA 8260	100	70-130	% R	MQS	08/31/2009
Preparation	EPA 5030B	1.0		CF	MQS	08/31/2009
PAHS BY GCMS	EPA 8270				CMG	09/09/2009
Naphthalene	EPA 8270	11	2.0	ug/L	CMG	09/09/2009
2-Methylnaphthalene	EPA 8270	<2.0	2.0	ug/L	CMG	09/09/2009
Acenaphthylene	EPA 8270	<2.0	2.0	ug/L	CMG	09/09/2009
Acenaphthene	EPA 8270	<2.0	2.0	ug/L	CMG	09/09/2009
Fluorene	EPA 8270	<2.0	2.0	ug/L	CMG	09/09/2009
Phenanthrene	EPA 8270	<2.0	2.0	ug/L	CMG	09/09/2009
Anthracene	EPA 8270	<2.0	2.0	ug/L	CMG	09/09/2009
Fluoranthene	EPA 8270	<2.0	2.0	ug/L	CMG	09/09/2009
Pyrene	EPA 8270	<2.0	2.0	ug/L	CMG	09/09/2009
Benzo [a] Anthracene	EPA 8270	<2.0	2.0	ug/L	CMG	09/09/2009
Chrysene	EPA 8270	<2.0	2.0	ug/L	CMG	09/09/2009
Benzo [b] Fluoranthene	EPA 8270	<2.0	2.0	ug/L	CMG	09/09/2009
Benzo [k] Fluoranthene	EPA 8270	<2.0	2.0	ug/L	CMG	09/09/2009
Benzo [a] Pyrene	EPA 8270	<2.0	2.0	ug/L	CMG	09/09/2009
Indeno [1,2,3-cd] Pyrene	EPA 8270	<2.0	2.0	ug/L	CMG	09/09/2009
Dibenzo [a,h] Anthracene	EPA 8270	<2.0	2.0	ug/L	CMG	09/09/2009
Benzo [g,h,i] Perylene	EPA 8270	<2.0	2.0	ug/L	CMG	09/09/2009
Surrogates:	EPA 8270					
***Nitrobenzene-D5	EPA 8270	38.8	30-130	% R	CMG	09/09/2009
***2-Fluorobiphenyl	EPA 8270	41.3	30-130	% R	CMG	09/09/2009
***P-Terphenyl-D14	EPA 8270	52.2	30-130	% R	CMG	09/09/2009
Extraction	EPA 3510C	1.0		DF	KEF	09/01/2009
TOTAL PETROLEUM HYDROCARBON	Mod. EPA 8100				RJD	09/01/2009
Hydrocarbon Content		810	200	ug/L	RJD	09/01/2009
Surrogate:						
***p-Terphenyl		51.8	40-130	% R	RJD	09/01/2009
Extraction	EPA 3510C	1.0		DF	NOG	08/28/2009
METALS						
Arsenic	EPA 6010B	<0.010	0.010	mg/L	LLZ	08/28/2009
Antimony	EPA 6010B	<0.025	0.025	mg/L	LLZ	08/28/2009
Cadmium	EPA 6010B	<0.0050	0.0050	mg/L	LLZ	08/28/2009
Chromium	EPA 6010B	<0.0050	0.0050	mg/L	LLZ	08/28/2009



ANALYTICAL REPORT

GZA GeoEnvironmental, Inc.
 530 Broadway
 Providence, RI 02909

Meg Kilpatrick

Project Name.: **Former Tidewater Facility**
 Project No.: **03.0043654.00**

Date Received: **08/27/2009**
 Date Reported: **09/10/2009**
 Work Order No.: **0908-00130**

Sample ID: **GH-7 S-1**
 Sample Date: **08/26/2009**

Sample No.: **001**

Test Performed	Method	Results	Reporting Limit	Units	Tech	Analysis Date
Copper	EPA 6010B	0.016	0.015	mg/L	LLZ	08/28/2009
Lead	EPA 6010B	0.024	0.010	mg/L	LLZ	08/28/2009
Nickel	EPA 6010B	<0.010	0.010	mg/L	LLZ	08/28/2009
Selenium	EPA 6010B	<0.025	0.025	mg/L	LLZ	08/28/2009
Silver	EPA 6010B	<0.0050	0.0050	mg/L	LLZ	08/28/2009
Iron	EPA 6010B	1.7	0.025	mg/L	LLZ	08/28/2009
Manganese	EPA 6010B	0.27	0.0050	mg/L	LLZ	08/28/2009
Zinc	EPA 6010B	0.016	0.010	mg/L	LLZ	08/28/2009
Mercury	EPA 7470A	<0.00040	0.00040	mg/L	AJY	08/31/2009
HARDNESS	EPA 200.7	1.6		mg CaCO ₃ /L	LLZ	08/28/2009
Calcium	EPA 200.7	0.38	0.025	mg/L	LLZ	08/28/2009
Magnesium	EPA 200.7	0.15	0.025	mg/L	LLZ	08/28/2009
ANIONS - ION CHROMATOGRAPHY	EPA 300.0				TAJ	08/27/2009
Sulfate	EPA 300.0	<0.60	0.60	mg/L	TAJ	08/27/2009
Ferric Iron	HACH	1.7		mg/L	AJY	09/09/2009
SUBCONTRACTED ANALYTES						
Ferrous Iron	SM-3500-FE D	<0.40	0.10	mg/L	XXX	08/26/2009
Total Suspended Solids	SM-2540D	2.0	2.0	mg/L	XXX	08/27/2009
Total Cyanide	SM-4500CN-C E	0.06	0.01	mg/L	XXX	09/01/2009
Free Cyanide	SM4500-CN,H	<0.01	0.01	mg/L	XXX	08/28/2009



ANALYTICAL REPORT

GZA GeoEnvironmental, Inc.
 530 Broadway
 Providence, RI 02909

Meg Kilpatrick

Project Name.: **Former Tidewater Facility**
 Project No.: **03.0043654.00**

Date Received: **08/27/2009**
 Date Reported: **09/10/2009**
 Work Order No.: **0908-00130**

Sample ID: **GH-7 S-1 Dissolved Metals**

Sample No.: **002**

Sample Date: **08/26/2009**

Test Performed	Method	Results	Reporting Limit	Units	Tech	Analysis Date
DISSOLVED METALS						
Arsenic	EPA 6010B	<0.010	0.010	mg/L	LLZ	08/28/2009
Antimony	EPA 6010B	<0.025	0.025	mg/L	LLZ	08/28/2009
Cadmium	EPA 6010B	<0.0050	0.0050	mg/L	LLZ	08/28/2009
Chromium	EPA 6010B	<0.0050	0.0050	mg/L	LLZ	08/28/2009
Copper	EPA 6010B	0.016	0.015	mg/L	LLZ	08/28/2009
Lead	EPA 6010B	0.015	0.010	mg/L	LLZ	08/28/2009
Nickel	EPA 6010B	<0.010	0.010	mg/L	LLZ	08/28/2009
Selenium	EPA 6010B	<0.025	0.025	mg/L	LLZ	08/28/2009
Silver	EPA 6010B	<0.0050	0.0050	mg/L	LLZ	08/28/2009
Iron	EPA 6010B	0.29	0.025	mg/L	LLZ	08/28/2009
Manganese	EPA 6010B	0.27	0.0050	mg/L	LLZ	08/28/2009
Zinc	EPA 6010B	0.015	0.010	mg/L	LLZ	08/28/2009
Mercury	EPA 7470A	<0.00040	0.00040	mg/L	AJY	08/31/2009



ANALYTICAL REPORT

GZA GeoEnvironmental, Inc.
530 Broadway
Providence, RI 02909

Meg Kilpatrick

Project Name.: **Former Tidewater Facility**
Project No.: **03.0043654.00**

Date Received: **08/27/2009**
Date Reported: **09/10/2009**
Work Order No.: **0908-00130**

Sample ID: **GH-7 S-2**
Sample Date: **08/26/2009**

Sample No.: **003**

Test Performed	Method	Results	Reporting Limit	Units	Tech	Analysis Date
VOLATILE ORGANICS	EPA 8260				MQS	08/31/2009
Dichlorodifluoromethane	EPA 8260	<2.0	2.0	ug/L	MQS	08/31/2009
Chloromethane	EPA 8260	<2.0	2.0	ug/L	MQS	08/31/2009
Vinyl Chloride	EPA 8260	<1.0	1.0	ug/L	MQS	08/31/2009
Bromomethane	EPA 8260	<2.0	2.0	ug/L	MQS	08/31/2009
Chloroethane	EPA 8260	<1.0	1.0	ug/L	MQS	08/31/2009
Trichlorofluoromethane	EPA 8260	<2.0	2.0	ug/L	MQS	08/31/2009
Diethylether	EPA 8260	<5.0	5.0	ug/L	MQS	08/31/2009
Acetone	EPA 8260	<25	25	ug/L	MQS	08/31/2009
1,1-Dichloroethene	EPA 8260	<1.0	1.0	ug/L	MQS	08/31/2009
Dichloromethane	EPA 8260	<2.0	2.0	ug/L	MQS	08/31/2009
Methyl-Tert-Butyl-Ether	EPA 8260	<1.0	1.0	ug/L	MQS	08/31/2009
trans-1,2-Dichloroethene	EPA 8260	<1.0	1.0	ug/L	MQS	08/31/2009
1,1-Dichloroethane	EPA 8260	<1.0	1.0	ug/L	MQS	08/31/2009
2-Butanone	EPA 8260	<25	25	ug/L	MQS	08/31/2009
2,2-Dichloropropane	EPA 8260	<1.0	1.0	ug/L	MQS	08/31/2009
cis-1,2-Dichloroethene	EPA 8260	<1.0	1.0	ug/L	MQS	08/31/2009
Chloroform	EPA 8260	<1.0	1.0	ug/L	MQS	08/31/2009
Bromochloromethane	EPA 8260	<1.0	1.0	ug/L	MQS	08/31/2009
Tetrahydrofuran	EPA 8260	<10	10	ug/L	MQS	08/31/2009
1,1,1-Trichloroethane	EPA 8260	<1.0	1.0	ug/L	MQS	08/31/2009
1,1-Dichloropropene	EPA 8260	<1.0	1.0	ug/L	MQS	08/31/2009
Carbon Tetrachloride	EPA 8260	<1.0	1.0	ug/L	MQS	08/31/2009
1,2-Dichloroethane	EPA 8260	<1.0	1.0	ug/L	MQS	08/31/2009
Benzene	EPA 8260	8.6	1.0	ug/L	MQS	08/31/2009
Trichloroethene	EPA 8260	<1.0	1.0	ug/L	MQS	08/31/2009
1,2-Dichloropropane	EPA 8260	<1.0	1.0	ug/L	MQS	08/31/2009
Bromodichloromethane	EPA 8260	<1.0	1.0	ug/L	MQS	08/31/2009
Dibromomethane	EPA 8260	<1.0	1.0	ug/L	MQS	08/31/2009
4-Methyl-2-Pentanone	EPA 8260	<25	25	ug/L	MQS	08/31/2009
cis-1,3-Dichloropropene	EPA 8260	<1.0	1.0	ug/L	MQS	08/31/2009
Toluene	EPA 8260	86	1.0	ug/L	MQS	08/31/2009
trans-1,3-Dichloropropene	EPA 8260	<2.0	2.0	ug/L	MQS	08/31/2009
1,1,2-Trichloroethane	EPA 8260	<1.0	1.0	ug/L	MQS	08/31/2009
2-Hexanone	EPA 8260	<25	25	ug/L	MQS	08/31/2009



ANALYTICAL REPORT

GZA GeoEnvironmental, Inc.
 530 Broadway
 Providence, RI 02909

Meg Kilpatrick

Project Name.: **Former Tidewater Facility**
 Project No.: **03.0043654.00**

Date Received: **08/27/2009**
 Date Reported: **09/10/2009**
 Work Order No.: **0908-00130**

Sample ID: **GH-7 S-2**
 Sample Date: **08/26/2009**

Sample No.: **003**

Test Performed	Method	Results	Reporting Limit	Units	Tech	Analysis Date
1,3-Dichloropropane	EPA 8260	<1.0	1.0	ug/L	MQS	08/31/2009
Tetrachloroethene	EPA 8260	<1.0	1.0	ug/L	MQS	08/31/2009
Dibromochloromethane	EPA 8260	<1.0	1.0	ug/L	MQS	08/31/2009
1,2-Dibromoethane (EDB)	EPA 8260	<2.0	2.0	ug/L	MQS	08/31/2009
Chlorobenzene	EPA 8260	<1.0	1.0	ug/L	MQS	08/31/2009
1,1,1,2-Tetrachloroethane	EPA 8260	<1.0	1.0	ug/L	MQS	08/31/2009
Ethylbenzene	EPA 8260	27	1.0	ug/L	MQS	08/31/2009
m&p-Xylene	EPA 8260	160	2.0	ug/L	MQS	08/31/2009
o-Xylene	EPA 8260	67	1.0	ug/L	MQS	08/31/2009
Styrene	EPA 8260	8.9	1.0	ug/L	MQS	08/31/2009
Bromoform	EPA 8260	<2.0	2.0	ug/L	MQS	08/31/2009
Isopropylbenzene	EPA 8260	2.6	1.0	ug/L	MQS	08/31/2009
1,1,2,2-Tetrachloroethane	EPA 8260	<1.0	1.0	ug/L	MQS	08/31/2009
1,2,3-Trichloropropane	EPA 8260	<1.0	1.0	ug/L	MQS	08/31/2009
Bromobenzene	EPA 8260	<1.0	1.0	ug/L	MQS	08/31/2009
N-Propylbenzene	EPA 8260	<1.0	1.0	ug/L	MQS	08/31/2009
2-Chlorotoluene	EPA 8260	<1.0	1.0	ug/L	MQS	08/31/2009
1,3,5-Trimethylbenzene	EPA 8260	25	1.0	ug/L	MQS	08/31/2009
4-Chlorotoluene	EPA 8260	<1.0	1.0	ug/L	MQS	08/31/2009
tert-Butylbenzene	EPA 8260	<1.0	1.0	ug/L	MQS	08/31/2009
1,2,4-Trimethylbenzene	EPA 8260	56	1.0	ug/L	MQS	08/31/2009
sec-Butylbenzene	EPA 8260	<1.0	1.0	ug/L	MQS	08/31/2009
p-Isopropyltoluene	EPA 8260	1.5	1.0	ug/L	MQS	08/31/2009
1,3-Dichlorobenzene	EPA 8260	<1.0	1.0	ug/L	MQS	08/31/2009
1,4-Dichlorobenzene	EPA 8260	<1.0	1.0	ug/L	MQS	08/31/2009
n-Butylbenzene	EPA 8260	<1.0	1.0	ug/L	MQS	08/31/2009
1,2-Dichlorobenzene	EPA 8260	<1.0	1.0	ug/L	MQS	08/31/2009
1,2-Dibromo-3-Chloropropane	EPA 8260	<5.0	5.0	ug/L	MQS	08/31/2009
1,2,4-Trichlorobenzene	EPA 8260	<1.0	1.0	ug/L	MQS	08/31/2009
Hexachlorobutadiene	EPA 8260	<1.0	1.0	ug/L	MQS	08/31/2009
Naphthalene	EPA 8260	47	2.0	ug/L	MQS	08/31/2009
1,2,3-Trichlorobenzene	EPA 8260	<1.0	1.0	ug/L	MQS	08/31/2009
Surrogates:	EPA 8260					
***1,2-Dichloroethane-D4	EPA 8260	99.4	70-130	% R	MQS	08/31/2009
***Toluene-D8	EPA 8260	99.9	70-130	% R	MQS	08/31/2009



ANALYTICAL REPORT

GZA GeoEnvironmental, Inc.
 530 Broadway
 Providence, RI 02909

Meg Kilpatrick

Project Name.: **Former Tidewater Facility**
 Project No.: **03.0043654.00**

Date Received: **08/27/2009**
 Date Reported: **09/10/2009**
 Work Order No.: **0908-00130**

Sample ID: **GH-7 S-2**
 Sample Date: **08/26/2009**

Sample No.: **003**

Test Performed	Method	Results	Reporting Limit	Units	Tech	Analysis Date
***4-Bromofluorobenzene	EPA 8260	100	70-130	% R	MQS	08/31/2009
Preparation	EPA 5030B	1.0		CF	MQS	08/31/2009
PAHS BY GCMS	EPA 8270				CMG	09/09/2009
Naphthalene	EPA 8270	15	2.0	ug/L	CMG	09/09/2009
2-Methylnaphthalene	EPA 8270	<2.0	2.0	ug/L	CMG	09/09/2009
Acenaphthylene	EPA 8270	<2.0	2.0	ug/L	CMG	09/09/2009
Acenaphthene	EPA 8270	<2.0	2.0	ug/L	CMG	09/09/2009
Fluorene	EPA 8270	<2.0	2.0	ug/L	CMG	09/09/2009
Phenanthrene	EPA 8270	<2.0	2.0	ug/L	CMG	09/09/2009
Anthracene	EPA 8270	<2.0	2.0	ug/L	CMG	09/09/2009
Fluoranthene	EPA 8270	<2.0	2.0	ug/L	CMG	09/09/2009
Pyrene	EPA 8270	<2.0	2.0	ug/L	CMG	09/09/2009
Benzo [a] Anthracene	EPA 8270	<2.0	2.0	ug/L	CMG	09/09/2009
Chrysene	EPA 8270	<2.0	2.0	ug/L	CMG	09/09/2009
Benzo [b] Fluoranthene	EPA 8270	<2.0	2.0	ug/L	CMG	09/09/2009
Benzo [k] Fluoranthene	EPA 8270	<2.0	2.0	ug/L	CMG	09/09/2009
Benzo [a] Pyrene	EPA 8270	<2.0	2.0	ug/L	CMG	09/09/2009
Indeno [1,2,3-cd] Pyrene	EPA 8270	<2.0	2.0	ug/L	CMG	09/09/2009
Dibenzo [a,h] Anthracene	EPA 8270	<2.0	2.0	ug/L	CMG	09/09/2009
Benzo [g,h,i] Perylene	EPA 8270	<2.0	2.0	ug/L	CMG	09/09/2009
Surrogates:	EPA 8270					
***Nitrobenzene-D5	EPA 8270	37.8	30-130	% R	CMG	09/09/2009
***2-Fluorobiphenyl	EPA 8270	39.2	30-130	% R	CMG	09/09/2009
***P-Terphenyl-D14	EPA 8270	47.0	30-130	% R	CMG	09/09/2009
Extraction	EPA 3510C	1.0		DF	KEF	09/01/2009
TOTAL PETROLEUM HYDROCARBON	Mod. EPA 8100				RJD	09/01/2009
Hydrocarbon Content		840	200	ug/L	RJD	09/01/2009
Surrogate:						
***p-Terphenyl		54.0	40-130	% R	RJD	09/01/2009
Extraction	EPA 3510C	1.0		DF	NOG	08/28/2009
METALS						
Arsenic	EPA 6010B	<0.010	0.010	mg/L	LLZ	08/28/2009
Antimony	EPA 6010B	<0.025	0.025	mg/L	LLZ	08/28/2009
Cadmium	EPA 6010B	<0.0050	0.0050	mg/L	LLZ	08/28/2009
Chromium	EPA 6010B	<0.0050	0.0050	mg/L	LLZ	08/28/2009



ANALYTICAL REPORT

GZA GeoEnvironmental, Inc.
 530 Broadway
 Providence, RI 02909

Meg Kilpatrick

Project Name.: **Former Tidewater Facility**
 Project No.: **03.0043654.00**

Date Received: **08/27/2009**
 Date Reported: **09/10/2009**
 Work Order No.: **0908-00130**

Sample ID: **GH-7 S-2**
 Sample Date: **08/26/2009**

Sample No.: **003**

Test Performed	Method	Results	Reporting Limit	Units	Tech	Analysis Date
Copper	EPA 6010B	0.016	0.015	mg/L	LLZ	08/28/2009
Lead	EPA 6010B	0.026	0.010	mg/L	LLZ	08/28/2009
Nickel	EPA 6010B	<0.010	0.010	mg/L	LLZ	08/28/2009
Selenium	EPA 6010B	<0.025	0.025	mg/L	LLZ	08/28/2009
Silver	EPA 6010B	<0.0050	0.0050	mg/L	LLZ	08/28/2009
Iron	EPA 6010B	1.8	0.025	mg/L	LLZ	08/28/2009
Manganese	EPA 6010B	0.27	0.0050	mg/L	LLZ	08/28/2009
Zinc	EPA 6010B	0.015	0.010	mg/L	LLZ	08/28/2009
Mercury	EPA 7470A	<0.00040	0.00040	mg/L	AJY	08/31/2009
HARDNESS	EPA 200.7	1.6		mg CaCO ₃ /L	LLZ	08/28/2009
Calcium	EPA 200.7	0.45	0.025	mg/L	LLZ	08/28/2009
Magnesium	EPA 200.7	0.14	0.025	mg/L	LLZ	08/28/2009
ANIONS - ION CHROMATOGRAPHY	EPA 300.0				TAJ	08/27/2009
Sulfate	EPA 300.0	<0.60	0.60	mg/L	TAJ	08/27/2009
Ferric Iron	HACH	1.8		mg/L	AJY	09/09/2009
SUBCONTRACTED ANALYTES						
Ferrous Iron	SM-3500-FE D	<0.40	0.40	mg/L	XXX	08/26/2009
Total Suspended Solids	SM-2540D	<2.0	2.0	mg/L	XXX	08/27/2009
Total Cyanide	SM-4500CN-C E	0.04	0.01	mg/L	XXX	09/01/2009
Free Cyanide	SM4500-CN,H	<0.01	0.01	mg/L	XXX	08/28/2009



ANALYTICAL REPORT

GZA GeoEnvironmental, Inc.
 530 Broadway
 Providence, RI 02909

Meg Kilpatrick

Project Name.: **Former Tidewater Facility**
 Project No.: **03.0043654.00**

Date Received: **08/27/2009**
 Date Reported: **09/10/2009**
 Work Order No.: **0908-00130**

Sample ID: **GH-7 S-2 Dissolved Metals**
 Sample Date: **08/26/2009**

Sample No.: **004**

Test Performed	Method	Results	Reporting Limit	Units	Tech	Analysis Date
DISSOLVED METALS						
Arsenic	EPA 6010B	<0.010	0.010	mg/L	LLZ	08/28/2009
Antimony	EPA 6010B	<0.025	0.025	mg/L	LLZ	08/28/2009
Cadmium	EPA 6010B	<0.0050	0.0050	mg/L	LLZ	08/28/2009
Chromium	EPA 6010B	<0.0050	0.0050	mg/L	LLZ	08/28/2009
Copper	EPA 6010B	0.016	0.015	mg/L	LLZ	08/28/2009
Lead	EPA 6010B	0.010	0.010	mg/L	LLZ	08/28/2009
Nickel	EPA 6010B	<0.010	0.010	mg/L	LLZ	08/28/2009
Selenium	EPA 6010B	<0.025	0.025	mg/L	LLZ	08/28/2009
Silver	EPA 6010B	<0.0050	0.0050	mg/L	LLZ	08/28/2009
Iron	EPA 6010B	0.54	0.025	mg/L	LLZ	08/28/2009
Manganese	EPA 6010B	0.27	0.0050	mg/L	LLZ	08/28/2009
Zinc	EPA 6010B	0.017	0.010	mg/L	LLZ	08/28/2009
Mercury	EPA 7470A	<0.00040	0.00040	mg/L	AJY	08/31/2009



ANALYTICAL REPORT

GZA GeoEnvironmental, Inc.
 530 Broadway
 Providence, RI 02909

Meg Kilpatrick

Project Name.: **Former Tidewater Facility**
 Project No.: **03.0043654.00**

Date Received: **08/27/2009**
 Date Reported: **09/10/2009**
 Work Order No.: **0908-00130**

Sample ID: **GH-7 S-3**
 Sample Date: **08/26/2009**

Sample No.: **005**

Test Performed	Method	Results	Reporting Limit	Units	Tech	Analysis Date
VOLATILE ORGANICS	EPA 8260				MQS	08/31/2009
Dichlorodifluoromethane	EPA 8260	<2.0	2.0	ug/L	MQS	08/31/2009
Chloromethane	EPA 8260	<2.0	2.0	ug/L	MQS	08/31/2009
Vinyl Chloride	EPA 8260	<1.0	1.0	ug/L	MQS	08/31/2009
Bromomethane	EPA 8260	<2.0	2.0	ug/L	MQS	08/31/2009
Chloroethane	EPA 8260	<1.0	1.0	ug/L	MQS	08/31/2009
Trichlorofluoromethane	EPA 8260	<2.0	2.0	ug/L	MQS	08/31/2009
Diethylether	EPA 8260	<5.0	5.0	ug/L	MQS	08/31/2009
Acetone	EPA 8260	<25	25	ug/L	MQS	08/31/2009
1,1-Dichloroethene	EPA 8260	<1.0	1.0	ug/L	MQS	08/31/2009
Dichloromethane	EPA 8260	<2.0	2.0	ug/L	MQS	08/31/2009
Methyl-Tert-Butyl-Ether	EPA 8260	<1.0	1.0	ug/L	MQS	08/31/2009
trans-1,2-Dichloroethene	EPA 8260	<1.0	1.0	ug/L	MQS	08/31/2009
1,1-Dichloroethane	EPA 8260	<1.0	1.0	ug/L	MQS	08/31/2009
2-Butanone	EPA 8260	<25	25	ug/L	MQS	08/31/2009
2,2-Dichloropropane	EPA 8260	<1.0	1.0	ug/L	MQS	08/31/2009
cis-1,2-Dichloroethene	EPA 8260	<1.0	1.0	ug/L	MQS	08/31/2009
Chloroform	EPA 8260	<1.0	1.0	ug/L	MQS	08/31/2009
Bromochloromethane	EPA 8260	<1.0	1.0	ug/L	MQS	08/31/2009
Tetrahydrofuran	EPA 8260	<10	10	ug/L	MQS	08/31/2009
1,1,1-Trichloroethane	EPA 8260	<1.0	1.0	ug/L	MQS	08/31/2009
1,1-Dichloropropene	EPA 8260	<1.0	1.0	ug/L	MQS	08/31/2009
Carbon Tetrachloride	EPA 8260	<1.0	1.0	ug/L	MQS	08/31/2009
1,2-Dichloroethane	EPA 8260	<1.0	1.0	ug/L	MQS	08/31/2009
Benzene	EPA 8260	3.8	1.0	ug/L	MQS	08/31/2009
Trichloroethene	EPA 8260	<1.0	1.0	ug/L	MQS	08/31/2009
1,2-Dichloropropane	EPA 8260	<1.0	1.0	ug/L	MQS	08/31/2009
Bromodichloromethane	EPA 8260	<1.0	1.0	ug/L	MQS	08/31/2009
Dibromomethane	EPA 8260	<1.0	1.0	ug/L	MQS	08/31/2009
4-Methyl-2-Pentanone	EPA 8260	<25	25	ug/L	MQS	08/31/2009
cis-1,3-Dichloropropene	EPA 8260	<1.0	1.0	ug/L	MQS	08/31/2009
Toluene	EPA 8260	83	1.0	ug/L	MQS	08/31/2009
trans-1,3-Dichloropropene	EPA 8260	<2.0	2.0	ug/L	MQS	08/31/2009
1,1,2-Trichloroethane	EPA 8260	<1.0	1.0	ug/L	MQS	08/31/2009
2-Hexanone	EPA 8260	<25	25	ug/L	MQS	08/31/2009



ANALYTICAL REPORT

GZA GeoEnvironmental, Inc.
 530 Broadway
 Providence, RI 02909

Meg Kilpatrick

Project Name.: **Former Tidewater Facility**
 Project No.: **03.0043654.00**

Date Received: **08/27/2009**
 Date Reported: **09/10/2009**
 Work Order No.: **0908-00130**

Sample ID: **GH-7 S-3**
 Sample Date: **08/26/2009**

Sample No.: **005**

Test Performed	Method	Results	Reporting Limit	Units	Tech	Analysis Date
1,3-Dichloropropane	EPA 8260	<1.0	1.0	ug/L	MQS	08/31/2009
Tetrachloroethene	EPA 8260	<1.0	1.0	ug/L	MQS	08/31/2009
Dibromochloromethane	EPA 8260	<1.0	1.0	ug/L	MQS	08/31/2009
1,2-Dibromoethane (EDB)	EPA 8260	<2.0	2.0	ug/L	MQS	08/31/2009
Chlorobenzene	EPA 8260	<1.0	1.0	ug/L	MQS	08/31/2009
1,1,1,2-Tetrachloroethane	EPA 8260	<1.0	1.0	ug/L	MQS	08/31/2009
Ethylbenzene	EPA 8260	26	1.0	ug/L	MQS	08/31/2009
m&p-Xylene	EPA 8260	160	2.0	ug/L	MQS	08/31/2009
o-Xylene	EPA 8260	69	1.0	ug/L	MQS	08/31/2009
Styrene	EPA 8260	8.4	1.0	ug/L	MQS	08/31/2009
Bromoform	EPA 8260	<2.0	2.0	ug/L	MQS	08/31/2009
Isopropylbenzene	EPA 8260	2.7	1.0	ug/L	MQS	08/31/2009
1,1,2,2-Tetrachloroethane	EPA 8260	<1.0	1.0	ug/L	MQS	08/31/2009
1,2,3-Trichloropropane	EPA 8260	<1.0	1.0	ug/L	MQS	08/31/2009
Bromobenzene	EPA 8260	<1.0	1.0	ug/L	MQS	08/31/2009
N-Propylbenzene	EPA 8260	<1.0	1.0	ug/L	MQS	08/31/2009
2-Chlorotoluene	EPA 8260	<1.0	1.0	ug/L	MQS	08/31/2009
1,3,5-Trimethylbenzene	EPA 8260	26	1.0	ug/L	MQS	08/31/2009
4-Chlorotoluene	EPA 8260	<1.0	1.0	ug/L	MQS	08/31/2009
tert-Butylbenzene	EPA 8260	<1.0	1.0	ug/L	MQS	08/31/2009
1,2,4-Trimethylbenzene	EPA 8260	59	1.0	ug/L	MQS	08/31/2009
sec-Butylbenzene	EPA 8260	<1.0	1.0	ug/L	MQS	08/31/2009
p-Isopropyltoluene	EPA 8260	1.6	1.0	ug/L	MQS	08/31/2009
1,3-Dichlorobenzene	EPA 8260	<1.0	1.0	ug/L	MQS	08/31/2009
1,4-Dichlorobenzene	EPA 8260	<1.0	1.0	ug/L	MQS	08/31/2009
n-Butylbenzene	EPA 8260	<1.0	1.0	ug/L	MQS	08/31/2009
1,2-Dichlorobenzene	EPA 8260	<1.0	1.0	ug/L	MQS	08/31/2009
1,2-Dibromo-3-Chloropropane	EPA 8260	<5.0	5.0	ug/L	MQS	08/31/2009
1,2,4-Trichlorobenzene	EPA 8260	<1.0	1.0	ug/L	MQS	08/31/2009
Hexachlorobutadiene	EPA 8260	<1.0	1.0	ug/L	MQS	08/31/2009
Naphthalene	EPA 8260	48	2.0	ug/L	MQS	08/31/2009
1,2,3-Trichlorobenzene	EPA 8260	<1.0	1.0	ug/L	MQS	08/31/2009
Surrogates:	EPA 8260					
***1,2-Dichloroethane-D4	EPA 8260	100	70-130	% R	MQS	08/31/2009
***Toluene-D8	EPA 8260	101	70-130	% R	MQS	08/31/2009



ANALYTICAL REPORT

GZA GeoEnvironmental, Inc.
 530 Broadway
 Providence, RI 02909

Meg Kilpatrick

Project Name.: **Former Tidewater Facility**
 Project No.: **03.0043654.00**

Date Received: **08/27/2009**
 Date Reported: **09/10/2009**
 Work Order No.: **0908-00130**

Sample ID: **GH-7 S-3**
 Sample Date: **08/26/2009**

Sample No.: **005**

Test Performed	Method	Results	Reporting Limit	Units	Tech	Analysis Date
**4-Bromofluorobenzene	EPA 8260	103	70-130	% R	MQS	08/31/2009
Preparation	EPA 5030B	1.0		CF	MQS	08/31/2009
PAHS BY GCMS	EPA 8270				CMG	09/09/2009
Naphthalene	EPA 8270	17	2.0	ug/L	CMG	09/09/2009
2-Methylnaphthalene	EPA 8270	2.6	2.0	ug/L	CMG	09/09/2009
Acenaphthylene	EPA 8270	<2.0	2.0	ug/L	CMG	09/09/2009
Acenaphthene	EPA 8270	<2.0	2.0	ug/L	CMG	09/09/2009
Fluorene	EPA 8270	<2.0	2.0	ug/L	CMG	09/09/2009
Phenanthrene	EPA 8270	<2.0	2.0	ug/L	CMG	09/09/2009
Anthracene	EPA 8270	<2.0	2.0	ug/L	CMG	09/09/2009
Fluoranthene	EPA 8270	<2.0	2.0	ug/L	CMG	09/09/2009
Pyrene	EPA 8270	<2.0	2.0	ug/L	CMG	09/09/2009
Benzo [a] Anthracene	EPA 8270	<2.0	2.0	ug/L	CMG	09/09/2009
Chrysene	EPA 8270	<2.0	2.0	ug/L	CMG	09/09/2009
Benzo [b] Fluoranthene	EPA 8270	<2.0	2.0	ug/L	CMG	09/09/2009
Benzo [k] Fluoranthene	EPA 8270	<2.0	2.0	ug/L	CMG	09/09/2009
Benzo [a] Pyrene	EPA 8270	<2.0	2.0	ug/L	CMG	09/09/2009
Indeno [1,2,3-cd] Pyrene	EPA 8270	<2.0	2.0	ug/L	CMG	09/09/2009
Dibenzo [a,h] Anthracene	EPA 8270	<2.0	2.0	ug/L	CMG	09/09/2009
Benzo [g,h,i] Perylene	EPA 8270	<2.0	2.0	ug/L	CMG	09/09/2009
Surrogates:	EPA 8270					
***Nitrobenzene-D5	EPA 8270	40.6	30-130	% R	CMG	09/09/2009
***2-Fluorobiphenyl	EPA 8270	43.0	30-130	% R	CMG	09/09/2009
***P-Terphenyl-D14	EPA 8270	50.6	30-130	% R	CMG	09/09/2009
Extraction	EPA 3510C	1.0		DF	KEF	09/01/2009
TOTAL PETROLEUM HYDROCARBON	Mod. EPA 8100				RJD	09/01/2009
Hydrocarbon Content		760	200	ug/L	RJD	09/01/2009
Surrogate:						
***p-Terphenyl		43.5	40-130	% R	RJD	09/01/2009
Extraction	EPA 3510C	1.0		DF	NOG	08/28/2009
METALS						
Arsenic	EPA 6010B	<0.010	0.010	mg/L	LLZ	08/28/2009
Antimony	EPA 6010B	<0.025	0.025	mg/L	LLZ	08/28/2009
Cadmium	EPA 6010B	<0.0050	0.0050	mg/L	LLZ	08/28/2009
Chromium	EPA 6010B	<0.0050	0.0050	mg/L	LLZ	08/28/2009



ANALYTICAL REPORT

GZA GeoEnvironmental, Inc.
 530 Broadway
 Providence, RI 02909

Meg Kilpatrick

Project Name.: **Former Tidewater Facility**
 Project No.: **03.0043654.00**

Date Received: **08/27/2009**
 Date Reported: **09/10/2009**
 Work Order No.: **0908-00130**

Sample ID: **GH-7 S-3**
 Sample Date: **08/26/2009**

Sample No.: **005**

Test Performed	Method	Results	Reporting Limit	Units	Tech	Analysis Date
Copper	EPA 6010B	0.016	0.015	mg/L	LLZ	08/28/2009
Lead	EPA 6010B	0.023	0.010	mg/L	LLZ	08/28/2009
Nickel	EPA 6010B	<0.010	0.010	mg/L	LLZ	08/28/2009
Selenium	EPA 6010B	<0.025	0.025	mg/L	LLZ	08/28/2009
Silver	EPA 6010B	<0.0050	0.0050	mg/L	LLZ	08/28/2009
Iron	EPA 6010B	1.7	0.025	mg/L	LLZ	08/28/2009
Manganese	EPA 6010B	0.26	0.0050	mg/L	LLZ	08/28/2009
Zinc	EPA 6010B	0.019	0.010	mg/L	LLZ	08/28/2009
Mercury	EPA 7470A	<0.00040	0.00040	mg/L	AJY	08/31/2009
HARDNESS	EPA 200.7	1.6		mg CaCO ₃ /L	LLZ	08/28/2009
Calcium	EPA 200.7	0.41	0.025	mg/L	LLZ	08/28/2009
Magnesium	EPA 200.7	0.14	0.025	mg/L	LLZ	08/28/2009
ANIONS - ION CHROMATOGRAPHY	EPA 300.0				TAJ	08/27/2009
Sulfate	EPA 300.0	<0.60	0.60	mg/L	TAJ	08/27/2009
Ferric Iron	HACH	1.7		mg/L	AJY	09/09/2009
SUBCONTRACTED ANALYTES						
Ferrous Iron	SM-3500-FE D	<0.40	0.40	mg/L	XXX	08/26/2009
Total Suspended Solids	SM-2540D	<2.0	2.0	mg/L	XXX	08/27/2009
Total Cyanide	SM-4500CN-C E	0.06	0.01	mg/L	XXX	09/01/2009
Free Cyanide	SM4500-CN,H	<0.01	0.01	mg/L	XXX	08/28/2009



ANALYTICAL REPORT

GZA GeoEnvironmental, Inc.
 530 Broadway
 Providence, RI 02909

Meg Kilpatrick

Project Name.: **Former Tidewater Facility**
 Project No.: **03.0043654.00**

Date Received: **08/27/2009**
 Date Reported: **09/10/2009**
 Work Order No.: **0908-00130**

Sample ID: **GH-7 S-3 Dissolved Metals**
 Sample Date: **08/26/2009**

Sample No.: **006**

Test Performed	Method	Results	Reporting Limit	Units	Tech	Analysis Date
DISSOLVED METALS						
Arsenic	EPA 6010B	<0.010	0.010	mg/L	LLZ	08/28/2009
Antimony	EPA 6010B	<0.025	0.025	mg/L	LLZ	08/28/2009
Cadmium	EPA 6010B	<0.0050	0.0050	mg/L	LLZ	08/28/2009
Chromium	EPA 6010B	<0.0050	0.0050	mg/L	LLZ	08/28/2009
Copper	EPA 6010B	0.016	0.015	mg/L	LLZ	08/28/2009
Lead	EPA 6010B	<0.010	0.010	mg/L	LLZ	08/28/2009
Nickel	EPA 6010B	<0.010	0.010	mg/L	LLZ	08/28/2009
Selenium	EPA 6010B	<0.025	0.025	mg/L	LLZ	08/28/2009
Silver	EPA 6010B	<0.0050	0.0050	mg/L	LLZ	08/28/2009
Iron	EPA 6010B	0.14	0.025	mg/L	LLZ	08/28/2009
Manganese	EPA 6010B	0.26	0.0050	mg/L	LLZ	08/28/2009
Zinc	EPA 6010B	0.012	0.010	mg/L	LLZ	08/28/2009
Mercury	EPA 7470A	<0.00040	0.00040	mg/L	AJY	08/31/2009



ANALYTICAL REPORT

GZA GeoEnvironmental, Inc.
530 Broadway
Providence, RI 02909

Meg Kilpatrick

Project Name.: **Former Tidewater Facility**
Project No.: **03.0043654.00**

Date Received: **08/27/2009**
Date Reported: **09/10/2009**
Work Order No.: **0908-00130**

Sample ID: **GH-8 S-1**
Sample Date: **08/26/2009**

Sample No.: **007**

Test Performed	Method	Results	Reporting Limit	Units	Tech	Analysis Date
VOLATILE ORGANICS	EPA 8260				MQS	08/31/2009
Dichlorodifluoromethane	EPA 8260	<2.0	2.0	ug/L	MQS	08/31/2009
Chloromethane	EPA 8260	<2.0	2.0	ug/L	MQS	08/31/2009
Vinyl Chloride	EPA 8260	<1.0	1.0	ug/L	MQS	08/31/2009
Bromomethane	EPA 8260	<2.0	2.0	ug/L	MQS	08/31/2009
Chloroethane	EPA 8260	<1.0	1.0	ug/L	MQS	08/31/2009
Trichlorofluoromethane	EPA 8260	<2.0	2.0	ug/L	MQS	08/31/2009
Diethylether	EPA 8260	<5.0	5.0	ug/L	MQS	08/31/2009
Acetone	EPA 8260	<25	25	ug/L	MQS	08/31/2009
1,1-Dichloroethene	EPA 8260	<1.0	1.0	ug/L	MQS	08/31/2009
Dichloromethane	EPA 8260	<2.0	2.0	ug/L	MQS	08/31/2009
Methyl-Tert-Butyl-Ether	EPA 8260	<1.0	1.0	ug/L	MQS	08/31/2009
trans-1,2-Dichloroethene	EPA 8260	<1.0	1.0	ug/L	MQS	08/31/2009
1,1-Dichloroethane	EPA 8260	<1.0	1.0	ug/L	MQS	08/31/2009
2-Butanone	EPA 8260	<25	25	ug/L	MQS	08/31/2009
2,2-Dichloropropane	EPA 8260	<1.0	1.0	ug/L	MQS	08/31/2009
cis-1,2-Dichloroethene	EPA 8260	<1.0	1.0	ug/L	MQS	08/31/2009
Chloroform	EPA 8260	<1.0	1.0	ug/L	MQS	08/31/2009
Bromochloromethane	EPA 8260	<1.0	1.0	ug/L	MQS	08/31/2009
Tetrahydrofuran	EPA 8260	<10	10	ug/L	MQS	08/31/2009
1,1,1-Trichloroethane	EPA 8260	<1.0	1.0	ug/L	MQS	08/31/2009
1,1-Dichloropropene	EPA 8260	<1.0	1.0	ug/L	MQS	08/31/2009
Carbon Tetrachloride	EPA 8260	<1.0	1.0	ug/L	MQS	08/31/2009
1,2-Dichloroethane	EPA 8260	<1.0	1.0	ug/L	MQS	08/31/2009
Benzene	EPA 8260	<1.0	1.0	ug/L	MQS	08/31/2009
Trichloroethene	EPA 8260	<1.0	1.0	ug/L	MQS	08/31/2009
1,2-Dichloropropane	EPA 8260	<1.0	1.0	ug/L	MQS	08/31/2009
Bromodichloromethane	EPA 8260	<1.0	1.0	ug/L	MQS	08/31/2009
Dibromomethane	EPA 8260	<1.0	1.0	ug/L	MQS	08/31/2009
4-Methyl-2-Pentanone	EPA 8260	<25	25	ug/L	MQS	08/31/2009
cis-1,3-Dichloropropene	EPA 8260	<1.0	1.0	ug/L	MQS	08/31/2009
Toluene	EPA 8260	<1.0	1.0	ug/L	MQS	08/31/2009
trans-1,3-Dichloropropene	EPA 8260	<2.0	2.0	ug/L	MQS	08/31/2009
1,1,2-Trichloroethane	EPA 8260	<1.0	1.0	ug/L	MQS	08/31/2009
2-Hexanone	EPA 8260	<25	25	ug/L	MQS	08/31/2009



ANALYTICAL REPORT

GZA GeoEnvironmental, Inc.
 530 Broadway
 Providence, RI 02909

Meg Kilpatrick

Project Name.: **Former Tidewater Facility**
 Project No.: **03.0043654.00**

Date Received: **08/27/2009**
 Date Reported: **09/10/2009**
 Work Order No.: **0908-00130**

Sample ID: **GH-8 S-1**
 Sample Date: **08/26/2009**

Sample No.: **007**

Test Performed	Method	Results	Reporting Limit	Units	Tech	Analysis Date
1,3-Dichloropropane	EPA 8260	<1.0	1.0	ug/L	MQS	08/31/2009
Tetrachloroethene	EPA 8260	<1.0	1.0	ug/L	MQS	08/31/2009
Dibromochloromethane	EPA 8260	<1.0	1.0	ug/L	MQS	08/31/2009
1,2-Dibromoethane (EDB)	EPA 8260	<2.0	2.0	ug/L	MQS	08/31/2009
Chlorobenzene	EPA 8260	<1.0	1.0	ug/L	MQS	08/31/2009
1,1,1,2-Tetrachloroethane	EPA 8260	<1.0	1.0	ug/L	MQS	08/31/2009
Ethylbenzene	EPA 8260	<1.0	1.0	ug/L	MQS	08/31/2009
m&p-Xylene	EPA 8260	<2.0	2.0	ug/L	MQS	08/31/2009
o-Xylene	EPA 8260	<1.0	1.0	ug/L	MQS	08/31/2009
Styrene	EPA 8260	<1.0	1.0	ug/L	MQS	08/31/2009
Bromoform	EPA 8260	<2.0	2.0	ug/L	MQS	08/31/2009
Isopropylbenzene	EPA 8260	<1.0	1.0	ug/L	MQS	08/31/2009
1,1,2,2-Tetrachloroethane	EPA 8260	<1.0	1.0	ug/L	MQS	08/31/2009
1,2,3-Trichloropropane	EPA 8260	<1.0	1.0	ug/L	MQS	08/31/2009
Bromobenzene	EPA 8260	<1.0	1.0	ug/L	MQS	08/31/2009
N-Propylbenzene	EPA 8260	<1.0	1.0	ug/L	MQS	08/31/2009
2-Chlorotoluene	EPA 8260	<1.0	1.0	ug/L	MQS	08/31/2009
1,3,5-Trimethylbenzene	EPA 8260	<1.0	1.0	ug/L	MQS	08/31/2009
4-Chlorotoluene	EPA 8260	<1.0	1.0	ug/L	MQS	08/31/2009
tert-Butylbenzene	EPA 8260	<1.0	1.0	ug/L	MQS	08/31/2009
1,2,4-Trimethylbenzene	EPA 8260	<1.0	1.0	ug/L	MQS	08/31/2009
sec-Butylbenzene	EPA 8260	<1.0	1.0	ug/L	MQS	08/31/2009
p-Isopropyltoluene	EPA 8260	<1.0	1.0	ug/L	MQS	08/31/2009
1,3-Dichlorobenzene	EPA 8260	<1.0	1.0	ug/L	MQS	08/31/2009
1,4-Dichlorobenzene	EPA 8260	<1.0	1.0	ug/L	MQS	08/31/2009
n-Butylbenzene	EPA 8260	<1.0	1.0	ug/L	MQS	08/31/2009
1,2-Dichlorobenzene	EPA 8260	<1.0	1.0	ug/L	MQS	08/31/2009
1,2-Dibromo-3-Chloropropane	EPA 8260	<5.0	5.0	ug/L	MQS	08/31/2009
1,2,4-Trichlorobenzene	EPA 8260	<1.0	1.0	ug/L	MQS	08/31/2009
Hexachlorobutadiene	EPA 8260	<1.0	1.0	ug/L	MQS	08/31/2009
Naphthalene	EPA 8260	<2.0	2.0	ug/L	MQS	08/31/2009
1,2,3-Trichlorobenzene	EPA 8260	<1.0	1.0	ug/L	MQS	08/31/2009
Surrogates:	EPA 8260					
***1,2-Dichloroethane-D4	EPA 8260	102	70-130	% R	MQS	08/31/2009
***Toluene-D8	EPA 8260	101	70-130	% R	MQS	08/31/2009



ANALYTICAL REPORT

GZA GeoEnvironmental, Inc.
 530 Broadway
 Providence, RI 02909

Meg Kilpatrick

Project Name.: **Former Tidewater Facility**
 Project No.: **03.0043654.00**

Date Received: **08/27/2009**
 Date Reported: **09/10/2009**
 Work Order No.: **0908-00130**

Sample ID: **GH-8 S-1**
 Sample Date: **08/26/2009**

Sample No.: **007**

Test Performed	Method	Results	Reporting Limit	Units	Tech	Analysis Date
***4-Bromofluorobenzene	EPA 8260	101	70-130	% R	MQS	08/31/2009
Preparation	EPA 5030B	1.0		CF	MQS	08/31/2009
PAHS BY GCMS	EPA 8270				CMG	09/09/2009
Naphthalene	EPA 8270	<2.0	2.0	ug/L	CMG	09/09/2009
2-Methylnaphthalene	EPA 8270	<2.0	2.0	ug/L	CMG	09/09/2009
Acenaphthylene	EPA 8270	<2.0	2.0	ug/L	CMG	09/09/2009
Acenaphthene	EPA 8270	<2.0	2.0	ug/L	CMG	09/09/2009
Fluorene	EPA 8270	<2.0	2.0	ug/L	CMG	09/09/2009
Phenanthrene	EPA 8270	<2.0	2.0	ug/L	CMG	09/09/2009
Anthracene	EPA 8270	<2.0	2.0	ug/L	CMG	09/09/2009
Fluoranthene	EPA 8270	<2.0	2.0	ug/L	CMG	09/09/2009
Pyrene	EPA 8270	<2.0	2.0	ug/L	CMG	09/09/2009
Benzo [a] Anthracene	EPA 8270	<2.0	2.0	ug/L	CMG	09/09/2009
Chrysene	EPA 8270	<2.0	2.0	ug/L	CMG	09/09/2009
Benzo [b] Fluoranthene	EPA 8270	<2.0	2.0	ug/L	CMG	09/09/2009
Benzo [k] Fluoranthene	EPA 8270	<2.0	2.0	ug/L	CMG	09/09/2009
Benzo [a] Pyrene	EPA 8270	<2.0	2.0	ug/L	CMG	09/09/2009
Indeno [1,2,3-cd] Pyrene	EPA 8270	<2.0	2.0	ug/L	CMG	09/09/2009
Dibenzo [a,h] Anthracene	EPA 8270	<2.0	2.0	ug/L	CMG	09/09/2009
Benzo [g,h,i] Perylene	EPA 8270	<2.0	2.0	ug/L	CMG	09/09/2009
Surrogates:	EPA 8270					
***Nitrobenzene-D5	EPA 8270	52.8	30-130	% R	CMG	09/09/2009
***2-Fluorobiphenyl	EPA 8270	55.0	30-130	% R	CMG	09/09/2009
***P-Terphenyl-D14	EPA 8270	62.4	30-130	% R	CMG	09/09/2009
Extraction	EPA 3510C	1.0		DF	KEF	09/01/2009
TOTAL PETROLEUM HYDROCARBON	Mod. EPA 8100				RJD	09/01/2009
Hydrocarbon Content		280	200	ug/L	RJD	09/01/2009
Surrogate:						
***p-Terphenyl		55.0	40-130	% R	RJD	09/01/2009
Extraction	EPA 3510C	1.0		DF	NOG	08/28/2009
METALS						
Arsenic	EPA 6010B	<0.010	0.010	mg/L	LLZ	08/28/2009
Antimony	EPA 6010B	<0.025	0.025	mg/L	LLZ	08/28/2009
Cadmium	EPA 6010B	<0.0050	0.0050	mg/L	LLZ	08/28/2009
Chromium	EPA 6010B	<0.0050	0.0050	mg/L	LLZ	08/28/2009



ANALYTICAL REPORT

GZA GeoEnvironmental, Inc.
 530 Broadway
 Providence, RI 02909

Meg Kilpatrick

Project Name.: **Former Tidewater Facility**
 Project No.: **03.0043654.00**

Date Received: **08/27/2009**
 Date Reported: **09/10/2009**
 Work Order No.: **0908-00130**

Sample ID: **GH-8 S-1**
 Sample Date: **08/26/2009**

Sample No.: **007**

Test Performed	Method	Results	Reporting Limit	Units	Tech	Analysis Date
Copper	EPA 6010B	0.016	0.015	mg/L	LLZ	08/28/2009
Lead	EPA 6010B	0.028	0.010	mg/L	LLZ	08/28/2009
Nickel	EPA 6010B	<0.010	0.010	mg/L	LLZ	08/28/2009
Selenium	EPA 6010B	<0.025	0.025	mg/L	LLZ	08/28/2009
Silver	EPA 6010B	<0.0050	0.0050	mg/L	LLZ	08/28/2009
Iron	EPA 6010B	0.27	0.025	mg/L	LLZ	08/28/2009
Manganese	EPA 6010B	0.17	0.0050	mg/L	LLZ	08/28/2009
Zinc	EPA 6010B	0.026	0.010	mg/L	LLZ	08/28/2009
Mercury	EPA 7470A	<0.00040	0.00040	mg/L	AJY	08/31/2009
HARDNESS	EPA 200.7	1.3		mg CaCO ₃ /L	LLZ	08/28/2009
Calcium	EPA 200.7	0.31	0.025	mg/L	LLZ	08/28/2009
Magnesium	EPA 200.7	0.12	0.025	mg/L	LLZ	08/28/2009
ANIONS - ION CHROMATOGRAPHY	EPA 300.0				TAJ	08/27/2009
Sulfate	EPA 300.0	0.90	0.60	mg/L	TAJ	08/27/2009
Ferric Iron	HACH	0.27		mg/L	AJY	09/09/2009
SUBCONTRACTED ANALYTES						
Ferrous Iron	SM-3500-FE D	<0.40	0.40	mg/L	XXX	08/26/2009
Total Suspended Solids	SM-2540D	<2.0	2.0	mg/L	XXX	08/27/2009
Total Cyanide	SM-4500CN-C E	<0.01	0.01	mg/L	XXX	09/01/2009
Free Cyanide	SM4500-CN,H	<0.01	0.01	mg/L	XXX	08/28/2009



ANALYTICAL REPORT

GZA GeoEnvironmental, Inc.
 530 Broadway
 Providence, RI 02909

Meg Kilpatrick

Project Name.: **Former Tidewater Facility**
 Project No.: **03.0043654.00**

Date Received: **08/27/2009**
 Date Reported: **09/10/2009**
 Work Order No.: **0908-00130**

Sample ID: **GH-8 S-1 Dissolved Metals**
 Sample Date: **08/26/2009**

Sample No.: **008**

Test Performed	Method	Results	Reporting Limit	Units	Tech	Analysis Date
DISSOLVED METALS						
Arsenic	EPA 6010B	<0.010	0.010	mg/L	LLZ	08/28/2009
Antimony	EPA 6010B	<0.025	0.025	mg/L	LLZ	08/28/2009
Cadmium	EPA 6010B	<0.0050	0.0050	mg/L	LLZ	08/28/2009
Chromium	EPA 6010B	<0.0050	0.0050	mg/L	LLZ	08/28/2009
Copper	EPA 6010B	0.016	0.015	mg/L	LLZ	08/28/2009
Lead	EPA 6010B	0.024	0.010	mg/L	LLZ	08/28/2009
Nickel	EPA 6010B	<0.010	0.010	mg/L	LLZ	08/28/2009
Selenium	EPA 6010B	<0.025	0.025	mg/L	LLZ	08/28/2009
Silver	EPA 6010B	<0.0050	0.0050	mg/L	LLZ	08/28/2009
Iron	EPA 6010B	0.045	0.025	mg/L	LLZ	08/28/2009
Manganese	EPA 6010B	0.17	0.0050	mg/L	LLZ	08/28/2009
Zinc	EPA 6010B	0.031	0.010	mg/L	LLZ	08/28/2009
Mercury	EPA 7470A	<0.00040	0.00040	mg/L	AJY	08/31/2009



ANALYTICAL REPORT

GZA GeoEnvironmental, Inc.
 530 Broadway
 Providence, RI 02909

Meg Kilpatrick

Project Name.: **Former Tidewater Facility**
 Project No.: **03.0043654.00**

Date Received: **08/27/2009**
 Date Reported: **09/10/2009**
 Work Order No.: **0908-00130**

Sample ID: **GH-8 S-2**
 Sample Date: **08/26/2009**

Sample No.: **009**

Test Performed	Method	Results	Reporting Limit	Units	Tech	Analysis Date
VOLATILE ORGANICS	EPA 8260				MQS	08/31/2009
Dichlorodifluoromethane	EPA 8260	<2.0	2.0	ug/L	MQS	08/31/2009
Chloromethane	EPA 8260	<2.0	2.0	ug/L	MQS	08/31/2009
Vinyl Chloride	EPA 8260	<1.0	1.0	ug/L	MQS	08/31/2009
Bromomethane	EPA 8260	<2.0	2.0	ug/L	MQS	08/31/2009
Chloroethane	EPA 8260	<1.0	1.0	ug/L	MQS	08/31/2009
Trichlorofluoromethane	EPA 8260	<2.0	2.0	ug/L	MQS	08/31/2009
Diethylether	EPA 8260	<5.0	5.0	ug/L	MQS	08/31/2009
Acetone	EPA 8260	<25	25	ug/L	MQS	08/31/2009
1,1-Dichloroethene	EPA 8260	<1.0	1.0	ug/L	MQS	08/31/2009
Dichloromethane	EPA 8260	<2.0	2.0	ug/L	MQS	08/31/2009
Methyl-Tert-Butyl-Ether	EPA 8260	<1.0	1.0	ug/L	MQS	08/31/2009
trans-1,2-Dichloroethene	EPA 8260	<1.0	1.0	ug/L	MQS	08/31/2009
1,1-Dichloroethane	EPA 8260	<1.0	1.0	ug/L	MQS	08/31/2009
2-Butanone	EPA 8260	<25	25	ug/L	MQS	08/31/2009
2,2-Dichloropropane	EPA 8260	<1.0	1.0	ug/L	MQS	08/31/2009
cis-1,2-Dichloroethene	EPA 8260	<1.0	1.0	ug/L	MQS	08/31/2009
Chloroform	EPA 8260	<1.0	1.0	ug/L	MQS	08/31/2009
Bromochloromethane	EPA 8260	<1.0	1.0	ug/L	MQS	08/31/2009
Tetrahydrofuran	EPA 8260	<10	10	ug/L	MQS	08/31/2009
1,1,1-Trichloroethane	EPA 8260	<1.0	1.0	ug/L	MQS	08/31/2009
1,1-Dichloropropene	EPA 8260	<1.0	1.0	ug/L	MQS	08/31/2009
Carbon Tetrachloride	EPA 8260	<1.0	1.0	ug/L	MQS	08/31/2009
1,2-Dichloroethane	EPA 8260	<1.0	1.0	ug/L	MQS	08/31/2009
Benzene	EPA 8260	<1.0	1.0	ug/L	MQS	08/31/2009
Trichloroethene	EPA 8260	<1.0	1.0	ug/L	MQS	08/31/2009
1,2-Dichloropropane	EPA 8260	<1.0	1.0	ug/L	MQS	08/31/2009
Bromodichloromethane	EPA 8260	<1.0	1.0	ug/L	MQS	08/31/2009
Dibromomethane	EPA 8260	<1.0	1.0	ug/L	MQS	08/31/2009
4-Methyl-2-Pentanone	EPA 8260	<25	25	ug/L	MQS	08/31/2009
cis-1,3-Dichloropropene	EPA 8260	<1.0	1.0	ug/L	MQS	08/31/2009
Toluene	EPA 8260	<1.0	1.0	ug/L	MQS	08/31/2009
trans-1,3-Dichloropropene	EPA 8260	<2.0	2.0	ug/L	MQS	08/31/2009
1,1,2-Trichloroethane	EPA 8260	<1.0	1.0	ug/L	MQS	08/31/2009
2-Hexanone	EPA 8260	<25	25	ug/L	MQS	08/31/2009



ANALYTICAL REPORT

GZA GeoEnvironmental, Inc.
 530 Broadway
 Providence, RI 02909

Meg Kilpatrick

Project Name.: **Former Tidewater Facility**
 Project No.: **03.0043654.00**

Date Received: **08/27/2009**
 Date Reported: **09/10/2009**
 Work Order No.: **0908-00130**

Sample ID: **GH-8 S-2**
 Sample Date: **08/26/2009**

Sample No.: **009**

Test Performed	Method	Results	Reporting Limit	Units	Tech	Analysis Date
1,3-Dichloropropane	EPA 8260	<1.0	1.0	ug/L	MQS	08/31/2009
Tetrachloroethene	EPA 8260	<1.0	1.0	ug/L	MQS	08/31/2009
Dibromochloromethane	EPA 8260	<1.0	1.0	ug/L	MQS	08/31/2009
1,2-Dibromoethane (EDB)	EPA 8260	<2.0	2.0	ug/L	MQS	08/31/2009
Chlorobenzene	EPA 8260	<1.0	1.0	ug/L	MQS	08/31/2009
1,1,1,2-Tetrachloroethane	EPA 8260	<1.0	1.0	ug/L	MQS	08/31/2009
Ethylbenzene	EPA 8260	<1.0	1.0	ug/L	MQS	08/31/2009
m&p-Xylene	EPA 8260	<2.0	2.0	ug/L	MQS	08/31/2009
o-Xylene	EPA 8260	<1.0	1.0	ug/L	MQS	08/31/2009
Styrene	EPA 8260	<1.0	1.0	ug/L	MQS	08/31/2009
Bromoform	EPA 8260	<2.0	2.0	ug/L	MQS	08/31/2009
Isopropylbenzene	EPA 8260	<1.0	1.0	ug/L	MQS	08/31/2009
1,1,2,2-Tetrachloroethane	EPA 8260	<1.0	1.0	ug/L	MQS	08/31/2009
1,2,3-Trichloropropane	EPA 8260	<1.0	1.0	ug/L	MQS	08/31/2009
Bromobenzene	EPA 8260	<1.0	1.0	ug/L	MQS	08/31/2009
N-Propylbenzene	EPA 8260	<1.0	1.0	ug/L	MQS	08/31/2009
2-Chlorotoluene	EPA 8260	<1.0	1.0	ug/L	MQS	08/31/2009
1,3,5-Trimethylbenzene	EPA 8260	<1.0	1.0	ug/L	MQS	08/31/2009
4-Chlorotoluene	EPA 8260	<1.0	1.0	ug/L	MQS	08/31/2009
tert-Butylbenzene	EPA 8260	<1.0	1.0	ug/L	MQS	08/31/2009
1,2,4-Trimethylbenzene	EPA 8260	<1.0	1.0	ug/L	MQS	08/31/2009
sec-Butylbenzene	EPA 8260	<1.0	1.0	ug/L	MQS	08/31/2009
p-Isopropyltoluene	EPA 8260	<1.0	1.0	ug/L	MQS	08/31/2009
1,3-Dichlorobenzene	EPA 8260	<1.0	1.0	ug/L	MQS	08/31/2009
1,4-Dichlorobenzene	EPA 8260	<1.0	1.0	ug/L	MQS	08/31/2009
n-Butylbenzene	EPA 8260	<1.0	1.0	ug/L	MQS	08/31/2009
1,2-Dichlorobenzene	EPA 8260	<1.0	1.0	ug/L	MQS	08/31/2009
1,2-Dibromo-3-Chloropropane	EPA 8260	<5.0	5.0	ug/L	MQS	08/31/2009
1,2,4-Trichlorobenzene	EPA 8260	<1.0	1.0	ug/L	MQS	08/31/2009
Hexachlorobutadiene	EPA 8260	<1.0	1.0	ug/L	MQS	08/31/2009
Naphthalene	EPA 8260	<2.0	2.0	ug/L	MQS	08/31/2009
1,2,3-Trichlorobenzene	EPA 8260	<1.0	1.0	ug/L	MQS	08/31/2009
Surrogates:	EPA 8260					
***1,2-Dichloroethane-D4	EPA 8260	98.3	70-130	% R	MQS	08/31/2009
***Toluene-D8	EPA 8260	100	70-130	% R	MQS	08/31/2009



ANALYTICAL REPORT

GZA GeoEnvironmental, Inc.
 530 Broadway
 Providence, RI 02909

Meg Kilpatrick

Project Name.: **Former Tidewater Facility**
 Project No.: **03.0043654.00**

Date Received: **08/27/2009**
 Date Reported: **09/10/2009**
 Work Order No.: **0908-00130**

Sample ID: **GH-8 S-2**
 Sample Date: **08/26/2009**

Sample No.: **009**

Test Performed	Method	Results	Reporting Limit	Units	Tech	Analysis Date
***4-Bromofluorobenzene	EPA 8260	100	70-130	% R	MQS	08/31/2009
Preparation	EPA 5030B	1.0		CF	MQS	08/31/2009
PAHS BY GCMS	EPA 8270				CMG	09/09/2009
Naphthalene	EPA 8270	<2.0	2.0	ug/L	CMG	09/09/2009
2-Methylnaphthalene	EPA 8270	<2.0	2.0	ug/L	CMG	09/09/2009
Acenaphthylene	EPA 8270	<2.0	2.0	ug/L	CMG	09/09/2009
Acenaphthene	EPA 8270	<2.0	2.0	ug/L	CMG	09/09/2009
Fluorene	EPA 8270	<2.0	2.0	ug/L	CMG	09/09/2009
Phenanthrene	EPA 8270	<2.0	2.0	ug/L	CMG	09/09/2009
Anthracene	EPA 8270	<2.0	2.0	ug/L	CMG	09/09/2009
Fluoranthene	EPA 8270	<2.0	2.0	ug/L	CMG	09/09/2009
Pyrene	EPA 8270	<2.0	2.0	ug/L	CMG	09/09/2009
Benzo [a] Anthracene	EPA 8270	<2.0	2.0	ug/L	CMG	09/09/2009
Chrysene	EPA 8270	<2.0	2.0	ug/L	CMG	09/09/2009
Benzo [b] Fluoranthene	EPA 8270	<2.0	2.0	ug/L	CMG	09/09/2009
Benzo [k] Fluoranthene	EPA 8270	<2.0	2.0	ug/L	CMG	09/09/2009
Benzo [a] Pyrene	EPA 8270	<2.0	2.0	ug/L	CMG	09/09/2009
Indeno [1,2,3-cd] Pyrene	EPA 8270	<2.0	2.0	ug/L	CMG	09/09/2009
Dibenzo [a,h] Anthracene	EPA 8270	<2.0	2.0	ug/L	CMG	09/09/2009
Benzo [g,h,i] Perylene	EPA 8270	<2.0	2.0	ug/L	CMG	09/09/2009
Surrogates:	EPA 8270					
***Nitrobenzene-D5	EPA 8270	49.9	30-130	% R	CMG	09/09/2009
***2-Fluorobiphenyl	EPA 8270	52.4	30-130	% R	CMG	09/09/2009
***P-Terphenyl-D14	EPA 8270	61.1	30-130	% R	CMG	09/09/2009
Extraction	EPA 3510C	1.0		DF	KEF	09/01/2009
TOTAL PETROLEUM HYDROCARBON	Mod. EPA 8100				RJD	09/01/2009
Hydrocarbon Content		340	200	ug/L	RJD	09/01/2009
Surrogate:						
***p-Terphenyl		76.1	40-130	% R	RJD	09/01/2009
Extraction	EPA 3510C	1.0		DF	NOG	08/28/2009
METALS						
Arsenic	EPA 6010B	<0.010	0.010	mg/L	LLZ	08/28/2009
Antimony	EPA 6010B	<0.025	0.025	mg/L	LLZ	08/28/2009
Cadmium	EPA 6010B	<0.0050	0.0050	mg/L	LLZ	08/28/2009
Chromium	EPA 6010B	<0.0050	0.0050	mg/L	LLZ	08/28/2009



ANALYTICAL REPORT

GZA GeoEnvironmental, Inc.
 530 Broadway
 Providence, RI 02909

Meg Kilpatrick

Project Name.: **Former Tidewater Facility**
 Project No.: **03.0043654.00**

Date Received: **08/27/2009**
 Date Reported: **09/10/2009**
 Work Order No.: **0908-00130**

Sample ID: **GH-8 S-2**
 Sample Date: **08/26/2009**

Sample No.: **009**

Test Performed	Method	Results	Reporting Limit	Units	Tech	Analysis Date
Copper	EPA 6010B	0.015	0.015	mg/L	LLZ	08/28/2009
Lead	EPA 6010B	0.029	0.010	mg/L	LLZ	08/28/2009
Nickel	EPA 6010B	<0.010	0.010	mg/L	LLZ	08/28/2009
Selenium	EPA 6010B	<0.025	0.025	mg/L	LLZ	08/28/2009
Silver	EPA 6010B	<0.0050	0.0050	mg/L	LLZ	08/28/2009
Iron	EPA 6010B	0.27	0.025	mg/L	LLZ	08/28/2009
Manganese	EPA 6010B	0.17	0.0050	mg/L	LLZ	08/28/2009
Zinc	EPA 6010B	0.026	0.010	mg/L	LLZ	08/28/2009
Mercury	EPA 7470A	<0.00040	0.00040	mg/L	AJY	08/31/2009
HARDNESS	EPA 200.7	1.2		mg CaCO ₃ /L	LLZ	08/28/2009
Calcium	EPA 200.7	0.29	0.025	mg/L	LLZ	08/28/2009
Magnesium	EPA 200.7	0.12	0.025	mg/L	LLZ	08/28/2009
ANIONS - ION CHROMATOGRAPHY	EPA 300.0				TAJ	08/27/2009
Sulfate	EPA 300.0	0.89	0.60	mg/L	TAJ	08/27/2009
Ferric Iron	HACH	0.27		mg/L	AJY	09/09/2009
SUBCONTRACTED ANALYTES						
Ferrous Iron	SM-3500-FE D	<0.40	0.40	mg/L	XXX	08/26/2009
Total Suspended Solids	SM-2540D	<2.0	2.0	mg/L	XXX	08/27/2009
Total Cyanide	SM-4500CN-C E	0.04	0.04	mg/L	XXX	09/01/2009
Free Cyanide	SM4500-CN,H	<0.01	0.01	mg/L	XXX	08/28/2009



ANALYTICAL REPORT

GZA GeoEnvironmental, Inc.
 530 Broadway
 Providence, RI 02909

Meg Kilpatrick

Project Name.: **Former Tidewater Facility**
 Project No.: **03.0043654.00**

Date Received: **08/27/2009**
 Date Reported: **09/10/2009**
 Work Order No.: **0908-00130**

Sample ID: **GH-8 S-2 Dissolved Metals**

Sample No.: **010**

Sample Date: **08/26/2009**

Test Performed	Method	Results	Reporting Limit	Units	Tech	Analysis Date
DISSOLVED METALS						
Arsenic	EPA 6010B	<0.010	0.010	mg/L	LLZ	08/28/2009
Antimony	EPA 6010B	<0.025	0.025	mg/L	LLZ	08/28/2009
Cadmium	EPA 6010B	<0.0050	0.0050	mg/L	LLZ	08/28/2009
Chromium	EPA 6010B	<0.0050	0.0050	mg/L	LLZ	08/28/2009
Copper	EPA 6010B	0.015	0.015	mg/L	LLZ	08/28/2009
Lead	EPA 6010B	0.026	0.010	mg/L	LLZ	08/28/2009
Nickel	EPA 6010B	<0.010	0.010	mg/L	LLZ	08/28/2009
Selenium	EPA 6010B	<0.025	0.025	mg/L	LLZ	08/28/2009
Silver	EPA 6010B	<0.0050	0.0050	mg/L	LLZ	08/28/2009
Iron	EPA 6010B	0.071	0.025	mg/L	LLZ	08/28/2009
Manganese	EPA 6010B	0.17	0.0050	mg/L	LLZ	08/28/2009
Zinc	EPA 6010B	0.031	0.010	mg/L	LLZ	08/28/2009
Mercury	EPA 7470A	<0.00040	0.00040	mg/L	AJY	08/31/2009



ANALYTICAL REPORT

GZA GeoEnvironmental, Inc.
 530 Broadway
 Providence, RI 02909

Meg Kilpatrick

Project Name.: **Former Tidewater Facility**
 Project No.: **03.0043654.00**

Date Received: **08/27/2009**
 Date Reported: **09/10/2009**
 Work Order No.: **0908-00130**

Sample ID: **GH-8 S-3**
 Sample Date: **08/26/2009**

Sample No.: **011**

Test Performed	Method	Results	Reporting Limit	Units	Tech	Analysis Date
VOLATILE ORGANICS	EPA 8260				MQS	08/31/2009
Dichlorodifluoromethane	EPA 8260	<2.0	2.0	ug/L	MQS	08/31/2009
Chloromethane	EPA 8260	<2.0	2.0	ug/L	MQS	08/31/2009
Vinyl Chloride	EPA 8260	<1.0	1.0	ug/L	MQS	08/31/2009
Bromomethane	EPA 8260	<2.0	2.0	ug/L	MQS	08/31/2009
Chloroethane	EPA 8260	<1.0	1.0	ug/L	MQS	08/31/2009
Trichlorofluoromethane	EPA 8260	<2.0	2.0	ug/L	MQS	08/31/2009
Diethylether	EPA 8260	<5.0	5.0	ug/L	MQS	08/31/2009
Acetone	EPA 8260	<25	25	ug/L	MQS	08/31/2009
1,1-Dichloroethene	EPA 8260	<1.0	1.0	ug/L	MQS	08/31/2009
Dichloromethane	EPA 8260	<2.0	2.0	ug/L	MQS	08/31/2009
Methyl-Tert-Butyl-Ether	EPA 8260	<1.0	1.0	ug/L	MQS	08/31/2009
trans-1,2-Dichloroethene	EPA 8260	<1.0	1.0	ug/L	MQS	08/31/2009
1,1-Dichloroethane	EPA 8260	<1.0	1.0	ug/L	MQS	08/31/2009
2-Butanone	EPA 8260	<25	25	ug/L	MQS	08/31/2009
2,2-Dichloropropane	EPA 8260	<1.0	1.0	ug/L	MQS	08/31/2009
cis-1,2-Dichloroethene	EPA 8260	<1.0	1.0	ug/L	MQS	08/31/2009
Chloroform	EPA 8260	<1.0	1.0	ug/L	MQS	08/31/2009
Bromochloromethane	EPA 8260	<1.0	1.0	ug/L	MQS	08/31/2009
Tetrahydrofuran	EPA 8260	<10	10	ug/L	MQS	08/31/2009
1,1,1-Trichloroethane	EPA 8260	<1.0	1.0	ug/L	MQS	08/31/2009
1,1-Dichloropropene	EPA 8260	<1.0	1.0	ug/L	MQS	08/31/2009
Carbon Tetrachloride	EPA 8260	<1.0	1.0	ug/L	MQS	08/31/2009
1,2-Dichloroethane	EPA 8260	<1.0	1.0	ug/L	MQS	08/31/2009
Benzene	EPA 8260	<1.0	1.0	ug/L	MQS	08/31/2009
Trichloroethene	EPA 8260	<1.0	1.0	ug/L	MQS	08/31/2009
1,2-Dichloropropane	EPA 8260	<1.0	1.0	ug/L	MQS	08/31/2009
Bromodichloromethane	EPA 8260	<1.0	1.0	ug/L	MQS	08/31/2009
Dibromomethane	EPA 8260	<1.0	1.0	ug/L	MQS	08/31/2009
4-Methyl-2-Pentanone	EPA 8260	<25	25	ug/L	MQS	08/31/2009
cis-1,3-Dichloropropene	EPA 8260	<1.0	1.0	ug/L	MQS	08/31/2009
Toluene	EPA 8260	<1.0	1.0	ug/L	MQS	08/31/2009
trans-1,3-Dichloropropene	EPA 8260	<2.0	2.0	ug/L	MQS	08/31/2009
1,1,2-Trichloroethane	EPA 8260	<1.0	1.0	ug/L	MQS	08/31/2009
2-Hexanone	EPA 8260	<25	25	ug/L	MQS	08/31/2009



ANALYTICAL REPORT

GZA GeoEnvironmental, Inc.
 530 Broadway
 Providence, RI 02909

Meg Kilpatrick

Project Name.: **Former Tidewater Facility**
 Project No.: **03.0043654.00**

Date Received: **08/27/2009**
 Date Reported: **09/10/2009**
 Work Order No.: **0908-00130**

Sample ID: **GH-8 S-3**
 Sample Date: **08/26/2009**

Sample No.: **011**

Test Performed	Method	Results	Reporting Limit	Units	Tech	Analysis Date
1,3-Dichloropropane	EPA 8260	<1.0	1.0	ug/L	MQS	08/31/2009
Tetrachloroethene	EPA 8260	<1.0	1.0	ug/L	MQS	08/31/2009
Dibromochloromethane	EPA 8260	<1.0	1.0	ug/L	MQS	08/31/2009
1,2-Dibromoethane (EDB)	EPA 8260	<2.0	2.0	ug/L	MQS	08/31/2009
Chlorobenzene	EPA 8260	<1.0	1.0	ug/L	MQS	08/31/2009
1,1,1,2-Tetrachloroethane	EPA 8260	<1.0	1.0	ug/L	MQS	08/31/2009
Ethylbenzene	EPA 8260	<1.0	1.0	ug/L	MQS	08/31/2009
m&p-Xylene	EPA 8260	<2.0	2.0	ug/L	MQS	08/31/2009
o-Xylene	EPA 8260	<1.0	1.0	ug/L	MQS	08/31/2009
Styrene	EPA 8260	<1.0	1.0	ug/L	MQS	08/31/2009
Bromoform	EPA 8260	<2.0	2.0	ug/L	MQS	08/31/2009
Isopropylbenzene	EPA 8260	<1.0	1.0	ug/L	MQS	08/31/2009
1,1,2,2-Tetrachloroethane	EPA 8260	<1.0	1.0	ug/L	MQS	08/31/2009
1,2,3-Trichloropropane	EPA 8260	<1.0	1.0	ug/L	MQS	08/31/2009
Bromobenzene	EPA 8260	<1.0	1.0	ug/L	MQS	08/31/2009
N-Propylbenzene	EPA 8260	<1.0	1.0	ug/L	MQS	08/31/2009
2-Chlorotoluene	EPA 8260	<1.0	1.0	ug/L	MQS	08/31/2009
1,3,5-Trimethylbenzene	EPA 8260	<1.0	1.0	ug/L	MQS	08/31/2009
4-Chlorotoluene	EPA 8260	<1.0	1.0	ug/L	MQS	08/31/2009
tert-Butylbenzene	EPA 8260	<1.0	1.0	ug/L	MQS	08/31/2009
1,2,4-Trimethylbenzene	EPA 8260	<1.0	1.0	ug/L	MQS	08/31/2009
sec-Butylbenzene	EPA 8260	<1.0	1.0	ug/L	MQS	08/31/2009
p-Isopropyltoluene	EPA 8260	<1.0	1.0	ug/L	MQS	08/31/2009
1,3-Dichlorobenzene	EPA 8260	<1.0	1.0	ug/L	MQS	08/31/2009
1,4-Dichlorobenzene	EPA 8260	<1.0	1.0	ug/L	MQS	08/31/2009
n-Butylbenzene	EPA 8260	<1.0	1.0	ug/L	MQS	08/31/2009
1,2-Dichlorobenzene	EPA 8260	<1.0	1.0	ug/L	MQS	08/31/2009
1,2-Dibromo-3-Chloropropane	EPA 8260	<5.0	5.0	ug/L	MQS	08/31/2009
1,2,4-Trichlorobenzene	EPA 8260	<1.0	1.0	ug/L	MQS	08/31/2009
Hexachlorobutadiene	EPA 8260	<1.0	1.0	ug/L	MQS	08/31/2009
Naphthalene	EPA 8260	<2.0	2.0	ug/L	MQS	08/31/2009
1,2,3-Trichlorobenzene	EPA 8260	<1.0	1.0	ug/L	MQS	08/31/2009
Surrogates:	EPA 8260					
***1,2-Dichloroethane-D4	EPA 8260	95.9	70-130	% R	MQS	08/31/2009
***Toluene-D8	EPA 8260	98.7	70-130	% R	MQS	08/31/2009



ANALYTICAL REPORT

GZA GeoEnvironmental, Inc.
 530 Broadway
 Providence, RI 02909

Meg Kilpatrick

Project Name.: **Former Tidewater Facility**
 Project No.: **03.0043654.00**

Date Received: **08/27/2009**
 Date Reported: **09/10/2009**
 Work Order No.: **0908-00130**

Sample ID: **GH-8 S-3**
 Sample Date: **08/26/2009**

Sample No.: **011**

Test Performed	Method	Results	Reporting Limit	Units	Tech	Analysis Date
***4-Bromofluorobenzene	EPA 8260	100	70-130	% R	MQS	08/31/2009
Preparation	EPA 5030B	1.0		CF	MQS	08/31/2009
PAHS BY GCMS	EPA 8270				CMG	09/09/2009
Naphthalene	EPA 8270	<2.0	2.0	ug/L	CMG	09/09/2009
2-Methylnaphthalene	EPA 8270	<2.0	2.0	ug/L	CMG	09/09/2009
Acenaphthylene	EPA 8270	<2.0	2.0	ug/L	CMG	09/09/2009
Acenaphthene	EPA 8270	<2.0	2.0	ug/L	CMG	09/09/2009
Fluorene	EPA 8270	<2.0	2.0	ug/L	CMG	09/09/2009
Phenanthrene	EPA 8270	<2.0	2.0	ug/L	CMG	09/09/2009
Anthracene	EPA 8270	<2.0	2.0	ug/L	CMG	09/09/2009
Fluoranthene	EPA 8270	<2.0	2.0	ug/L	CMG	09/09/2009
Pyrene	EPA 8270	<2.0	2.0	ug/L	CMG	09/09/2009
Benzo [a] Anthracene	EPA 8270	<2.0	2.0	ug/L	CMG	09/09/2009
Chrysene	EPA 8270	<2.0	2.0	ug/L	CMG	09/09/2009
Benzo [b] Fluoranthene	EPA 8270	<2.0	2.0	ug/L	CMG	09/09/2009
Benzo [k] Fluoranthene	EPA 8270	<2.0	2.0	ug/L	CMG	09/09/2009
Benzo [a] Pyrene	EPA 8270	<2.0	2.0	ug/L	CMG	09/09/2009
Indeno [1,2,3-cd] Pyrene	EPA 8270	<2.0	2.0	ug/L	CMG	09/09/2009
Dibenzo [a,h] Anthracene	EPA 8270	<2.0	2.0	ug/L	CMG	09/09/2009
Benzo [g,h,i] Perylene	EPA 8270	<2.0	2.0	ug/L	CMG	09/09/2009
Surrogates:	EPA 8270					
***Nitrobenzene-D5	EPA 8270	59.4	30-130	% R	CMG	09/09/2009
***2-Fluorobiphenyl	EPA 8270	63.4	30-130	% R	CMG	09/09/2009
***P-Terphenyl-D14	EPA 8270	69.6	30-130	% R	CMG	09/09/2009
Extraction	EPA 3510C	1.0		DF	KEF	09/01/2009
TOTAL PETROLEUM HYDROCARBON	Mod. EPA 8100				RJD	09/01/2009
Hydrocarbon Content		330	200	ug/L	RJD	09/01/2009
Surrogate:						
***p-Terphenyl		73.2	40-130	% R	RJD	09/01/2009
Extraction	EPA 3510C	1.0		DF	NOG	08/28/2009
METALS						
Arsenic	EPA 6010B	<0.010	0.010	mg/L	LLZ	08/28/2009
Antimony	EPA 6010B	<0.025	0.025	mg/L	LLZ	08/28/2009
Cadmium	EPA 6010B	<0.0050	0.0050	mg/L	LLZ	08/28/2009
Chromium	EPA 6010B	<0.0050	0.0050	mg/L	LLZ	08/28/2009



ANALYTICAL REPORT

GZA GeoEnvironmental, Inc.
 530 Broadway
 Providence, RI 02909

Meg Kilpatrick

Project Name.: **Former Tidewater Facility**
 Project No.: **03.0043654.00**

Date Received: **08/27/2009**
 Date Reported: **09/10/2009**
 Work Order No.: **0908-00130**

Sample ID: **GH-8 S-3**
 Sample Date: **08/26/2009**

Sample No.: **011**

Test Performed	Method	Results	Reporting Limit	Units	Tech	Analysis Date
Copper	EPA 6010B	0.015	0.015	mg/L	LLZ	08/28/2009
Lead	EPA 6010B	0.029	0.010	mg/L	LLZ	08/28/2009
Nickel	EPA 6010B	<0.010	0.010	mg/L	LLZ	08/28/2009
Selenium	EPA 6010B	<0.025	0.025	mg/L	LLZ	08/28/2009
Silver	EPA 6010B	<0.0050	0.0050	mg/L	LLZ	08/28/2009
Iron	EPA 6010B	0.30	0.025	mg/L	LLZ	08/28/2009
Manganese	EPA 6010B	0.17	0.0050	mg/L	LLZ	08/28/2009
Zinc	EPA 6010B	0.028	0.010	mg/L	LLZ	08/28/2009
Mercury	EPA 7470A	<0.00040	0.00040	mg/L	AJY	08/31/2009
HARDNESS	EPA 200.7	1.4		mg CaCO ₃ /L	LLZ	08/28/2009
Calcium	EPA 200.7	0.36	0.025	mg/L	LLZ	08/28/2009
Magnesium	EPA 200.7	0.12	0.025	mg/L	LLZ	08/28/2009
ANIONS - ION CHROMATOGRAPHY	EPA 300.0				TAJ	08/27/2009
Sulfate	EPA 300.0	0.97	0.60	mg/L	TAJ	08/27/2009
Ferric Iron	HACH	0.30		mg/L	AJY	09/09/2009
SUBCONTRACTED ANALYTES						
Ferrous Iron	SM-3500-FE D	<0.40	0.40	mg/L	XXX	08/26/2009
Total Suspended Solids	SM-2540D	<2.0	2.0	mg/L	XXX	08/27/2009
Total Cyanide	SM-4500CN-C E	0.04	0.01	mg/L	XXX	09/01/2009
Free Cyanide	SM4500-CN,H	<0.01	0.01	mg/L	XXX	08/28/2009



ANALYTICAL REPORT

GZA GeoEnvironmental, Inc.
 530 Broadway
 Providence, RI 02909

Meg Kilpatrick

Project Name.: **Former Tidewater Facility**
 Project No.: **03.0043654.00**

Date Received: **08/27/2009**
 Date Reported: **09/10/2009**
 Work Order No.: **0908-00130**

Sample ID: **GH-8 S-3 Dissolved Metals**
 Sample Date: **08/26/2009**

Sample No.: **012**

Test Performed	Method	Results	Reporting Limit	Units	Tech	Analysis Date
DISSOLVED METALS						
Arsenic	EPA 6010B	<0.010	0.010	mg/L	LLZ	08/28/2009
Antimony	EPA 6010B	<0.025	0.025	mg/L	LLZ	08/28/2009
Cadmium	EPA 6010B	<0.0050	0.0050	mg/L	LLZ	08/28/2009
Chromium	EPA 6010B	<0.0050	0.0050	mg/L	LLZ	08/28/2009
Copper	EPA 6010B	<0.015	0.015	mg/L	LLZ	08/28/2009
Lead	EPA 6010B	0.026	0.010	mg/L	LLZ	08/28/2009
Nickel	EPA 6010B	<0.010	0.010	mg/L	LLZ	08/28/2009
Selenium	EPA 6010B	<0.025	0.025	mg/L	LLZ	08/28/2009
Silver	EPA 6010B	<0.0050	0.0050	mg/L	LLZ	08/28/2009
Iron	EPA 6010B	0.057	0.025	mg/L	LLZ	08/28/2009
Manganese	EPA 6010B	0.17	0.0050	mg/L	LLZ	08/28/2009
Zinc	EPA 6010B	0.031	0.010	mg/L	LLZ	08/28/2009
Mercury	EPA 7470A	<0.00040	0.00040	mg/L	AJY	08/31/2009

GZA GEOENVIRONMENTAL, INC.
ENVIRONMENTAL CHEMISTRY LABORATORY
106 SOUTH ST, HOPKINTON, MA 01748
MASSACHUSETTS LABORATORY I.D. NO. MA092

EPA METHOD 300.0 ANALYSIS
Anions by Ion Chromatography

QUALITY CONTROL - Aqueous

DATE PREPARED: 8/27/09

QC Sample	Method Blank	LCS	LCSD	LCS/LCSD Difference
Units	mg/L	% Recovery	% Recovery	RPD
Acceptance Limits	Results	90-110 %	90-110%	20%
Analyte				
Fluoride	NA	NA	NA	NA
Chloride	NA	NA	NA	NA
Nitrite	NA	NA	NA	NA
Nitrate	NA	NA	NA	NA
Phosphate	NA	NA	NA	NA
Sulfate	<0.600	101	97.4	3.71

RPD = Relative Percent Difference

GZA GEOENVIRONMENTAL, INC.
 ENVIRONMENTAL CHEMISTRY LABORATORY
 106 SOUTH ST, HOPKINTON, MA 01748
 MASSACHUSETTS LABORATORY I.D. NO. MA092

EPA METHOD 6010B ANALYSIS
Metals by ICP

QUALITY CONTROL - AQUEOUS

DATE PREPARED: 8/28/2009

QC Sample Units Acceptance Limits	Method Blank mg/L Results	Lab Control Sample % Recovery 80-120	LC Duplicate % Recovery 80-10	LC/LCD Diff. RPD 20%
Analyte				
Silver (Ag)	<0.0050	95.7	94.9	0.83
Aluminum (Al)	NA	NA	NA	NA
Arsenic (As)	<0.010	100	100	0.04
Boron (B)	NA	NA	NA	NA
Barium (Ba)	NA	NA	NA	NA
Beryllium (Be)	NA	NA	NA	NA
Calcium (Ca)	NA	NA	NA	NA
Cadmium (Cd)	<0.0050	99.1	98.4	0.67
Cobalt (Co)	NA	NA	NA	NA
Chromium (Cr)	<0.0050	98.6	98.2	0.39
Copper (Cu)	<0.015	108	107	1.04
Iron (Fe)	<0.025	103	103	0.07
Magnesium (Mg)	NA	NA	NA	NA
Manganese (Mn)	<0.0050	101	100	0.79
Molybdenum (Mo)	NA	NA	NA	NA
Nickel (Ni)	<0.010	101	101	0.52
Lead (Pb)	<0.010	99.3	99.1	0.17
Antimony (Sb)	<0.025	103	104	0.20
Selenium (Se)	<0.025	104	104	0.14
Strontium (Sr)	NA	NA	NA	NA
Titanium (Ti)	NA	NA	NA	NA
Thallium (Tl)	NA	NA	NA	NA
Vanadium (V)	NA	NA	NA	NA
Zinc (Zn)	<0.010	105	102	2.82
Zirconium (Zr)	NA	NA	NA	NA
Tin (Sn)	NA	NA	NA	NA

Matrix Spike / Duplicate Spike performed as per method and reported if assigned on Chain of Custody.

GZA GEOENVIRONMENTAL, INC.
ENVIRONMENTAL CHEMISTRY LABORATORY
106 SOUTH ST, HOPKINTON, MA 01748
MASSACHUSETTS LABORATORY I.D. NO. MA092

EPA METHOD 7470A ANALYSIS
Mercury by Cold Vapor Atomic Absorption

QUALITY CONTROL - AQUEOUS

Date Prepared : 08/28/09

QC Sample	Method Blank	Lab Control Sample	Lab Control Sample Duplicate	LC/LCD Difference
Units	mg/L	% Recovery	% Recovery	RPD
Acceptance Limits	Results	80-120	80-120	20%
Analyte				
Mercury (Hg)	<0.00040	93.6	83.3	11.6

RPD = Relative Percent Difference

GZA GEOENVIRONMENTAL, INC.
ENVIRONMENTAL CHEMISTRY LABORATORY
106 SOUTH ST, HOPKINTON, MA 01748
MASSACHUSETTS LABORATORY I.D. NO. MA092

EPA METHOD 200.7 ANALYSIS
Metals by ICP

QUALITY CONTROL - WASTEWATER

DATE PREPARED: 8/28/2009

QC Sample	Method Blank	Lab Control Sample
Units	mg/L	% Recovery
Acceptance Limits	Results	85-115
Analyte		
Silver (Ag)	NA	NA
Aluminum (Al)	NA	NA
Arsenic (As)	NA	NA
Boron (B)	NA	NA
Barium (Ba)	NA	NA
Beryllium (Be)	NA	NA
Calcium (Ca)	<0.025	100
Cadmium (Cd)	NA	NA
Cobalt (Co)	NA	NA
Chromium (Cr)	NA	NA
Copper (Cu)	NA	NA
Iron (Fe)	NA	NA
Magnesium (Mg)	<0.025	102
Manganese (Mn)	NA	NA
Molybdenum (Mo)	NA	NA
Nickel (Ni)	NA	NA
Lead (Pb)	NA	NA
Antimony (Sb)	NA	NA
Selenium (Se)	NA	NA
Strontium (Sr)	NA	NA
Titanium (Ti)	NA	NA
Thallium (Tl)	NA	NA
Vanadium (V)	NA	NA
Zinc (Zn)	NA	NA
Zirconium (Zr)	NA	NA
Tin (Sn)	NA	NA

Matrix Spike / Duplicate Spike performed as per method and reported if assigned on Chain of Custody.

EPA Method 8260 / 524.2 Aqueous Method Blank (MB) and Laboratory Control Sample/Duplicate (LCS/LCSD) Data

Method Blank			Laboratory Control Sample				Laboratory Control Sample Duplicate						
Date Analyzed:	8/31/2009		Date Analyzed:	8/31/2009		8/31/2009		8/31/2009		8/31/2009		8/31/2009	
Volatile Organics	Conc. ug/L	Acceptance Limit	Spike Concentration = 20ug/L	% Recovery	Acceptance Limits	Verdict	% Recovery	Acceptance Limits	Verdict	RPD	Limit	Verdict	
dichlorodifluoromethane	< 1.0	< 1.0	dichlorodifluoromethane	104	70-130	ok	101	70-130	ok	2.26	<25	ok	
chloromethane	< 1.0	< 1.0	chloromethane	95.5	70-130	ok	93.7	70-130	ok	1.84	<25	ok	
vinyl chloride	< 0.5	< 0.5	vinyl chloride	105	80-120	ok	103	70-130	ok	1.81	<25	ok	
bromomethane	< 1.0	< 1.0	bromomethane	96.4	70-130	ok	93.9	70-130	ok	2.70	<25	ok	
chloroethane	< 0.5	< 0.5	chloroethane	102	70-130	ok	98.6	70-130	ok	3.30	<25	ok	
trichlorofluoromethane	< 1.0	< 1.0	trichlorofluoromethane	97.0	70-130	ok	92.3	70-130	ok	4.91	<25	ok	
diethyl ether	< 2.5	< 2.5	diethyl ether	102	70-130	ok	99.3	70-130	ok	2.21	<25	ok	
acetone	< 13	< 13	acetone	106	70-130	ok	103	70-130	ok	3.14	<25	ok	
1,1-dichloroethane	< 0.5	< 0.5	1,1-dichloroethane	95.7	80-120	ok	95.2	70-130	ok	0.49	<25	ok	
FREON-113	< 1.0	< 1.0	FREON-113	108	70-130	ok	108	70-130	ok	0.13	<25	ok	
iodomethane	< 0.5	< 0.5	iodomethane	100	70-130	ok	98.4	70-130	ok	1.95	<25	ok	
carbon disulfide	< 5.0	< 5.0	carbon disulfide	111	70-130	ok	105	70-130	ok	4.69	<25	ok	
dichloromethane	< 1.0	< 1.0	dichloromethane	94.8	70-130	ok	93.7	70-130	ok	1.17	<25	ok	
tert-butyl alcohol (TBA)	< 13	< 13	tert-butyl alcohol (TBA)	109	70-130	ok	104	70-130	ok	4.85	<25	ok	
acrylonitrile	< 0.5	< 0.5	acrylonitrile	108	70-130	ok	103	70-130	ok	4.65	<25	ok	
methyl-tert-butyl-ether	< 0.5	< 0.5	methyl-tert-butyl-ether	106	70-130	ok	104	70-130	ok	1.42	<25	ok	
trans-1,2-dichloroethane	< 0.5	< 0.5	trans-1,2-dichloroethane	111	70-130	ok	108	70-130	ok	3.09	<25	ok	
1,1-dichloroethane	< 0.5	< 0.5	1,1-dichloroethane	100	70-130	ok	98.1	70-130	ok	1.97	<25	ok	
di-isopropyl ether (DIPE)	< 1.0	< 1.0	di-isopropyl ether (DIPE)	101	70-130	ok	99.2	70-130	ok	1.33	<25	ok	
ethyl tert-butyl ether (ETBE)	< 1.0	< 1.0	ethyl tert-butyl ether (ETBE)	104	70-130	ok	102	70-130	ok	2.72	<25	ok	
vinyl acetate	< 13	< 13	vinyl acetate	103	70-130	ok	102	70-130	ok	1.38	<25	ok	
2-butanone	< 13	< 13	2-butanone	112	70-130	ok	108	70-130	ok	3.73	<25	ok	
2,2-dichloropropane	< 0.5	< 0.5	2,2-dichloropropane	109	70-130	ok	105	70-130	ok	4.35	<25	ok	
cis-1,2-dichloroethane	< 0.5	< 0.5	cis-1,2-dichloroethane	96.5	70-130	ok	96.4	70-130	ok	0.06	<25	ok	
chloroform	< 0.5	< 0.5	chloroform	93.3	80-120	ok	92.7	70-130	ok	0.63	<25	ok	
bromochloromethane	< 0.5	< 0.5	bromochloromethane	104	70-130	ok	103	70-130	ok	0.88	<25	ok	
tetrahydrofuran	< 5.0	< 5.0	tetrahydrofuran	103	70-130	ok	99.2	70-130	ok	4.21	<25	ok	
1,1,1-trichloroethane	< 0.5	< 0.5	1,1,1-trichloroethane	95.0	70-130	ok	91.8	70-130	ok	4.44	<25	ok	
1,1-dichloropropene	< 0.5	< 0.5	1,1-dichloropropene	99.5	70-130	ok	97.4	70-130	ok	2.22	<25	ok	
carbon tetrachloride	< 0.5	< 0.5	carbon tetrachloride	97.4	70-130	ok	94.8	70-130	ok	2.67	<25	ok	
1,2-dichloroethane	< 0.5	< 0.5	1,2-dichloroethane	96.0	70-130	ok	92.9	70-130	ok	3.25	<25	ok	
benzene	< 0.5	< 0.5	benzene	104	70-130	ok	101	70-130	ok	2.79	<25	ok	
tert-amyl methyl ether (TAME)	< 1.0	< 1.0	tert-amyl methyl ether (TAME)	106	70-130	ok	105	70-130	ok	1.03	<25	ok	
trichloroethane	< 0.5	< 0.5	trichloroethane	104	70-130	ok	101	70-130	ok	3.02	<25	ok	
1,2-dichloropropane	< 0.5	< 0.5	1,2-dichloropropane	101	80-120	ok	100	70-130	ok	0.64	<25	ok	
bromodichloromethane	< 0.5	< 0.5	bromodichloromethane	95.1	70-130	ok	92.1	70-130	ok	3.17	<25	ok	
1,4-Dioxane	< 50	< 50	1,4-Dioxane	101	70-130	ok	105	70-130	ok	3.62	<25	ok	
dibromomethane	< 0.5	< 0.5	dibromomethane	105	70-130	ok	103	70-130	ok	1.36	<25	ok	
4-methyl-2-pentanone	< 13	< 13	4-methyl-2-pentanone	99.9	70-130	ok	98.6	70-130	ok	1.28	<25	ok	
cis-1,3-dichloropropene	< 0.5	< 0.5	cis-1,3-dichloropropene	100	70-130	ok	98.9	70-130	ok	1.53	<25	ok	
toluene	< 0.5	< 0.5	toluene	100	80-120	ok	99.4	70-130	ok	0.70	<25	ok	
trans-1,3-dichloropropene	< 1.0	< 1.0	trans-1,3-dichloropropene	99.7	70-130	ok	97.2	70-130	ok	2.61	<25	ok	
1,1,2-trichloroethane	< 0.5	< 0.5	1,1,2-trichloroethane	97.1	70-130	ok	93.6	70-130	ok	3.61	<25	ok	
2-hexanone	< 13	< 13	2-hexanone	98.5	70-130	ok	93.1	70-130	ok	5.60	<25	ok	
1,3-dichloropropane	< 0.5	< 0.5	1,3-dichloropropane	98.5	70-130	ok	92.9	70-130	ok	5.85	<25	ok	
tetrachloroethane	< 0.5	< 0.5	tetrachloroethane	104	70-130	ok	98.2	70-130	ok	5.53	<25	ok	
dibromochloromethane	< 0.5	< 0.5	dibromochloromethane	101	70-130	ok	94.2	70-130	ok	7.33	<25	ok	
1,2-dibromoethane (EDB)	< 1.0	< 1.0	1,2-dibromoethane (EDB)	103	70-130	ok	97.2	70-130	ok	6.15	<25	ok	
chlorobenzene	< 0.5	< 0.5	chlorobenzene	99.6	70-130	ok	93.6	70-130	ok	6.23	<25	ok	
1,1,1,2-tetrachloroethane	< 0.5	< 0.5	1,1,1,2-tetrachloroethane	101	70-130	ok	95.4	70-130	ok	5.58	<25	ok	
ethylbenzene	< 0.5	< 0.5	ethylbenzene	100	80-120	ok	94.8	70-130	ok	5.72	<25	ok	
1,1,2,2-tetrachloroethane	< 0.5	< 0.5	1,1,2,2-tetrachloroethane	103	70-130	ok	99.4	70-130	ok	4.00	<25	ok	
m&p-xylene	< 1.0	< 1.0	m&p-xylene	98.4	70-130	ok	92.4	70-130	ok	6.36	<25	ok	
o-xylene	< 0.5	< 0.5	o-xylene	96.6	70-130	ok	94.0	70-130	ok	2.71	<25	ok	
styrene	< 0.5	< 0.5	styrene	99.5	70-130	ok	97.7	70-130	ok	1.77	<25	ok	
bromoform	< 1.0	< 1.0	bromoform	104	70-130	ok	102	70-130	ok	1.75	<25	ok	
isopropylbenzene	< 0.5	< 0.5	isopropylbenzene	117	70-130	ok	113	70-130	ok	3.02	<25	ok	
1,2,3-trichloropropane	< 0.5	< 0.5	1,2,3-trichloropropane	102	70-130	ok	97.2	70-130	ok	4.45	<25	ok	
bromobenzene	< 0.5	< 0.5	bromobenzene	105	70-130	ok	102	70-130	ok	2.38	<25	ok	
n-propylbenzene	< 0.5	< 0.5	n-propylbenzene	104	70-130	ok	101	70-130	ok	2.73	<25	ok	
2-chlorotoluene	< 0.5	< 0.5	2-chlorotoluene	97.9	70-130	ok	94.8	70-130	ok	3.18	<25	ok	
1,3,5-trimethylbenzene	< 0.5	< 0.5	1,3,5-trimethylbenzene	101	70-130	ok	98.9	70-130	ok	2.58	<25	ok	
trans-1,4-dichloro-2-butene	< 1.0	< 1.0	trans-1,4-dichloro-2-butene	101	70-130	ok	97.5	70-130	ok	3.62	<25	ok	
4-chlorotoluene	< 0.5	< 0.5	4-chlorotoluene	98.4	70-130	ok	97.0	70-130	ok	1.44	<25	ok	
tert-butyl-benzene	< 0.5	< 0.5	tert-butyl-benzene	98.6	70-130	ok	98.0	70-130	ok	0.63	<25	ok	
1,2,4-trimethylbenzene	< 0.5	< 0.5	1,2,4-trimethylbenzene	101	70-130	ok	98.1	70-130	ok	3.30	<25	ok	
sec-butyl-benzene	< 0.5	< 0.5	sec-butyl-benzene	98.8	70-130	ok	97.0	70-130	ok	1.85	<25	ok	
p-isopropyltoluene	< 0.5	< 0.5	p-isopropyltoluene	103	70-130	ok	100	70-130	ok	2.31	<25	ok	
1,3-dichlorobenzene	< 0.5	< 0.5	1,3-dichlorobenzene	103	70-130	ok	101	70-130	ok	2.27	<25	ok	
1,4-dichlorobenzene	< 0.5	< 0.5	1,4-dichlorobenzene	103	70-130	ok	102	70-130	ok	1.31	<25	ok	
n-butylbenzene	< 0.5	< 0.5	n-butylbenzene	101	70-130	ok	98.2	70-130	ok	2.94	<25	ok	
1,2-dichlorobenzene	< 0.5	< 0.5	1,2-dichlorobenzene	104	70-130	ok	102	70-130	ok	2.44	<25	ok	
1,2-dibromo-3-chloropropane	< 2.5	< 2.5	1,2-dibromo-3-chloropropane	112	70-130	ok	105	70-130	ok	6.71	<25	ok	
1,3,5-trichlorobenzene	< 0.5	< 0.5	1,3,5-trichlorobenzene	110	70-130	ok	107	70-130	ok	1.90	<25	ok	
1,2,4-trichlorobenzene	< 0.5	< 0.5	1,2,4-trichlorobenzene	112	70-130	ok	110	70-130	ok	1.46	<25	ok	
hexachlorobutadiene	< 0.5	< 0.5	hexachlorobutadiene	107	70-130	ok	103	70-130	ok	3.12	<25	ok	
naphthalene	< 1.0	< 1.0	naphthalene	102	70-130	ok	104	70-130	ok	1.19	<25	ok	
1,2,3-trichlorobenzene	< 0.5	< 0.5	1,2,3-trichlorobenzene	110	70-130	ok	107	70-130	ok	2.81	<25	ok	

Surrogates:		Recovery (%)	Acceptance Limits	Surrogates:		Recovery (%)	Acceptance Limits	Verdict	Surrogates:		Recovery (%)	Acceptance Limits	Verdict	RPD	Acceptance Limits	Verdict
DIBROMOFUOROMETHANE		99.3	70-130	DIBROMOFUOROMETHANE		95.5	70-130	ok	DIBROMOFUOROMETHANE		98.6	70-130	ok	3.20	<25	ok
1,2-DICHLOROETHANE-D4		104	70-130	1,2-DICHLOROETHANE-D4		101	70-130	ok	1,2-DICHLOROETHANE-D4		98.4	70-130	ok	2.18	<25	ok
TOLUENE-D8		98.5	70-130	TOLUENE-D8		98.6	70-130	ok	TOLUENE-D8		98.0	70-130	ok	0.14	<25	ok
4-BROMOFUOROBENZENE		95.6	70-130	4-BROMOFUOROBENZENE		98.6	70-130	ok	4-BROMOFUOROBENZENE		101	70-130	ok	2.05	<25	ok
1,2-DICHLOROENZENE-D4		93.6	70-130	1,2-DICHLOROENZENE-D4		99.8	70-130	ok	1,2-DICHLOROENZENE-D4		102	70-130	ok	1.75	<25	ok

EPA Method 8270/825 Aqueous Method Blank (MB) and Laboratory Control Sample (LCS) Data

Method Blank

Date Extracted: 09/01/09
Date Analyzed: 09/08/09
File Name: M2380

Semi-Volatile Organics	Result	Reporting Limit (ug/L)
naphthalene	ND	2.0
2-methylnaphthalene	ND	2.0
acenaphthylene	ND	2.0
acenaphthene	ND	2.0
fluorene	ND	2.0
phenanthrene	ND	2.0
anthracene	ND	2.0
fluoranthene	ND	2.0
pyrene	ND	2.0
benz [a] anthracene	ND	2.0
chrysene	ND	2.0
benzo [b] fluoranthene	ND	2.0
benzo [k] fluoranthene	ND	2.0
benzo [a] pyrene	ND	2.0
indeno [1,2,3-cd] pyrene	ND	2.0
dibenz [a,h] anthracene	ND	2.0
benzo [ghi] perylene	ND	2.0

Surrogates:	Recovery (%)	Acceptance Limits
NITROBENZENE-D5	53.6	30-130
2-FLUOROBIPHENYL	56.7	30-130
p-TERPHENYL-D14	58.3	30-130

EPA Method 8270/625 Aqueous Method Blank (MB) and Laboratory Control Sample (LCS) Data

Laboratory Control Sample

Date Extracted: 09/01/09
 Date Analyzed: 09/08/09
 File Name: M2381

Spike Concentration = 20ug/L	% Recovery	Acceptance Limits	Verdict
naphthalene	51.5	40-140	ok
2-methylnaphthalene	47.0	40-140	ok
acenaphthylene	53.4	40-140	ok
acenaphthene	52.6	40-140	ok
fluorene	58.2	40-140	ok
phenanthrene	57.0	40-140	ok
anthracene	58.0	40-140	ok
fluoranthene	57.9	40-140	ok
pyrene	57.8	40-140	ok
benz [a] anthracene	57.9	40-140	ok
chrysene	55.2	40-140	ok
benzo [b] fluoranthene	55.8	40-140	ok
benzo [k] fluoranthene	60.7	40-140	ok
benzo [a] pyrene	57.8	40-140	ok
indeno [1,2,3-cd] pyrene	55.4	40-140	ok
dibenz [a,h] anthracene	56.2	40-140	ok
benzo [ghi] perylene	56.0	40-140	ok

CAM criteria allows 15% of analytes to exceed criteria.

Surrogates:	Recovery (%)	Acceptance Limits	Verdict
NITROBENZENE-D5	46.8	30-130	ok
2-FLUOROBIPHENYL	50.0	30-130	ok
p-TERPHENYL-D14	51.6	30-130	ok



CERTIFICATE OF ANALYSIS

GZA GeoEnvironmental Labs
Attn: Ms. Michelle Miranda
Engineers and Scientists
106 South Street
Hopkinton, MA 01748

Date Received: 8/26/09
Date Reported: 9/1/09
P.O. #: 8-32761
Work Order #: 0908-15312

DESCRIPTION: GZA FILE NO: 03.0843654.00 TIDEWATER PAWTUCKET, RI

Subject sample(s) has/have been analyzed by our Warwick, R.I. laboratory with the attached results.

Reference: All parameters were analyzed by U.S. EPA approved methodologies.
The specific methodologies are listed in the methods column of the Certificate Of Analysis.

Data qualifiers (if present) are explained in full at the end of a given sample's analytical results.

Certification #: RI-033, MA-RI015, CT-PH-0508, ME-RI015
NH-253700 A & B, USDA S-41844

If you have any questions regarding this work, or if we may be of further assistance, please contact our customer service department.

Approved by:



Data Reporting

enc: Chain of Custody

R.I. Analytical Laboratories, Inc.

CERTIFICATE OF ANALYSIS

GZA GeoEnvironmental Labs

Date Received: 8/26/09

Work Order #: 0908-15312

Approved by: 

Data Reported

Sample # 001

SAMPLE DESCRIPTION: GH-7 S-1

SAMPLE TYPE: GRAB

SAMPLE DATE/TIME: 8/26/2009 @ 08:45

PARAMETER	SAMPLE RESULTS	DET. LIMIT	UNITS	METHOD	DATE ANALYZED	ANALYST
Ferrous Iron	<0.40	0.40	mg/l	SM-3500-FE D	8/26/09	CAA
Total Suspended Solids	2.0	2.0	mg/l	SM-2540D	8/27/09	JJP
Total Cyanide	0.06	0.01	mg/l	SM-4500CN-C E	9/1/09	EC
Free Cyanide	<0.01	0.01	mg/l	SM4500-CN,H	8/28/09	ML

Sample # 002

SAMPLE DESCRIPTION: GH-7 S-2

SAMPLE TYPE: GRAB

SAMPLE DATE/TIME: 8/26/2009 @ 09:05

PARAMETER	SAMPLE RESULTS	DET. LIMIT	UNITS	METHOD	DATE ANALYZED	ANALYST
Ferrous Iron	<0.40	0.40	mg/l	SM-3500-FE D	8/26/09	CAA
Total Suspended Solids	<2.0	2.0	mg/l	SM-2540D	8/27/09	JJP
Total Cyanide	0.04	0.01	mg/l	SM-4500CN-C E	9/1/09	EC
Free Cyanide	<0.01	0.01	mg/l	SM4500-CN,H	8/28/09	ML

Sample # 003

SAMPLE DESCRIPTION: GH-7 S-3

SAMPLE TYPE: GRAB

SAMPLE DATE/TIME: 8/26/2009 @ 09:20

PARAMETER	SAMPLE RESULTS	DET. LIMIT	UNITS	METHOD	DATE ANALYZED	ANALYST
Ferrous Iron	<0.40	0.40	mg/l	SM-3500-FE D	8/26/09	CAA
Total Suspended Solids	<2.0	2.0	mg/l	SM-2540D	8/27/09	JJP
Total Cyanide	0.06	0.01	mg/l	SM-4500CN-C E	9/1/09	EC
Free Cyanide	<0.01	0.01	mg/l	SM4500-CN,H	8/28/09	ML

Sample # 004

SAMPLE DESCRIPTION: GH-8 S-1

SAMPLE TYPE: GRAB

SAMPLE DATE/TIME: 8/26/2009 @ 11:25

PARAMETER	SAMPLE RESULTS	DET. LIMIT	UNITS	METHOD	DATE ANALYZED	ANALYST
Ferrous Iron	<0.40	0.40	mg/l	SM-3500-FE D	8/26/09	CAA
Total Suspended Solids	<2.0	2.0	mg/l	SM-2540D	8/27/09	JJP
Total Cyanide	<0.01	0.01	mg/l	SM-4500CN-C E	9/1/09	EC
Free Cyanide	<0.01	0.01	mg/l	SM4500-CN,H	8/28/09	ML

R.I. Analytical Laboratories, Inc.
CERTIFICATE OF ANALYSIS

GZA GeoEnvironmental Labs
 Date Received: 8/26/09
 Work Order #: 0908-15312

Approved by: _____

Data Reporting

Sample # 005

SAMPLE DESCRIPTION: GH-8 S-2

SAMPLE TYPE: GRAB

SAMPLE DATE/TIME: 8/26/2009 @ 11:35

PARAMETER	SAMPLE RESULTS	DET. LIMIT	UNITS	METHOD	DATE ANALYZED	ANALYST
Ferrous Iron	<0.40	0.40	mg/l	SM-3500-FE D	8/26/09	CAA
Total Suspended Solids	<2.0	2.0	mg/l	SM-2540D	8/27/09	JJP
Total Cyanide	0.04	0.01	mg/l	SM-4500CN-C E	9/1/09	EC
Free Cyanide	<0.01	0.01	mg/l	SM4500-CN,H	8/28/09	ML

Sample # 006

SAMPLE DESCRIPTION: GH-8 S-3

SAMPLE TYPE: GRAB

SAMPLE DATE/TIME: 8/26/2009 @ 11:45

PARAMETER	SAMPLE RESULTS	DET. LIMIT	UNITS	METHOD	DATE ANALYZED	ANALYST
Ferrous Iron	<0.40	0.40	mg/l	SM-3500-FE D	8/26/09	CAA
Total Suspended Solids	<2.0	2.0	mg/l	SM-2540D	8/27/09	JJP
Total Cyanide	0.04	0.01	mg/l	SM-4500CN-C E	9/1/09	ML
Free Cyanide	<0.01	0.01	mg/l	SM4500-CN,H	8/28/09	ML



QA/QC Report

Client: GZA GeoEnvironmental Labs
WO #: 0908-15312
Date: 9/1/09

Description: GZA FILE NO: 03.0843654.00 TIDEWATER PAWTUCKET, RI

-Method Blanks Results-

Parameter	Units	Results	Date Analyzed
Ferrous Iron	mg/l	<0.40	8/26/2009
Total Suspended Solids	mg/l	<2.0	8/27/2009
Total Suspended Solids	mg/l	<2.0	8/27/2009
Total Cyanide	mg/l	<0.01	9/1/2009

-LCS/LCS Duplicate Data Results-

Parameter	Spike Conc	LCS Conc	LCS % Rec	LCS Dup Conc	LCS DUP % Rec	% RPD
Ferrous Iron	3.0	3.08	103			0
Total Cyanide	0.10	0.107	107	0.102	102	5

APPENDIX E

PERMIT APPLICATION FEE

202717



KeyBank National Association
Salt Lake City, Utah 84115
1-800-KEY2YOU

GZA GeoEnvironmental, Inc.
ONE EDGEWATER DR.
NORWOOD, MA 02062

31-300-1243

CHECK DATE October 26, 2009

PAY Four Hundred and 00/100 Dollars

TO Treasurer State Of Rhode Island

AMOUNT \$400.00

NOT VALID IN EXCESS OF \$10,000 UNLESS COUNTERSIGNED

David Brew

AUTHORIZED SIGNATURE

43654 NOI

⑈ 202717⑈ ⑆ 124303007⑆ 440991900109⑈

Security features. Details on back.